

Application Note: Structural Elucidation of Isoindolinone-Based MDM2 Inhibitors via Molecular Docking

Author: BenchChem Technical Support Team. **Date:** May 2026

Compound of Interest

Compound Name:	Methyl 1-oxo-2,3-dihydro-1H-isoindole-5-carboxylate
CAS No.:	926307-72-4
Cat. No.:	B1429174

[Get Quote](#)

Abstract & Introduction

The isoindolinone (isoindolin-1-one) scaffold is recognized as a "privileged structure" in medicinal chemistry due to its ability to mimic the spatial orientation of amino acid residues in protein-protein interactions (PPIs). Specifically, isoindolinone derivatives have gained prominence as antagonists of the Murine Double Minute 2 (MDM2) oncoprotein, functioning by mimicking the conserved tryptophan (Trp23) residue of the p53 tumor suppressor protein.[1]

This application note details a rigorous molecular docking protocol to predict the binding affinity and orientation of isoindolinone derivatives within the hydrophobic cleft of MDM2. Unlike standard enzyme-inhibitor docking, PPI inhibition requires precise handling of hydrophobic desolvation and induced-fit effects. This guide emphasizes the critical role of ligand stereochemistry and validation via root-mean-square deviation (RMSD) analysis.

Computational Setup & Ligand Chemistry

The Isoindolinone Scaffold Challenge

The core challenge in docking isoindolinones is the chirality at the C3 position. Synthetic routes often yield racemic mixtures, but biological activity is frequently stereospecific.

- **Chirality:** The C3-substituted isoindolinone possesses a chiral center. You must generate and dock both R- and S- enantiomers separately.
- **Tautomerism:** While the lactam form is dominant, potential tautomeric shifts (lactam-lactim) must be evaluated if the docking software does not automatically penalize high-energy tautomers.

Ligand Preparation Protocol

Objective: Generate energy-minimized 3D conformers with correct ionization states.

- **Structure Generation:** Convert 2D SMILES of the isoindolinone derivatives into 3D structures.
- **Stereoisomer Generation:** For every derivative with an undefined center at C3, generate both enantiomers.
- **Protonation:** Calculate protonation states at physiological pH (7.4 ± 0.5). Isoindolinone nitrogens are typically neutral amides, but pendant groups (e.g., amines on side chains) may be protonated.
- **Minimization:** Apply the OPLS3e or MMFF94 force field to minimize internal strain.

Target Selection & Preparation

Target: MDM2 (E3 ubiquitin-protein ligase). PDB Selection: 1YCR (Crystal structure of MDM2 bound to a p53 transactivation domain peptide) or 4HG7 (MDM2 with a small molecule inhibitor).

Protein Pre-processing

Raw PDB files contain crystallographic artifacts that must be corrected.

- Strip Waters: Remove all water molecules. The MDM2 binding cleft is highly hydrophobic; explicit waters often interfere with the placement of the isoindolinone phenyl groups.
- Completeness Check: Repair missing side chains and loops using a homology modeling tool (e.g., Prime or Modeller) if residues within 5Å of the active site are incomplete.
- Hydrogen Bond Network: Optimize H-bond assignment (flip Asn/Gln/His residues) to maximize internal stability.

Experimental Protocol: Step-by-Step Docking

This protocol assumes the use of a Genetic Algorithm (GA)-based docker (e.g., AutoDock Vina, GOLD, or Glide), which is standard for handling the conformational flexibility of the ligand.

Workflow Visualization

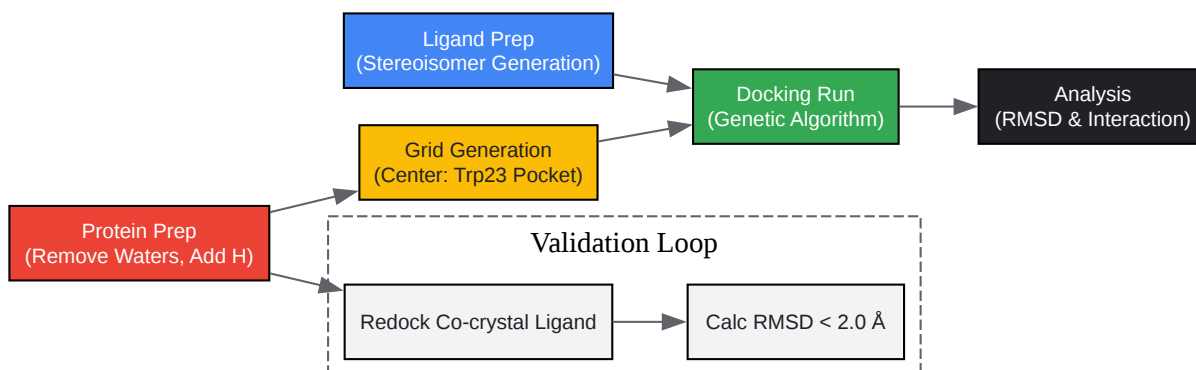

[Click to download full resolution via product page](#)

Figure 1: The molecular docking workflow emphasizing the parallel preparation of ligand and protein, followed by grid definition and the critical validation loop.

Grid Generation

The MDM2 binding site is defined by the p53 peptide binding groove.

- Center: Define the grid box center using the coordinates of the co-crystallized p53 peptide (specifically the Trp23 residue) or the co-crystallized inhibitor.

- Dimensions:

Å. This is sufficient to cover the three hydrophobic sub-pockets (Phe19, Trp23, Leu26).

Docking Parameters

- Algorithm: Lamarckian Genetic Algorithm (LGA).
- Exhaustiveness: Set to 8 (or equivalent "High" setting) to ensure adequate sampling of the conformational space.
- Poses: Generate 10-20 poses per ligand.
- Scoring Function: Use a function that heavily weights hydrophobic contacts (e.g., ChemScore or Vina), as the MDM2-isoindolinone interaction is driven by entropy (displacement of water) and pi-stacking.

Validation & Quality Assurance (E-E-A-T)

A docking protocol is only as good as its validation. You must perform a "Redocking" experiment before analyzing new compounds.

- Extract: Remove the native ligand (p53 peptide or inhibitor) from the PDB complex.
- Re-dock: Dock this extracted ligand back into the prepared protein using the parameters defined in Section 4.3.
- Calculate RMSD: Superimpose the docked pose onto the original crystallographic pose.
 - Success Criterion: RMSD
Å.
 - If $\text{RMSD} > 2.0 \text{ \AA}$, the protocol is invalid. Re-check protonation states or grid box size.

Data Analysis & Interpretation

Key Interaction Patterns

Isoindolinone inhibitors typically mimic the three key residues of p53:

- Phe19 Mimic: Often a chlorophenyl group on the isoindolinone.
- Trp23 Mimic: The isoindolinone core itself often sits deep in this pocket.
- Leu26 Mimic: A hydrophobic substituent (e.g., isopropyl or phenyl) on the N-terminus.

Interaction Diagram

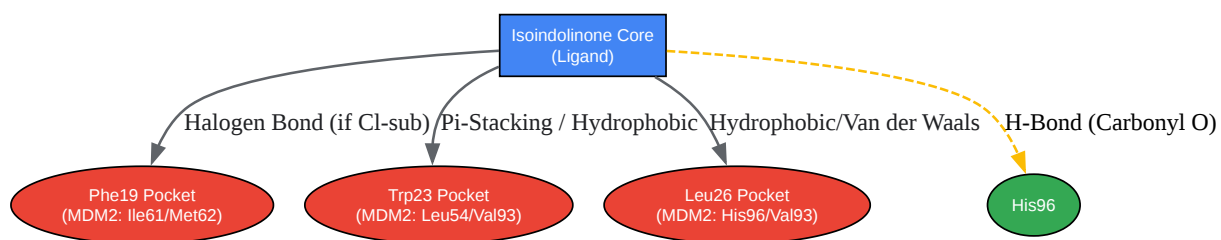

[Click to download full resolution via product page](#)

Figure 2: Predicted interaction map showing how the isoindolinone scaffold recruits specific sub-pockets of the MDM2 protein.

Quantitative Reporting

Summarize your findings in a structured table. Do not rely solely on binding energy; inspect the visual pose.

Ligand ID	Stereochemistry	Binding Energy (kcal/mol)	RMSD (vs. Control)	Key Interactions
Ref (Nutlin-3a)	-	-9.8	0.8 Å	Phe19, Trp23, Leu26 fill
ISO-01 (R)	R	-8.4	N/A	H-bond (Val93), Pi-Pi (His96)
ISO-01 (S)	S	-6.2	N/A	Steric clash with Leu54
ISO-02	Racemic*	-8.9	N/A	Deep Trp23 insertion

*Note: For racemic mixtures, report the score of the best-binding enantiomer.

References

- Hardcastle, I. R., et al. (2005). Isoindolinone-based inhibitors of the MDM2-p53 protein-protein interaction.[2][3][4][5] Bioorganic & Medicinal Chemistry Letters.
- Wang, S., & Zhao, Y. (2014). The Docking Based 3D-QSAR Studies on Isoindolinone Derived Inhibitors of p53-MDM2 Binding. Combinatorial Chemistry & High Throughput Screening.
- Trott, O., & Olson, A. J. (2010). AutoDock Vina: improving the speed and accuracy of docking with a new scoring function, efficient optimization, and multithreading. Journal of Computational Chemistry.
- Gohlke, H., & Klebe, G. (2002). Approaches to the description and prediction of the binding affinity of small-molecule ligands to macromolecular receptors.[3][6][7] Angewandte Chemie International Edition.

Need Custom Synthesis?

BenchChem offers custom synthesis for rare earth carbides and specific isotopic labeling.

Email: info@benchchem.com or [Request Quote Online](#).

Sources

- [1. researchgate.net \[researchgate.net\]](#)
- [2. scispace.com \[scispace.com\]](#)
- [3. ingentaconnect.com \[ingentaconnect.com\]](#)
- [4. research.nu.edu.kz \[research.nu.edu.kz\]](#)
- [5. benthamdirect.com \[benthamdirect.com\]](#)
- [6. Frontiers | Bridging Molecular Docking to Molecular Dynamics in Exploring Ligand-Protein Recognition Process: An Overview \[frontiersin.org\]](#)
- [7. youtube.com \[youtube.com\]](#)
- To cite this document: BenchChem. [Application Note: Structural Elucidation of Isoindolinone-Based MDM2 Inhibitors via Molecular Docking]. BenchChem, [2026]. [Online PDF]. Available at: [<https://www.benchchem.com/product/b1429174/docs#application-note-structural-elucidation-of-isoindolinone-based-mdm2-inhibitors-via-molecular-docking>]

Disclaimer & Data Validity:

The information provided in this document is for Research Use Only (RUO) and is strictly not intended for diagnostic or therapeutic procedures. While BenchChem strives to provide accurate protocols, we make no warranties, express or implied, regarding the fitness of this product for every specific experimental setup.

Technical Support: The protocols provided are for reference purposes. Unsure if this reagent suits your experiment?

Need Industrial/Bulk Grade? [Request Custom Synthesis Quote](#)

BenchChem

Our mission is to be the trusted global source of essential and advanced chemicals, empowering scientists and researchers to drive progress in science and industry.

Contact

Address: 3281 E Guasti Rd
Ontario, CA 91761, United States
Phone: (601) 213-4426
Email: info@benchchem.com

[Contact our Ph.D. Support Team for a compatibility check](#)