

Application Notes & Protocols: A Guide to Developing Kinase Inhibitors with Indazole Scaffolds

Author: BenchChem Technical Support Team. **Date:** May 2026

Compound of Interest

Compound Name:	4,6-Difluoro-1-methyl-1H-indazole-5-carboxylic acid
CAS No.:	1329166-90-6
Cat. No.:	B1428494

[Get Quote](#)

Introduction: The Strategic Importance of the Indazole Scaffold in Kinase Inhibition

Protein kinases are fundamental regulators of cellular signaling, and their dysregulation is a hallmark of numerous diseases, most notably cancer. The development of small molecule inhibitors that target the ATP-binding site of kinases has revolutionized targeted therapy. Within the vast chemical space explored for kinase inhibition, the indazole scaffold has emerged as a "privileged" structure.^{[1][2][3]} Its bicyclic aromatic system is adept at forming key hydrogen bond interactions with the hinge region of the kinase ATP-binding pocket, a critical anchor point for potent inhibition.^{[4][5]}

Many successful FDA-approved drugs, such as Axitinib and Pazopanib, feature the indazole core, underscoring its clinical significance.^{[1][3]} This guide provides a comprehensive overview of the principles and methodologies involved in the discovery and preclinical development of novel indazole-based kinase inhibitors, intended for researchers and drug development

professionals. We will delve into design strategies, provide detailed synthetic and biological testing protocols, and offer insights into data interpretation.

Part 1: Medicinal Chemistry and Design Principles

The success of an indazole-based inhibitor hinges on the strategic decoration of the core scaffold to achieve potency, selectivity, and favorable drug-like properties.

The Indazole Core: An Ideal Hinge Binder

The indazole ring system can exist as two major tautomers, 1H-indazole and 2H-indazole. The nitrogen atoms of the pyrazole ring are crucial for establishing hydrogen bonds with the kinase hinge region. For instance, in Axitinib, the indazole N1-H acts as a hydrogen bond donor, while N2 acts as an acceptor, mimicking the adenine portion of ATP. This bidentate interaction provides a strong affinity for the target kinase.

Structure-Activity Relationship (SAR) Insights

Systematic modification of the indazole scaffold is essential for optimizing inhibitor performance. Key positions for substitution include:

- **C3-Position:** This position often points towards the solvent-exposed region. Attaching larger, flexible groups can enhance interactions with residues outside the immediate ATP pocket, often influencing selectivity.^[6]
- **C5/C6-Positions:** These positions on the benzene ring can be modified to modulate physicochemical properties like solubility and to establish additional contacts within the binding site.
- **N1/N2-Positions:** Alkylation or arylation at these positions can block the hydrogen-bonding capability but can also be used to probe deeper pockets or improve properties like cell permeability. The choice between N1 and N2 substitution can significantly impact the vector of substituents and overall kinase selectivity.^[7]

A hypothetical SAR study for a generic indazole scaffold targeting VEGFR-2 is summarized below. This illustrates how systematic chemical changes can translate into potency improvements.

Compound ID	R1 (C3-Position)	R2 (C5-Position)	VEGFR-2 IC50 (nM)	Scientist's Note
IND-01	Phenyl	-H	850	Baseline compound. Modest activity.
IND-02	2-Methylphenyl	-H	450	Ortho-substitution on the phenyl ring improves potency, likely through enhanced hydrophobic interactions.
IND-03	Phenyl	-CONH2	200	Addition of a hydrogen-bonding group at C5 significantly enhances activity.[7]
IND-04	2-Methylphenyl	-CONH2	25	Combining the optimal C3 and C5 substituents leads to a synergistic improvement in potency.
Axitinib	2-Methyl-3-(2-pyridinylmethyl)phenyl	-SCH3	0.2	The optimized clinical candidate shows picomolar potency due to extensive, optimized interactions.[8]

Part 2: Key Signaling Pathways Targeted by Indazole Inhibitors

Indazole scaffolds have been successfully employed to target multiple kinase families involved in oncogenesis. Two of the most prominent are the VEGFR and c-Met pathways, which are critical for tumor angiogenesis, proliferation, and metastasis.[9][10]

VEGFR Signaling Pathway

Vascular Endothelial Growth Factor Receptors (VEGFRs), particularly VEGFR-2, are key mediators of angiogenesis—the formation of new blood vessels essential for tumor growth.[10][11][12] Indazole inhibitors like Axitinib potently block the ATP-binding site of VEGFR-2, preventing its autophosphorylation and downstream signaling.[11][13][14] This leads to the inhibition of endothelial cell proliferation, migration, and survival.[15][16]

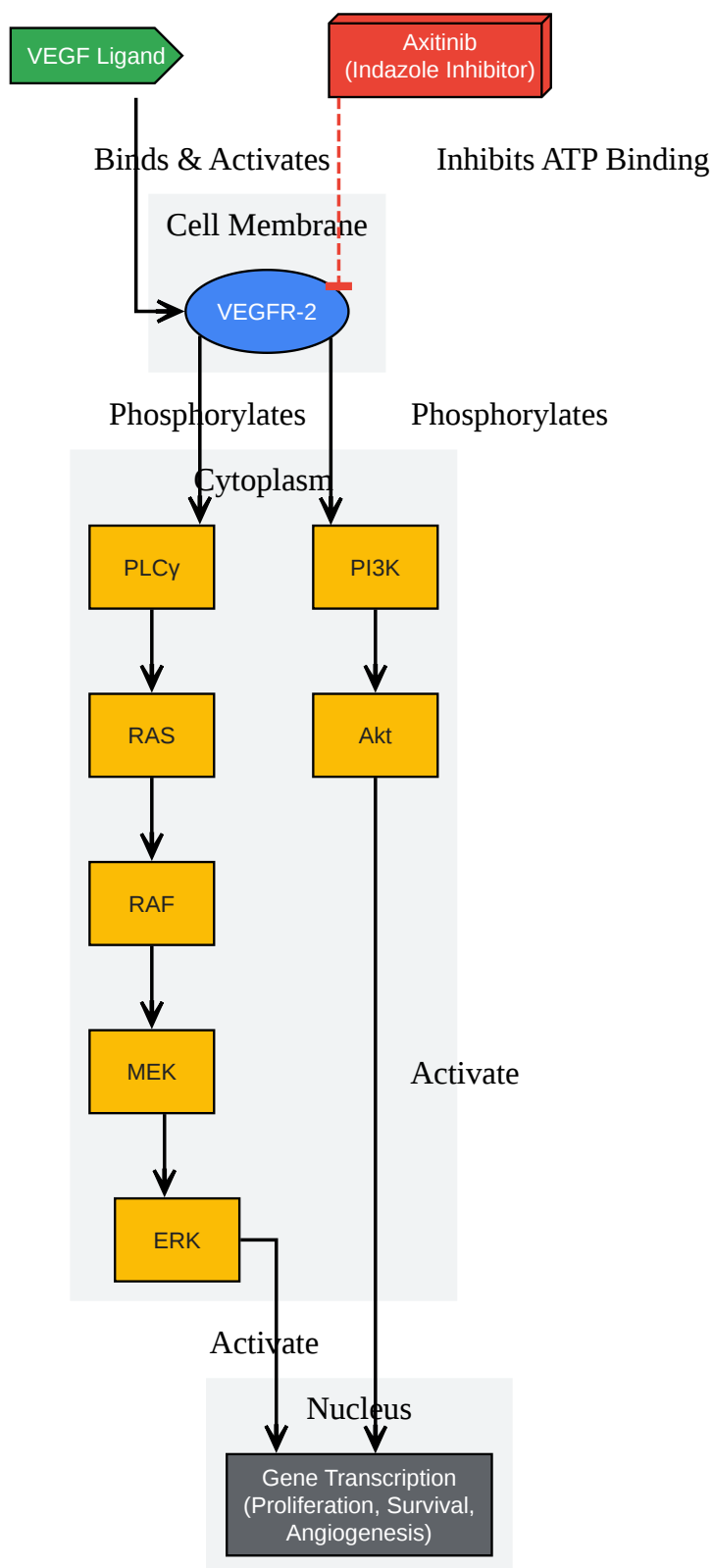

[Click to download full resolution via product page](#)

Caption: Simplified VEGFR-2 signaling pathway and the inhibitory action of an indazole-based drug.

c-Met Signaling Pathway

The c-Met receptor tyrosine kinase and its ligand, Hepatocyte Growth Factor (HGF), play crucial roles in cell proliferation, motility, and invasion.[17][18] Aberrant c-Met signaling is implicated in many cancers, often leading to aggressive tumor growth and metastasis.[9][19] Indazole-based inhibitors can effectively block the c-Met kinase domain, shutting down these oncogenic signals.[17][20]

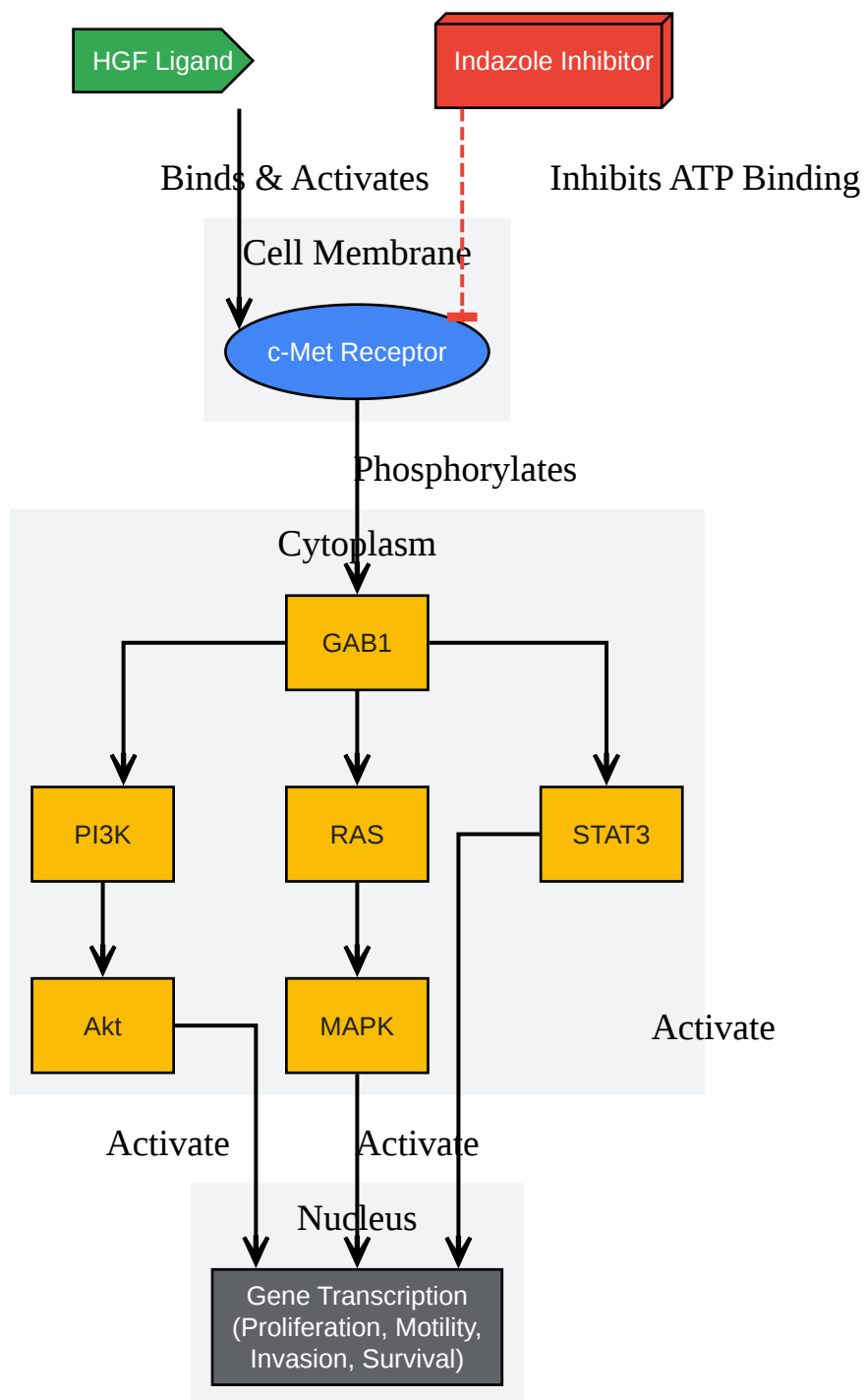

[Click to download full resolution via product page](#)

Caption: Overview of the HGF/c-Met signaling cascade and its therapeutic inhibition.

Part 3: Experimental Protocols

The following protocols provide a framework for the synthesis and evaluation of a novel indazole-based kinase inhibitor.

Protocol: Synthesis of a Representative 3-Aryl-Indazole Scaffold

This protocol describes a common synthetic route involving a Suzuki coupling to install a functionalized aryl group at the C3 position of the indazole core, a key step in synthesizing many inhibitors like Axitinib.

Materials:

- 3-Iodo-1H-indazole
- Arylboronic acid (e.g., 4-(formyl)phenylboronic acid)
- Palladium catalyst (e.g., Pd(PPh₃)₄)
- Base (e.g., Na₂CO₃)
- Solvent (e.g., 1,4-Dioxane/Water mixture)
- Standard laboratory glassware, inert atmosphere setup (N₂ or Ar)

Procedure:

- **Reaction Setup:** To an oven-dried round-bottom flask, add 3-iodo-1H-indazole (1.0 eq), the desired arylboronic acid (1.2 eq), and Na₂CO₃ (2.5 eq).
- **Inert Atmosphere:** Seal the flask with a septum, and purge with nitrogen or argon for 10-15 minutes.
- **Solvent & Catalyst Addition:** Under the inert atmosphere, add the dioxane/water solvent mixture (typically 4:1 v/v). Degas the solution by bubbling N₂ through it for another 10 minutes. Add the palladium catalyst (0.05 eq).
- **Reaction:** Heat the mixture to 80-90 °C and stir vigorously. Monitor the reaction progress by Thin Layer Chromatography (TLC) or LC-MS. The reaction is typically complete within 4-12

hours.

- **Workup:** Once the starting material is consumed, cool the reaction to room temperature. Dilute with ethyl acetate and wash with water, followed by brine.
- **Purification:** Dry the organic layer over anhydrous Na₂SO₄, filter, and concentrate under reduced pressure. Purify the crude product by flash column chromatography on silica gel to yield the pure 3-aryl-indazole product.

“

Scientist's Note: The choice of palladium catalyst and base can be critical. For challenging couplings, more advanced catalysts (e.g., Buchwald-Hartwig type) may be necessary. Meticulous degassing is crucial to prevent catalyst degradation and ensure a high yield.

Protocol: In Vitro Kinase Activity Assay (ADP-Glo™)

The ADP-Glo™ Kinase Assay is a luminescent, homogeneous method ideal for determining IC₅₀ values by measuring kinase activity.[21] It quantifies the amount of ADP produced during the kinase reaction.[22]

Materials:

- Kinase of interest (e.g., recombinant human VEGFR-2)
- Kinase-specific substrate peptide
- ATP
- Test compounds (indazole derivatives) dissolved in DMSO
- ADP-Glo™ Reagent and Kinase Detection Reagent (Promega)[21]
- White, opaque 96- or 384-well plates

- Plate-reading luminometer

Procedure:

- Prepare Kinase Reaction: In each well of a 384-well plate, prepare a 5 μ L kinase reaction. This includes the kinase, substrate, ATP (at its K_m concentration, if known), and kinase reaction buffer.[23]
- Compound Addition: Add serial dilutions of the indazole inhibitor to the wells. Include a "no inhibitor" (DMSO only) control for 100% activity and a "no enzyme" control for background.
- Initiate Reaction: Incubate the plate at room temperature (or 30°C) for 60 minutes.
- Stop Reaction & Deplete ATP: Add 5 μ L of ADP-Glo™ Reagent to each well.[23] This terminates the kinase reaction and depletes the remaining unconsumed ATP. Incubate at room temperature for 40 minutes.[22][24]
- Detect ADP: Add 10 μ L of Kinase Detection Reagent to each well. This converts the ADP generated into ATP and provides luciferase/luciferin to generate a luminescent signal.[22]
- Measure Luminescence: Incubate at room temperature for 30-60 minutes to stabilize the signal.[23] Measure luminescence using a plate reader.
- Data Analysis: Convert luminescence readings to percent inhibition relative to controls. Plot percent inhibition versus compound concentration and fit the data to a four-parameter dose-response curve to determine the IC50 value.

Caption: Workflow for the ADP-Glo™ in vitro kinase inhibition assay.

Protocol: Cell-Based Viability/Proliferation Assay (CellTiter-Glo®)

This assay determines the number of viable cells in culture by quantifying ATP, which indicates the presence of metabolically active cells.[25][26] It's a robust method for assessing the cytotoxic or anti-proliferative effects of kinase inhibitors on cancer cell lines.

Materials:

- Cancer cell line expressing the target kinase (e.g., HUVECs for VEGFR-2, or a tumor line with amplified c-Met)
- Complete cell culture medium
- Test compounds (indazole derivatives) dissolved in DMSO
- CellTiter-Glo® Luminescent Cell Viability Reagent (Promega)[25]
- White, opaque 96-well cell culture plates
- Plate-reading luminometer

Procedure:

- Cell Seeding: Seed cells into a 96-well plate at a predetermined density (e.g., 5,000 cells/well) in 100 μ L of medium. Allow cells to adhere overnight in a CO₂ incubator.
- Compound Treatment: Prepare serial dilutions of the indazole inhibitors in culture medium. Remove the old medium from the cells and add 100 μ L of the compound-containing medium. Include DMSO-only vehicle controls.
- Incubation: Return the plate to the incubator and incubate for 72 hours (or a desired time point).
- Assay Reagent Addition: Equilibrate the plate and the CellTiter-Glo® Reagent to room temperature for ~30 minutes.[26]
- Lysis and Signal Generation: Add 100 μ L of CellTiter-Glo® Reagent directly to each well (maintaining a 1:1 ratio with the culture volume).[27]
- Signal Stabilization: Mix the contents for 2 minutes on an orbital shaker to induce cell lysis, then let the plate incubate at room temperature for 10 minutes to stabilize the luminescent signal.[26]
- Measure Luminescence: Read the luminescence using a plate-reading luminometer.

- Data Analysis: Calculate the percentage of cell viability relative to the vehicle control. Plot this against the inhibitor concentration and fit to a dose-response curve to determine the GI50 (concentration for 50% growth inhibition).

References

- Axitinib - Grokipedia. Grokipedia. [\[Link\]](#)
- An overview of the c-MET signaling pathway. PMC - NIH. [\[Link\]](#)
- Axitinib - Wikipedia. Wikipedia. [\[Link\]](#)
- Discovery and structure activity relationship study of novel indazole amide inhibitors for extracellular signal-regulated kinase1/2 (ERK1/2). PubMed. [\[Link\]](#)
- What is the mechanism of Axitinib?. Patsnap Synapse. [\[Link\]](#)
- Axitinib: A Review of its Safety and Efficacy in the Treatment of Adults with Advanced Renal Cell Carcinoma. NIH. [\[Link\]](#)
- Targeting the c-Met Signaling Pathway in Cancer. AACR Journals. [\[Link\]](#)
- Axitinib: Indications, Adverse Effects, Contraindications and Dosage. Urology Textbook. [\[Link\]](#)
- Common c-MET signaling pathways The c-MET receptor tyrosine kinase is... | Download Scientific Diagram. ResearchGate. [\[Link\]](#)
- c-MET Protein. AbbVie Science. [\[Link\]](#)
- Molecular Bases of VEGFR-2-Mediated Physiological Function and Pathological Role. Frontiers. [\[Link\]](#)
- VEGFR-2 signaling pathway and downstream mediators. The VEGFR-2... - ResearchGate. ResearchGate. [\[Link\]](#)
- Design, synthesis, and structure-activity relationships of 3-ethynyl-1H-indazoles as inhibitors of the phosphatidylinositol 3-ki. SciSpace. [\[Link\]](#)

- Development - VEGF signaling via VEGFR2 - generic cascades Pathway Map. Bio-Rad. [\[Link\]](#)
- VEGF-A/VEGFR2 signaling network in endothelial cells relevant to angiogenesis. PMC. [\[Link\]](#)
- ADP Glo Protocol. Unknown Source. [\[Link\]](#)
- Current progress, challenges and future prospects of indazoles as protein kinase inhibitors for the treatment of cancer. RSC Publishing. [\[Link\]](#)
- Current progress, challenges and future prospects of indazoles as protein kinase inhibitors for the treatment of cancer. PMC - NIH. [\[Link\]](#)
- An overview of the c-MET signaling pathway. PubMed. [\[Link\]](#)
- ADP-Glo™ Assay Formats and Step-By-Step Protocol | Download Table. ResearchGate. [\[Link\]](#)
- Using CellTiter-Glo 3D Cell Viability Assay and P3D Scaffolds. YouTube. [\[Link\]](#)
- Design, synthesis, and biological evaluation of indazole-based PLK4 inhibitors. PMC. [\[Link\]](#)
- Indazole – an emerging privileged scaffold: synthesis and its biological significance. NIH. [\[Link\]](#)
- Structures of kinase inhibitors containing an indazole moiety. ResearchGate. [\[Link\]](#)
- Recent Advances in Indazole-Containing Derivatives: Synthesis and Biological Perspectives. PMC - PubMed Central. [\[Link\]](#)
- Design, synthesis and biological evaluation of indazole derivatives as VEGFR-2 kinase inhibitors with anti-angiogenic properties. PubMed. [\[Link\]](#)
- Identification of Novel Indazole-based Inhibitors of Fibroblast Growth Factor Receptor 1 (FGFR1). Bentham Science Publishers. [\[Link\]](#)

- Discovery of novel inhibitors of Aurora kinases with indazole scaffold: In silico fragment-based and knowledge-based drug design. ResearchGate. [[Link](#)]
- Design, synthesis, and Structure-Activity Relationships (SAR) of 3-vinylindazole derivatives as new selective tropomyosin receptor kinases (Trk) inhibitors. PubMed. [[Link](#)]
- Structural Study of Selectivity Mechanisms for JNK3 and p38 α with Indazole Scaffold Probing Compounds. NIH. [[Link](#)]

Need Custom Synthesis?

BenchChem offers custom synthesis for rare earth carbides and specific isotopic labeling.

Email: info@benchchem.com or [Request Quote Online](#).

Sources

- 1. Current progress, challenges and future prospects of indazoles as protein kinase inhibitors for the treatment of cancer - RSC Advances (RSC Publishing) [pubs.rsc.org]
- 2. pdf.benchchem.com [pdf.benchchem.com]
- 3. Indazole – an emerging privileged scaffold: synthesis and its biological significance - PMC [pmc.ncbi.nlm.nih.gov]
- 4. Design, synthesis, and biological evaluation of indazole-based PLK4 inhibitors - PMC [pmc.ncbi.nlm.nih.gov]
- 5. Structural Study of Selectivity Mechanisms for JNK3 and p38 α with Indazole Scaffold Probing Compounds - PMC [pmc.ncbi.nlm.nih.gov]
- 6. Design, synthesis, and Structure-Activity Relationships (SAR) of 3-vinylindazole derivatives as new selective tropomyosin receptor kinases (Trk) inhibitors - PubMed [pubmed.ncbi.nlm.nih.gov]
- 7. Current progress, challenges and future prospects of indazoles as protein kinase inhibitors for the treatment of cancer - PMC [pmc.ncbi.nlm.nih.gov]
- 8. Axitinib: A Review of its Safety and Efficacy in the Treatment of Adults with Advanced Renal Cell Carcinoma - PMC [pmc.ncbi.nlm.nih.gov]
- 9. aacrjournals.org [aacrjournals.org]
- 10. biorbyt.com [biorbyt.com]

- [11. What is the mechanism of Axitinib? \[synapse.patsnap.com\]](#)
- [12. urology-textbook.com \[urology-textbook.com\]](#)
- [13. grokipedia.com \[grokipedia.com\]](#)
- [14. Axitinib - Wikipedia \[en.wikipedia.org\]](#)
- [15. Frontiers | Molecular Bases of VEGFR-2-Mediated Physiological Function and Pathological Role \[frontiersin.org\]](#)
- [16. VEGF-A/VEGFR2 signaling network in endothelial cells relevant to angiogenesis - PMC \[pmc.ncbi.nlm.nih.gov\]](#)
- [17. An overview of the c-MET signaling pathway - PMC \[pmc.ncbi.nlm.nih.gov\]](#)
- [18. An overview of the c-MET signaling pathway - PubMed \[pubmed.ncbi.nlm.nih.gov\]](#)
- [19. c-MET \[abbviescience.com\]](#)
- [20. researchgate.net \[researchgate.net\]](#)
- [21. ADP-Glo™ Kinase Assay Protocol \[promega.sg\]](#)
- [22. promega.com \[promega.com\]](#)
- [23. promega.com \[promega.com\]](#)
- [24. content.protocols.io \[content.protocols.io\]](#)
- [25. CellTiter-Glo® Luminescent Cell Viability Assay Protocol \[promega.kr\]](#)
- [26. promega.com \[promega.com\]](#)
- [27. promega.com \[promega.com\]](#)
- [To cite this document: BenchChem. \[Application Notes & Protocols: A Guide to Developing Kinase Inhibitors with Indazole Scaffolds\]. BenchChem, \[2026\]. \[Online PDF\]. Available at: \[https://www.benchchem.com/product/b1428494/docs#application-notes-protocols-a-guide-to-developing-kinase-inhibitors-with-indazole-scaffolds\]](#)

Disclaimer & Data Validity:

The information provided in this document is for Research Use Only (RUO) and is strictly not intended for diagnostic or therapeutic procedures. While BenchChem strives to provide accurate protocols, we make no warranties, express or implied, regarding the fitness of this product for every specific experimental setup.

Technical Support: The protocols provided are for reference purposes. Unsure if this reagent suits your experiment?

Need Industrial/Bulk Grade? [Request Custom Synthesis Quote](#)

BenchChem

Our mission is to be the trusted global source of essential and advanced chemicals, empowering scientists and researchers to drive progress in science and industry.

Contact

Address: 3281 E Guasti Rd
Ontario, CA 91761, United States
Phone: (601) 213-4426
Email: info@benchchem.com

[Contact our Ph.D. Support Team for a compatibility check](#)