

Beyond RGD: A Comparative Guide to Integrin-Binding Peptides for Researchers

Author: BenchChem Technical Support Team. **Date:** May 2026

Compound of Interest

Compound Name: *H-Val-Gln-Pro-OH*

CAS No.: 184904-53-8

Cat. No.: B14274004

[Get Quote](#)

A Senior Application Scientist's In-Depth Analysis of VQP, RGD, and Other Key Integrin-Binding Peptides for Therapeutic and Research Applications.

In the landscape of cell adhesion and signaling research, the Arginine-Glycine-Aspartic acid (RGD) motif has long been the gold standard for targeting integrins. Its discovery revolutionized our understanding of cell-extracellular matrix (ECM) interactions and paved the way for numerous therapeutic and biotechnological applications[1]. However, the quest for greater specificity and affinity has led researchers to explore alternatives. This guide provides a comprehensive comparison of the binding affinities and specificities of the well-established RGD peptides against other notable integrin-binding motifs, including an investigation into the lesser-known VQP sequence.

This guide is designed for researchers, scientists, and drug development professionals, offering an objective comparison of peptide performance supported by experimental data and methodologies. We will delve into the nuances of peptide-integrin interactions, providing the technical insights necessary to make informed decisions for your research.

The RGD Motif: A Ubiquitous Player in Cell Adhesion

The RGD sequence is the most common peptide motif responsible for cell adhesion to the ECM[1]. Found in proteins like fibronectin, vitronectin, and fibrinogen, it is recognized by a large number of integrins, a family of heterodimeric cell surface receptors[1].

The conformation of the RGD motif plays a critical role in its binding affinity and specificity. Cyclic RGD peptides, for instance, generally exhibit improved binding properties and stability compared to their linear counterparts[2][3]. This is because cyclization constrains the peptide into a conformation that is more favorable for binding to the integrin's active site[2][3].

The Enigmatic VQP Motif: An Exploration

Initial inquiries into the VQP (Valine-Glutamine-Proline) peptide motif reveal a landscape with limited public-domain data directly comparing its binding affinity to RGD peptides for integrin targeting. The VQP sequence does not appear as a canonical integrin-binding motif in the same vein as RGD. Searches for "VQP peptide" often lead to unrelated molecules such as Vasoactive Intestinal Peptide (VIP), which does not contain the VQP sequence and binds to a different class of receptors, or commercially available peptides for laboratory controls[2][4][5].

Given the lack of extensive research on VQP as a direct integrin binder, this guide will broaden its scope to include other well-characterized non-RGD integrin-binding motifs to provide a valuable comparative context for researchers seeking alternatives to RGD.

Non-RGD Integrin-Binding Peptides: Expanding the Toolkit

While RGD is a promiscuous ligand, binding to numerous integrins, other peptide sequences offer more selective targeting. For instance, the iso-Aspartate-Glycine-Arginine (isoDGR) motif has emerged as a promising alternative that can exhibit high affinity and specificity for certain integrins[6]. Additionally, other motifs found in ECM proteins, such as the Leucine-Aspartic acid-Valine (LDV) sequence in fibronectin, are known to bind to specific integrin subtypes like $\alpha4\beta1$ [7].

The development of these alternative peptides is crucial for applications requiring precise targeting to avoid off-target effects, a significant challenge with the broadly recognized RGD sequence[6].

Head-to-Head Comparison: Binding Affinities and Specificities

To provide a clear comparison, the following table summarizes the known binding affinities (often expressed as IC50 or Kd values) of different peptides to various integrin subtypes. It is important to note that these values can vary depending on the experimental setup, such as the use of linear versus cyclic peptides and the specific assay employed.

Peptide Motif	Target Integrin(s)	Reported Affinity (IC50/Kd)	Key Characteristics & References
RGD (Cyclic)	$\alpha\beta3$, $\alpha\beta5$, $\alpha5\beta1$, etc.	Low nM to μM range	Broad specificity; affinity and stability enhanced by cyclization.[2][3]
RGD (Linear)	$\alpha\beta3$, $\alpha\beta5$, $\alpha5\beta1$, etc.	Generally higher μM range	More flexible but often lower affinity and more susceptible to degradation than cyclic forms.[3]
isoDGR	$\alpha\beta3$	Low nM range	Can exhibit high affinity and specificity; derived from deamidation of asparagine in NGR motifs.[6]
LDV	$\alpha4\beta1$, $\alpha9\beta1$	μM range	Important for leukocyte adhesion; recognized by different integrins than the RGD-binding family.[7]

Note: The absence of VQP data in this table reflects the current state of publicly available scientific literature. Researchers with access to proprietary data on VQP peptides are encouraged to perform similar comparative studies.

Experimental Methodologies for Determining Binding Affinity

The quantitative data presented above are typically generated using a variety of biophysical and cell-based assays. Understanding these techniques is crucial for interpreting binding affinity data and for designing new experiments.

Surface Plasmon Resonance (SPR)

SPR is a powerful, label-free technique for measuring real-time biomolecular interactions[8][9]. It provides kinetic data on association (k_{on}) and dissociation (k_{off}) rates, from which the equilibrium dissociation constant (K_d) can be calculated.

Experimental Workflow: Surface Plasmon Resonance (SPR)

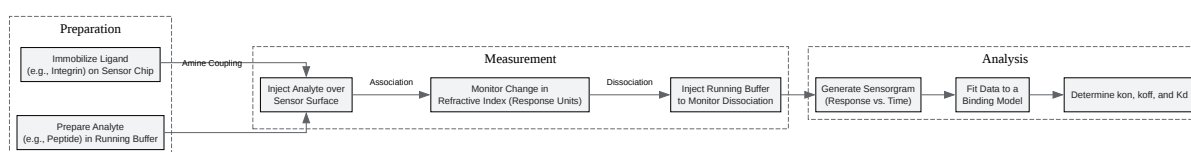

[Click to download full resolution via product page](#)

Caption: Workflow for determining peptide-integrin binding kinetics using SPR.

Enzyme-Linked Immunosorbent Assay (ELISA)-Based Binding Assays

ELISA-based assays are a common and cost-effective method for assessing binding[10][11]. In a competitive ELISA format, a known ligand is coated on a plate, and the ability of a test peptide to compete for binding to a receptor is measured.

Experimental Protocol: Competitive ELISA for Peptide Binding

- Coating: Coat a 96-well plate with a known integrin ligand (e.g., fibronectin) overnight at 4°C.
- Blocking: Wash the plate and block non-specific binding sites with a blocking buffer (e.g., BSA or non-fat milk) for 1-2 hours at room temperature.

- **Competition:** In a separate plate, pre-incubate a constant concentration of the integrin receptor with varying concentrations of the test peptide (e.g., VQP or RGD analogs).
- **Binding:** Transfer the peptide-receptor mixture to the coated plate and incubate for 1-2 hours at room temperature.
- **Detection:** Wash the plate and add a primary antibody against the integrin, followed by an enzyme-conjugated secondary antibody.
- **Substrate Addition:** Add a chromogenic substrate and measure the absorbance using a plate reader.
- **Analysis:** A decrease in signal with increasing test peptide concentration indicates competitive binding. The IC50 value can be calculated from the resulting dose-response curve.

Cell Adhesion Assays

Cell adhesion assays provide a more biologically relevant context for evaluating peptide function by measuring the ability of a peptide to inhibit cell attachment to an ECM-coated surface[12].

Diagram: Cell Adhesion Assay Workflow

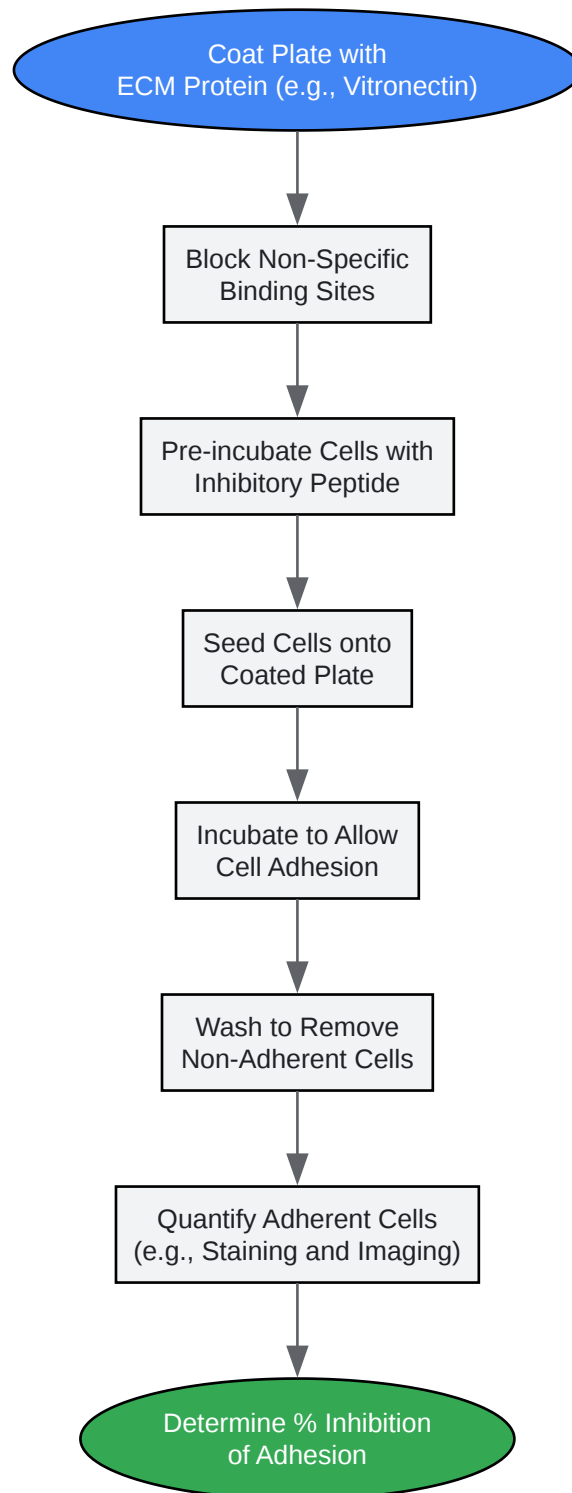

[Click to download full resolution via product page](#)

Caption: Steps involved in a typical cell adhesion inhibition assay.

Signaling Pathways: Downstream Effects of Peptide Binding

The binding of peptides to integrins can trigger intracellular signaling cascades that regulate cell survival, proliferation, and migration. While the specific pathways can vary depending on the integrin and cell type, a common pathway involves the activation of Focal Adhesion Kinase (FAK) and the subsequent activation of the Ras-ERK pathway.

Diagram: Integrin-Mediated Signaling Pathway

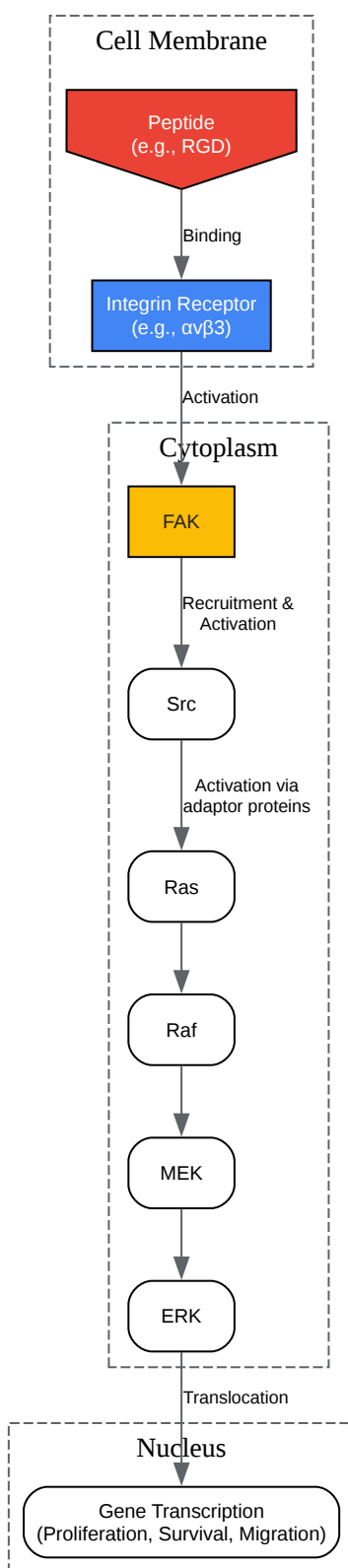

[Click to download full resolution via product page](#)

Caption: A simplified schematic of a common integrin signaling cascade.

Conclusion and Future Directions

While the RGD motif remains a cornerstone of integrin-targeting research, the exploration of alternative peptides like isoDGR and LDV offers exciting possibilities for achieving greater specificity and efficacy in therapeutic and diagnostic applications. The field's understanding of the VQP motif as an integrin binder is still nascent, and further research is required to elucidate its potential role and binding characteristics.

As our knowledge of the "integrin adhesome" expands, so too will our ability to design novel peptides with tailored binding profiles. The experimental frameworks provided in this guide offer a robust starting point for researchers looking to characterize new integrin-binding peptides and to directly compare their performance against established motifs. The continued development of high-throughput screening methods and advanced structural biology techniques will undoubtedly accelerate the discovery of the next generation of integrin-targeted molecules.

References

- Comparison of Linear vs. Cyclic RGD Pentapeptide Interactions with Integrin $\alpha\beta3$ by Molecular Dynamics Simulations - PMC. (n.d.). Retrieved from [\[Link\]](#)
- Integrin-Targeting Peptides for the Design of Functional Cell-Responsive Biomaterials - PMC. (n.d.). Retrieved from [\[Link\]](#)
- Vasoactive intestinal peptide - Wikipedia. (n.d.). Retrieved from [\[Link\]](#)
- Structural analysis of peptide binding to integrins for cancer detection and treatment - NIH. (n.d.). Retrieved from [\[Link\]](#)
- Quantitative mapping of protein-peptide affinity landscapes using spectrally encoded beads. (2019). eLife. Retrieved from [\[Link\]](#)
- VFG-Derived Peptide TLQP-21 - Bartolomucci Lab. (n.d.). Retrieved from [\[Link\]](#)
- Arginylglycylaspartic acid - Wikipedia. (n.d.). Retrieved from [\[Link\]](#)
- Additive method for the prediction of protein-peptide binding affinity. Application to the MHC class I molecule HLA-A*0201 - PubMed. (n.d.). Retrieved from [\[Link\]](#)

- Alpha(v)beta3 and alpha(v)beta5 integrins bind both the proximal RGD site and non-RGD motifs within noncollagenous (NC1) domain of the alpha3 chain of type IV collagen: implication for the mechanism of endothelia cell adhesion - PubMed. (n.d.). Retrieved from [\[Link\]](#)
- VPAC receptors: structure, molecular pharmacology and interaction with accessory proteins - PMC - PubMed Central. (n.d.). Retrieved from [\[Link\]](#)
- Sequence requirements of the FFAT-like motif for specific binding to VAP-A are revealed by NMR - PubMed. (n.d.). Retrieved from [\[Link\]](#)
- Comparison of Linear vs. Cyclic RGD Pentapeptide Interactions with Integrin $\alpha\beta3$ by Molecular Dynamics Simulations - PMC. (n.d.). Retrieved from [\[Link\]](#)
- Protein-Protein Interactions: Surface Plasmon Resonance - PubMed. (n.d.). Retrieved from [\[Link\]](#)
- VCP Peptide - Affinity Biosciences. (n.d.). Retrieved from [\[Link\]](#)
- Vasoactive intestinal peptide: cardiovascular effects - PubMed. (n.d.). Retrieved from [\[Link\]](#)
- Comparison of the RGD Motif-Containing $\alpha\beta6$ Integrin-Binding Peptides SFLAP3 and SFITGv6 for Diagnostic Application in HNSCC | Journal of Nuclear Medicine. (n.d.). Retrieved from [\[Link\]](#)
- Identification of target-binding peptide motifs by high-throughput sequencing of phage-selected peptides - PMC - NIH. (n.d.). Retrieved from [\[Link\]](#)
- isoDGR-Peptides for Integrin Targeting: Is the Time Up for RGD? - ACS Publications. (n.d.). Retrieved from [\[Link\]](#)
- Discovering sequence motifs in quantitative and qualitative peptide data. (n.d.). Retrieved from [\[Link\]](#)
- MOTIF: Searching Protein Sequence Motifs - GenomeNet. (n.d.). Retrieved from [\[Link\]](#)

- Robust quantitative modeling of peptide binding affinities for MHC molecules using physical-chemical descriptors - UTMB Research Experts. (n.d.). Retrieved from [\[Link\]](#)
- A beginner's guide to surface plasmon resonance | The Biochemist - Portland Press. (n.d.). Retrieved from [\[Link\]](#)
- VPAC receptors: structure, molecular pharmacology and interaction with accessory proteins. (n.d.). Retrieved from [\[Link\]](#)
- TLQP-21, a VGF-Derived Peptide, Prevents Ethanol-Induced Gastric Lesions: Insights into Its Mode of Action - Karger Publishers. (n.d.). Retrieved from [\[Link\]](#)
- Transmitter role of vasoactive intestinal peptide - PubMed. (n.d.). Retrieved from [\[Link\]](#)
- Vasoactive Intestinal Peptide (VIP) and VIP Receptors-Elucidation of Structure and Function for Therapeutic Applications - ResearchGate. (n.d.). Retrieved from [\[Link\]](#)
- Beyond the Matrix: The Many Non-ECM Ligands for Integrins - MDPI. (n.d.). Retrieved from [\[Link\]](#)
- Design of protein-binding peptides with controlled binding affinity: the case of SARS-CoV-2 receptor binding domain and angiotensin-converting enzyme 2 derived peptides - PMC - PubMed Central. (n.d.). Retrieved from [\[Link\]](#)
- The VGF-derived peptide TLQP-21: A new modulatory peptide for inflammatory pain. (n.d.). Retrieved from [\[Link\]](#)
- Investigating the Interaction of Cyclic RGD Peptidomimetics with $\alpha V \beta 6$ Integrin by Biochemical and Molecular Docking Studies - MDPI. (n.d.). Retrieved from [\[Link\]](#)
- RGD-independent Cell Adhesion via a Tissue Transglutaminase-Fibronectin Matrix Promotes Fibronectin Fibril Deposition and Requires Syndecan-4/2 and $\alpha 5 \beta 1$ Integrin Co-signaling - PMC - PubMed Central. (n.d.). Retrieved from [\[Link\]](#)
- Integrin blocking peptide reverses immunosuppression in experimental gliomas and improves anti-PD-1 therapy outcome - bioRxiv. (n.d.). Retrieved from [\[Link\]](#)

- Full article: Valosin-containing protein (VCP): structure, functions, and implications in neurodegenerative diseases - Taylor & Francis Online. (n.d.). Retrieved from [\[Link\]](#)
- Overview: assays for studying integrin-dependent cell adhesion - PMC - NIH. (n.d.). Retrieved from [\[Link\]](#)
- What is surface plasmon resonance (SPR)? - Cytiva. (n.d.). Retrieved from [\[Link\]](#)
- Molecular View on the iRGD Peptide Binding Mechanism: Implications for Integrin Activity and Selectivity Profiles - PubMed Central. (n.d.). Retrieved from [\[Link\]](#)
- An ELISA Based Binding and Competition Method to Rapidly Determine Ligand-receptor Interactions - JoVE. (n.d.). Retrieved from [\[Link\]](#)
- Novel Linear Peptides with High Affinity to $\alpha v \beta 3$ Integrin for Precise Tumor Identification - PMC. (n.d.). Retrieved from [\[Link\]](#)

Need Custom Synthesis?

BenchChem offers custom synthesis for rare earth carbides and specific isotopic labeling.

Email: info@benchchem.com or [Request Quote Online](#).

Sources

- [1. Arginylglycylaspartic acid - Wikipedia \[en.wikipedia.org\]](#)
- [2. m.youtube.com \[m.youtube.com\]](#)
- [3. Comparison of Linear vs. Cyclic RGD Pentapeptide Interactions with Integrin \$\alpha v \beta 3\$ by Molecular Dynamics Simulations - PMC \[pmc.ncbi.nlm.nih.gov\]](#)
- [4. Vasoactive intestinal peptide - Wikipedia \[en.wikipedia.org\]](#)
- [5. VCP Peptide | Affinity Biosciences \[affbiotech.com\]](#)
- [6. pubs.acs.org \[pubs.acs.org\]](#)
- [7. Integrin-Targeting Peptides for the Design of Functional Cell-Responsive Biomaterials - PMC \[pmc.ncbi.nlm.nih.gov\]](#)

- 8. TLQP-21, A VGF-Derived Peptide Endowed of Endocrine and Extraendocrine Properties: Focus on In Vitro Calcium Signaling - PMC [[pmc.ncbi.nlm.nih.gov](https://pubmed.ncbi.nlm.nih.gov/)]
- 9. Molecular View on the iRGD Peptide Binding Mechanism: Implications for Integrin Activity and Selectivity Profiles - PMC [[pmc.ncbi.nlm.nih.gov](https://pubmed.ncbi.nlm.nih.gov/)]
- 10. Therapeutic peptides: current applications and future directions - PMC [[pmc.ncbi.nlm.nih.gov](https://pubmed.ncbi.nlm.nih.gov/)]
- 11. [mdpi.com](https://www.mdpi.com) [[mdpi.com](https://www.mdpi.com)]
- 12. [tandfonline.com](https://www.tandfonline.com) [[tandfonline.com](https://www.tandfonline.com)]
- To cite this document: BenchChem. [Beyond RGD: A Comparative Guide to Integrin-Binding Peptides for Researchers]. BenchChem, [2026]. [Online PDF]. Available at: [<https://www.benchchem.com/product/b14274004/docs#beyond-rgd-a-comparative-guide-to-integrin-binding-peptides-for-researchers>]

Disclaimer & Data Validity:

The information provided in this document is for Research Use Only (RUO) and is strictly not intended for diagnostic or therapeutic procedures. While BenchChem strives to provide accurate protocols, we make no warranties, express or implied, regarding the fitness of this product for every specific experimental setup.

Technical Support: The protocols provided are for reference purposes. Unsure if this reagent suits your experiment?

Need Industrial/Bulk Grade? [Request Custom Synthesis Quote](#)

BenchChem

Our mission is to be the trusted global source of essential and advanced chemicals, empowering scientists and researchers to drive progress in science and industry.

Contact

Address: 3281 E Guasti Rd
Ontario, CA 91761, United States
Phone: (601) 213-4426
Email: info@benchchem.com

Contact our Ph.D. Support Team for a compatibility check