

"Methyl 2-bromopyrimidine-4-carboxylate" CAS number and molecular structure

Author: BenchChem Technical Support Team. **Date:** January 2026

Compound of Interest

Compound Name: *Methyl 2-bromopyrimidine-4-carboxylate*

Cat. No.: *B1427732*

[Get Quote](#)

An In-Depth Technical Guide to **Methyl 2-bromopyrimidine-4-carboxylate**

Abstract: This technical guide provides a comprehensive overview of **Methyl 2-bromopyrimidine-4-carboxylate**, a pivotal heterocyclic building block in modern medicinal chemistry and organic synthesis. We will delve into its fundamental physicochemical properties, molecular structure, key reactive characteristics, and its significant applications in the development of novel therapeutic agents. This document is intended for researchers, chemists, and professionals in the field of drug discovery, offering field-proven insights into the strategic use of this versatile intermediate. We will explore its role in the synthesis of kinase inhibitors and other active pharmaceutical ingredients (APIs), supported by exemplary protocols and authoritative references.

Core Compound Identification and Physicochemical Properties

Methyl 2-bromopyrimidine-4-carboxylate is a high-value brominated pyrimidine derivative that functions as a multi-functional intermediate for a vast array of chemical transformations.^[1] Its structure is characterized by a pyrimidine ring substituted with a bromine atom at the 2-position and a methyl ester group at the 4-position.^[1] This unique arrangement of functional groups provides two distinct and orthogonal sites for chemical modification, making it an exceptionally valuable scaffold in synthetic chemistry.

The bromine atom serves as a reactive handle for metal-catalyzed cross-coupling reactions, while the ester group offers a site for hydrolysis or amidation, enabling extensive molecular diversification.[1]

Molecular Structure

Caption: Molecular structure of **Methyl 2-bromopyrimidine-4-carboxylate**.

Data Summary

Property	Value	Source
CAS Number	1209459-78-8	[1][2][3]
Molecular Formula	C ₆ H ₅ BrN ₂ O ₂	[1][2][4]
Molecular Weight	217.02 g/mol	[1][2]
IUPAC Name	methyl 2-bromopyrimidine-4-carboxylate	[2]
SMILES	<chem>COC(=O)C1=NC(=NC=C1)Br</chem>	[4]
InChIKey	OAKFMNMNMOFFO-UHFFFAOYSA-N	[1][4]
Predicted XlogP	1.4	[1][4]
Monoisotopic Mass	215.95345 Da	[4]
Appearance	Solid (Typical)	N/A
Purity	≥99% (Typical)	[1]

Synthesis, Reactivity, and Strategic Applications

The pyrimidine scaffold is a cornerstone in medicinal chemistry, found in a wide range of FDA-approved drugs for oncology, infectious diseases, and neurological disorders.[5][6] **Methyl 2-bromopyrimidine-4-carboxylate** leverages this privileged structure, offering chemists a reliable starting point for constructing complex molecules.

Core Reactivity

The synthetic utility of this compound stems from the differential reactivity of its two primary functional groups.

- **C2-Bromine Atom:** The electron-deficient nature of the pyrimidine ring makes the bromine atom at the 2-position an excellent leaving group in nucleophilic aromatic substitution and a prime substrate for various metal-catalyzed cross-coupling reactions. This site is commonly targeted for Suzuki, Stille, and Negishi couplings, allowing for the facile introduction of diverse aryl, heteroaryl, or alkyl substituents.^[1] This is the primary pathway for building molecular complexity and exploring structure-activity relationships (SAR).
- **C4-Methyl Ester:** The methyl ester at the 4-position provides a secondary point for modification. It can be readily hydrolyzed to the corresponding carboxylic acid, which can then be coupled with amines to form amides, or subjected to other transformations. This versatility is crucial for modulating properties like solubility, metabolic stability, and target engagement.^[1]

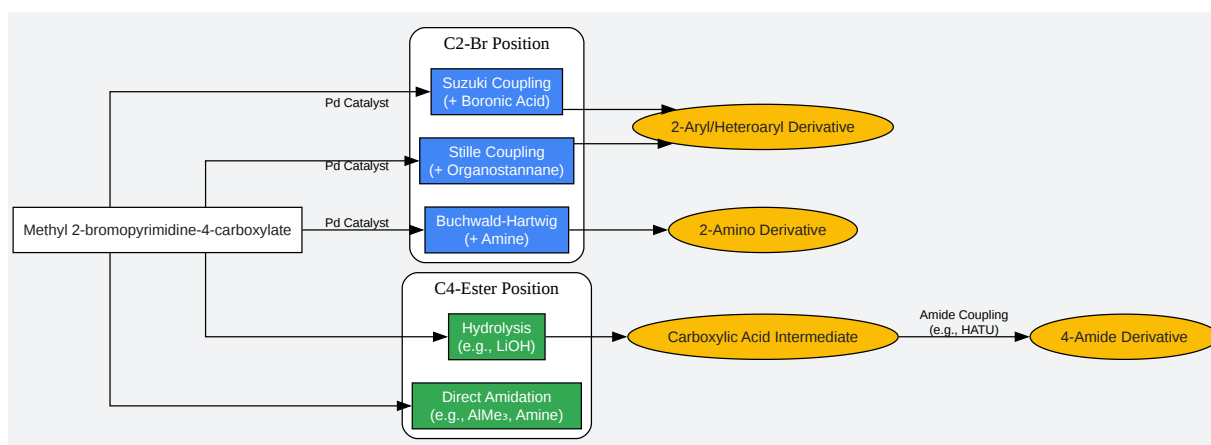

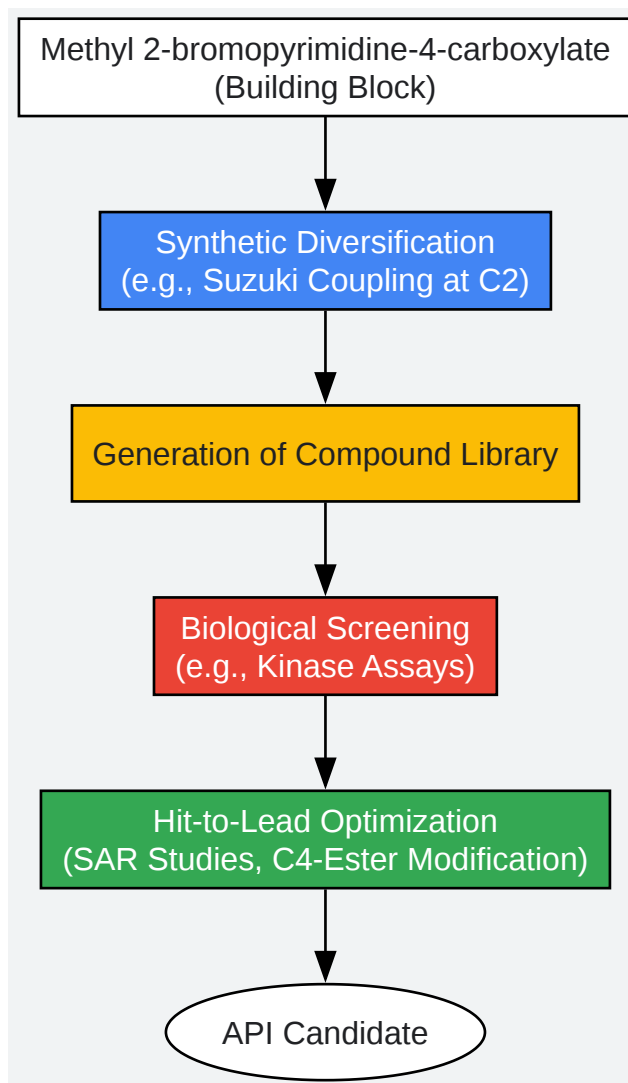

[Click to download full resolution via product page](#)

Need Custom Synthesis?

BenchChem offers custom synthesis for rare earth carbides and specific isotopic labeling.

Email: info@benchchem.com or [Request Quote Online](#).

References

- 1. Methyl 2-Bromopyrimidine-4-carboxylate|CAS 1209459-78-8 [benchchem.com]
- 2. chem-space.com [chem-space.com]
- 3. Methyl 2-broMopyriMidine-4-carboxylate | 1209459-78-8 [m.chemicalbook.com]

- 4. PubChemLite - Methyl 2-bromopyrimidine-4-carboxylate (C6H5BrN2O2) [pubchemlite.lcsb.uni.lu]
- 5. Recent Advances in Pyrimidine-Based Drugs - PMC [pmc.ncbi.nlm.nih.gov]
- 6. FDA-Approved Pyrimidine-Containing Drugs: Synthesis and Clinical Application - PubMed [pubmed.ncbi.nlm.nih.gov]
- To cite this document: BenchChem. ["Methyl 2-bromopyrimidine-4-carboxylate" CAS number and molecular structure]. BenchChem, [2026]. [Online PDF]. Available at: [https://www.benchchem.com/product/b1427732#methyl-2-bromopyrimidine-4-carboxylate-cas-number-and-molecular-structure]

Disclaimer & Data Validity:

The information provided in this document is for Research Use Only (RUO) and is strictly not intended for diagnostic or therapeutic procedures. While BenchChem strives to provide accurate protocols, we make no warranties, express or implied, regarding the fitness of this product for every specific experimental setup.

Technical Support: The protocols provided are for reference purposes. Unsure if this reagent suits your experiment? [[Contact our Ph.D. Support Team for a compatibility check](#)]

Need Industrial/Bulk Grade? [Request Custom Synthesis Quote](#)

BenchChem

Our mission is to be the trusted global source of essential and advanced chemicals, empowering scientists and researchers to drive progress in science and industry.

Contact

Address: 3281 E Guasti Rd
Ontario, CA 91761, United States
Phone: (601) 213-4426
Email: info@benchchem.com