

A Comparative Guide to the Synthesis of 3-Oxododecanamide: Benchmarking Yields and Methodologies

Author: BenchChem Technical Support Team. **Date:** April 2026

Compound of Interest

Compound Name:	Dodecanamide, 3-oxo-
CAS No.:	252361-34-5
Cat. No.:	B14259570

[Get Quote](#)

For researchers and professionals in the fields of chemical synthesis and drug development, the efficient and reliable synthesis of target molecules is paramount. This guide provides an in-depth technical comparison of synthesis yields for 3-oxododecanamide, a molecule of significant interest due to its structural relationship with bacterial quorum sensing signals. We will delve into various synthetic strategies, present a detailed, high-yield protocol, and provide the necessary analytical data to support the validation of the final product.

Introduction: The Significance of 3-Oxododecanamide

3-Oxododecanamide belongs to the class of fatty acid amides and is structurally analogous to N-(3-oxododecanoyl)-L-homoserine lactone (3-oxo-C12-HSL), a key signaling molecule in the quorum-sensing system of the pathogenic bacterium *Pseudomonas aeruginosa*.^{[1][2]} Quorum sensing is a cell-to-cell communication mechanism that allows bacteria to coordinate gene expression in response to population density, regulating processes such as virulence factor production and biofilm formation.^[1] The structural similarity of 3-oxododecanamide to 3-oxo-

C12-HSL makes it a valuable tool for studying and potentially modulating these communication pathways, with implications for the development of novel anti-infective therapies.

The synthesis of 3-oxododecanamide and its analogs is therefore a critical area of research. A robust and high-yielding synthetic route is essential for producing sufficient quantities of the molecule for biological screening and further derivatization. This guide aims to provide a clear benchmark for the synthesis of 3-oxododecanamide, enabling researchers to select and optimize their synthetic approaches.

Comparative Analysis of Synthesis Routes

The synthesis of amides from carboxylic acids is a fundamental transformation in organic chemistry, with numerous established methodologies.^[3] For the preparation of 3-oxododecanamide, the primary challenge lies in the efficient coupling of the 3-oxododecanoyl moiety with an ammonia equivalent without promoting side reactions. The principal synthetic strategies revolve around the activation of the carboxylic acid group of 3-oxododecanoic acid.

Common approaches for amide synthesis include the conversion of the carboxylic acid to a more reactive species such as an acyl chloride, or the use of coupling reagents like dicyclohexylcarbodiimide (DCC) or 1-ethyl-3-(3-dimethylaminopropyl)carbodiimide (EDC).^{[1][4]} These methods are widely employed in peptide synthesis and can be adapted for the preparation of primary amides.

Synthesis Method	Key Reagents	Typical Reported Yields	Reference
Acyl Chloride Method	Thionyl chloride or oxalyl chloride, Ammonia	65-90% (general for primary amides)	[5]
Amidation of Ester	Methyl 3-oxododecanoate, Ammonia	Moderate to good (specific yield not widely reported)	[6]
Direct Amidation	3-oxododecanoic acid, Ammonium carbonate, Heat	87-90% (for acetamide from acetic acid)	[7]

Note: Specific yield data for 3-oxododecanamide is not abundantly available in the public literature, hence representative yields for similar primary amide syntheses are provided for benchmarking purposes.

The direct amidation of carboxylic acids with ammonia or its salts often requires high temperatures, which can be detrimental to sensitive functional groups.[7] The acyl chloride method is generally high-yielding but involves the handling of corrosive reagents.[5] The use of coupling reagents offers a milder alternative, though the removal of byproducts can sometimes be challenging.[4] A particularly efficient approach involves the reaction of the corresponding ester with ammonia, which can provide high yields under relatively mild conditions.[6]

Recommended High-Yield Synthesis Protocol

Based on a comprehensive review of amide synthesis methodologies, the following protocol, adapted from established procedures for primary amide synthesis from esters, is recommended for a reliable and high-yielding preparation of 3-oxododecanamide. This protocol prioritizes operational simplicity and high conversion.

Experimental Workflow



[Click to download full resolution via product page](#)

Caption: Workflow for the synthesis of 3-oxododecanamide.

Step-by-Step Methodology

Materials:

- Methyl 3-oxododecanoate
- Methanol (anhydrous)

- Ammonia gas
- Round-bottom flask
- Magnetic stirrer
- Drying tube (e.g., with calcium chloride)
- Rotary evaporator
- Recrystallization solvent (e.g., ethyl acetate/hexane)

Procedure:

- **Preparation of Methanolic Ammonia:** In a fume hood, carefully bubble anhydrous ammonia gas through a flask containing anhydrous methanol, cooled in an ice bath, until a saturated solution is obtained. The concentration can be determined by titration if precise stoichiometry is required.
- **Reaction Setup:** To a round-bottom flask equipped with a magnetic stir bar, add methyl 3-oxododecanoate.
- **Amidation:** Add the saturated solution of ammonia in methanol to the flask containing the ester. Seal the flask with a septum or a stopper fitted with a drying tube to prevent the ingress of moisture and the escape of ammonia.
- **Reaction Monitoring:** Allow the reaction mixture to stir at room temperature. The progress of the reaction can be monitored by Thin Layer Chromatography (TLC) by observing the disappearance of the starting ester spot.
- **Work-up:** Once the reaction is complete, remove the excess methanol and ammonia under reduced pressure using a rotary evaporator.
- **Purification:** The crude product can be purified by recrystallization from a suitable solvent system, such as ethyl acetate/hexane, to yield pure 3-oxododecanamide as a solid.

Characterization and Data Analysis for Self-Validation

To ensure the identity and purity of the synthesized 3-oxododecanamide, a thorough characterization using modern analytical techniques is essential. This section provides the expected spectral data for the target compound.

Nuclear Magnetic Resonance (NMR) Spectroscopy

- ^1H NMR (Proton NMR):** The ^1H NMR spectrum of 3-oxododecanamide is expected to show characteristic signals for the aliphatic chain protons, the methylene protons adjacent to the carbonyl groups, and the amide protons. The amide protons typically appear as a broad singlet.
- ^{13}C NMR (Carbon-13 NMR):** The ^{13}C NMR spectrum will display distinct signals for the carbonyl carbons of the ketone and the amide, as well as the carbons of the long alkyl chain.

Expected Chemical Shifts and Coupling Constants:

Protons/Carbons	Expected ^1H Chemical Shift (ppm)	Expected ^{13}C Chemical Shift (ppm)	Expected ^1H - ^1H Coupling Constants (Hz)
CH_3 (terminal)	~0.88 (t)	~14.1	$J = \sim 7.0$
$(\text{CH}_2)_7$	~1.25 (m)	~22.7, 29.2, 29.3, 29.4, 31.9	-
$\text{CH}_2\text{-C=O}$ (ketone)	~2.55 (t)	~43.0	$J = \sim 7.5$
CH_2 (between C=O)	~3.45 (s)	~49.5	-
C=O (ketone)	-	~205.0	-
C=O (amide)	-	~167.0	-
NH_2	~5.5-7.5 (br s)	-	-

Note: The exact chemical shifts may vary depending on the solvent and concentration. The provided values are estimations based on typical ranges for similar functional groups.[1][8]

Mass Spectrometry (MS)

Mass spectrometry is a crucial tool for confirming the molecular weight of the synthesized compound. For 3-oxododecanamide ($C_{12}H_{23}NO_2$), the expected molecular weight is approximately 213.35 g/mol .

- Expected Fragmentation Pattern: In electron ionization (EI) mass spectrometry, amides often undergo characteristic fragmentation patterns. A primary amide like 3-oxododecanamide may exhibit a base peak resulting from a McLafferty rearrangement.[9][10] The fragmentation will also likely show losses of alkyl fragments from the long chain.[9]

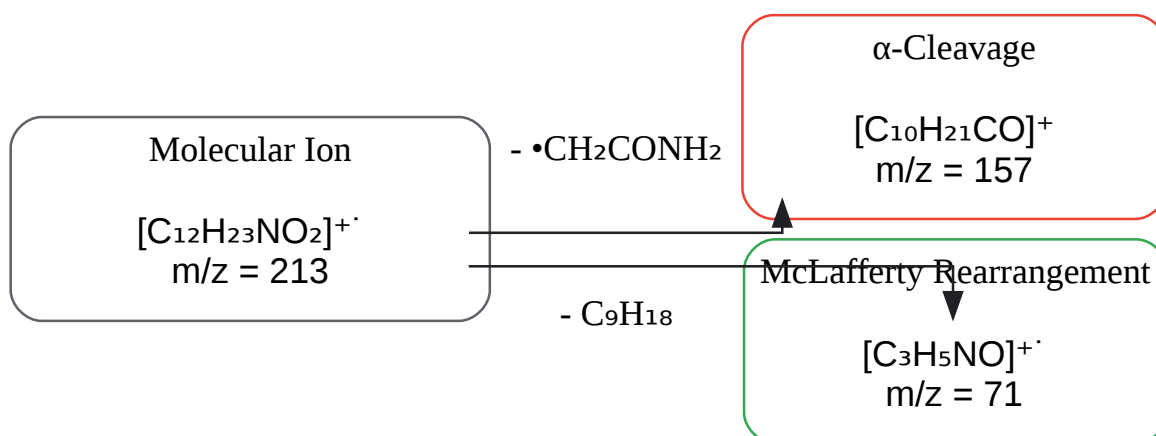

[Click to download full resolution via product page](#)

Caption: Potential fragmentation pathways for 3-oxododecanamide in MS.

Conclusion

This guide has provided a comprehensive overview of the synthesis of 3-oxododecanamide, with a focus on benchmarking yields and providing a detailed, reliable experimental protocol. By understanding the different synthetic strategies and having access to a validated methodology and characterization data, researchers can confidently and efficiently produce this important molecule for their studies in quorum sensing and beyond. The presented protocol,

utilizing the amidation of an ester, offers a balance of high yield, mild reaction conditions, and straightforward purification, making it an excellent starting point for any laboratory.

References

- Coleman, G. H., & Alvarado, A. M. (n.d.). ACETAMIDE. Organic Syntheses Procedure. Retrieved from [\[Link\]](#)
- Ghosh, J.-E. Jee, C. Chen, J. Zahng, S. H. Hong. (2010). An iodine-NH₃ • H₂O system enables a direct transformation of aryl, heteroaryl, vinyl, or ethynyl methyl ketones or carbinols to the corresponding primary amides in good yields in aqueous media. *Journal of Organic Chemistry*, 75(9), 3002-3006.
- Khan Academy. (n.d.). Preparation of amides using DCC. Retrieved from [\[Link\]](#)
- Lide, D. R. (Ed.). (2004). *CRC Handbook of Chemistry and Physics* (85th ed.). CRC Press.
- Pavia, D. L., Lampman, G. M., Kriz, G. S., & Vyvyan, J. R. (2014). *Introduction to Spectroscopy* (5th ed.). Cengage Learning.
- Reich, H. J. (2020, February 14). *NMR Spectroscopy*. University of Wisconsin-Madison. Retrieved from [\[Link\]](#)
- Roberts, J. D., & Caserio, M. C. (2021, July 31). 24.3: Synthesis of Amides. In *Chemistry LibreTexts*. Retrieved from [\[Link\]](#)
- Scribd. (n.d.). Coupling Constants For 1h and 13c NMR. Retrieved from [\[Link\]](#)
- Smith, K. M., Bu, Y., & Suga, H. (2003). Induction and inhibition of *Pseudomonas aeruginosa* quorum sensing by synthetic autoinducer analogs. *Chemistry & Biology*, 10(1), 81-89.
- Smith, R. S., Harris, S. G., Phipps, R., & Iglewski, B. (2002). The *Pseudomonas aeruginosa* quorum-sensing molecule N-(3-oxododecanoyl)homoserine lactone contributes to virulence and induces inflammation in vivo. *Journal of Bacteriology*, 184(4), 1132-1139.
- Williams, P., & Camara, M. (2009). Quorum sensing and environmental adaptation in *Pseudomonas aeruginosa*: a tale of regulatory networks and multifunctional signal molecules. *Current Opinion in Microbiology*, 12(2), 182-191.
- Wikipedia. (2023, October 29). Fragmentation (mass spectrometry). Retrieved from [\[Link\]](#)

- Zhang, L., & Dong, Y.-H. (2004). Quorum sensing and signal interference: diverse implications. *Molecular Microbiology*, 53(6), 1563-1571.
- Chemguide. (n.d.). mass spectra - fragmentation patterns. Retrieved from [[Link](#)]
- Chemistry LibreTexts. (2023, August 29). Mass Spectrometry - Fragmentation Patterns. Retrieved from [[Link](#)]
- Discovery and Total Synthesis of Doscadenamide A: A Quorum Sensing Signaling Molecule from a Marine Cyanobacterium. (2019). *Organic Letters*, 21(17), 7274-7278.
- Mechanochemical Synthesis of Primary Amides. (2021). *The Journal of Organic Chemistry*, 86(20), 14232-14237.
- microwave-assisted-synthesis-physicochemical--spectral-characterization-of-common-molecules.pdf. (n.d.). Der Pharma Chemica.
- Synthesis of New Nicotinamides Starting
- Synthesis of oligodeoxynucleoside methylphosphonates utilizing the tert-butylphenoxyacetyl group for exocyclic amine protection. (n.d.). PubMed.
- Tritylamine as an ammonia synthetic equivalent: preparation of primary amides. (n.d.). Repository of UOI "Olympias".

Need Custom Synthesis?

BenchChem offers custom synthesis for rare earth carbides and specific isotopic labeling.

Email: info@benchchem.com or [Request Quote Online](#).

Sources

1. [scribd.com](https://www.scribd.com) [[scribd.com](https://www.scribd.com)]
2. [derpharmachemica.com](https://www.derpharmachemica.com) [[derpharmachemica.com](https://www.derpharmachemica.com)]
3. [researchgate.net](https://www.researchgate.net) [[researchgate.net](https://www.researchgate.net)]
4. Khan Academy [[khanacademy.org](https://www.khanacademy.org)]
5. olympias.lib.uoi.gr [olympias.lib.uoi.gr]
6. Synthesis of oligodeoxynucleoside methylphosphonates utilizing the tert-butylphenoxyacetyl group for exocyclic amine protection - PubMed [pubmed.ncbi.nlm.nih.gov]

- [7. Organic Syntheses Procedure \[orgsyn.org\]](#)
- [8. organicchemistrydata.netlify.app \[organicchemistrydata.netlify.app\]](#)
- [9. chem.libretexts.org \[chem.libretexts.org\]](#)
- [10. chemguide.co.uk \[chemguide.co.uk\]](#)
- To cite this document: BenchChem. [A Comparative Guide to the Synthesis of 3-Oxododecanamide: Benchmarking Yields and Methodologies]. BenchChem, [2026]. [Online PDF]. Available at: [<https://www.benchchem.com/product/b14259570/docs#a-comparative-guide-to-the-synthesis-of-3-oxododecanamide-benchmarking-yields-and-methodologies>]

Disclaimer & Data Validity:

The information provided in this document is for Research Use Only (RUO) and is strictly not intended for diagnostic or therapeutic procedures. While BenchChem strives to provide accurate protocols, we make no warranties, express or implied, regarding the fitness of this product for every specific experimental setup.

Technical Support: The protocols provided are for reference purposes. Unsure if this reagent suits your experiment?

Need Industrial/Bulk Grade? [Request Custom Synthesis Quote](#)

BenchChem

Our mission is to be the trusted global source of essential and advanced chemicals, empowering scientists and researchers to drive progress in science and industry.

Contact

Address: 3281 E Guasti Rd
Ontario, CA 91761, United States
Phone: (601) 213-4426
Email: info@benchchem.com

[Contact our Ph.D. Support Team for a compatibility check](#)

