

# Application Note: Advanced Cross-Coupling Strategies for 4-Chloro-Thiazole Derivatives

**Author:** BenchChem Technical Support Team. **Date:** April 2026

## Compound of Interest

Compound Name:	4-Chloro-2-(4-fluorophenyl)thiazole-5-carbaldehyde
CAS No.:	499796-86-0
Cat. No.:	B1425549

[Get Quote](#)

## Introduction & Mechanistic Challenges

Thiazoles are privileged scaffolds in medicinal chemistry, agrochemicals, and materials science. However, functionalizing the C4 position of the thiazole ring via transition-metal catalysis presents profound mechanistic hurdles[1]. Unlike 2-halo or 5-halo thiazoles, 4-chlorothiazoles are notoriously difficult to couple due to two primary factors:

- **Electronic Deactivation:** The C4 position is relatively electron-rich, imposing a high kinetic barrier for the oxidative addition of the C(sp<sup>2</sup>)–Cl bond to Palladium(0).
- **Catalyst Poisoning:** The basic nitrogen and sulfur atoms of the thiazole ring strongly coordinate to unsaturated palladium intermediates, forming stable, off-cycle dormant complexes that halt the catalytic cycle[2].

To overcome these challenges, modern cross-coupling methodologies rely on highly engineered dialkylbiaryl phosphine ligands and precisely tuned base systems. This application

note details validated protocols for the Buchwald-Hartwig amination, Suzuki-Miyaura coupling, and C5-selective C–H functionalization of 4-chlorothiazole derivatives.

## Reaction Design & Causality

### Overcoming Off-Cycle Deactivation (Buchwald-Hartwig Amination)

When attempting C–N cross-coupling on 4-chlorothiazoles, standard ligands (e.g., BINAP, dppf) fail because the heteroarene displaces the phosphine ligand, trapping palladium in an inactive state. The Buchwald group developed GPhos, a specialized dialkylbiaryl monophosphine ligand featuring an ortho-O-tBu substituent. This structural modification enforces a conformation that prevents heteroarene coordination, keeping the catalyst on-cycle[2].

Furthermore, traditional strong bases like Sodium tert-butoxide (NaOtBu) cause rapid base-mediated ring degradation of the sensitive thiazole core. Substituting NaOtBu with Sodium trimethylsilylanolate (NaOTMS) provides a moderate-strength base that efficiently deprotonates the amine without destroying the heterocycle[2].

### Activating the C4–Cl Bond (Suzuki-Miyaura Coupling)

For C–C bond formation via Suzuki-Miyaura coupling, the high bond dissociation energy of the C4–Cl bond necessitates highly electron-rich and sterically demanding ligands. XPhos or SPhos paired with Pd<sub>2</sub>(dba)<sub>3</sub> facilitates rapid oxidative addition. Using a biphasic solvent system (1,4-Dioxane/H<sub>2</sub>O) with K<sub>3</sub>PO<sub>4</sub> ensures the rapid transmetalation of the boronic acid while maintaining the stability of the thiazole ring.

### Exploiting Innate Reactivity (C5 Dehydrogenative Heck)

If the C4 position is blocked or if orthogonal functionalization is desired, the C5 position of 4-chlorothiazole exhibits innate nucleophilicity. Palladium(II)-catalyzed dehydrogenative Heck reactions (oxidative alkenylation) can selectively occur at C5 without cleaving the C4–Cl bond, utilizing Pd(OAc)<sub>2</sub> and an oxidant like Cu(OAc)<sub>2</sub>[1].

## Visualizing Reactivity and Catalysis

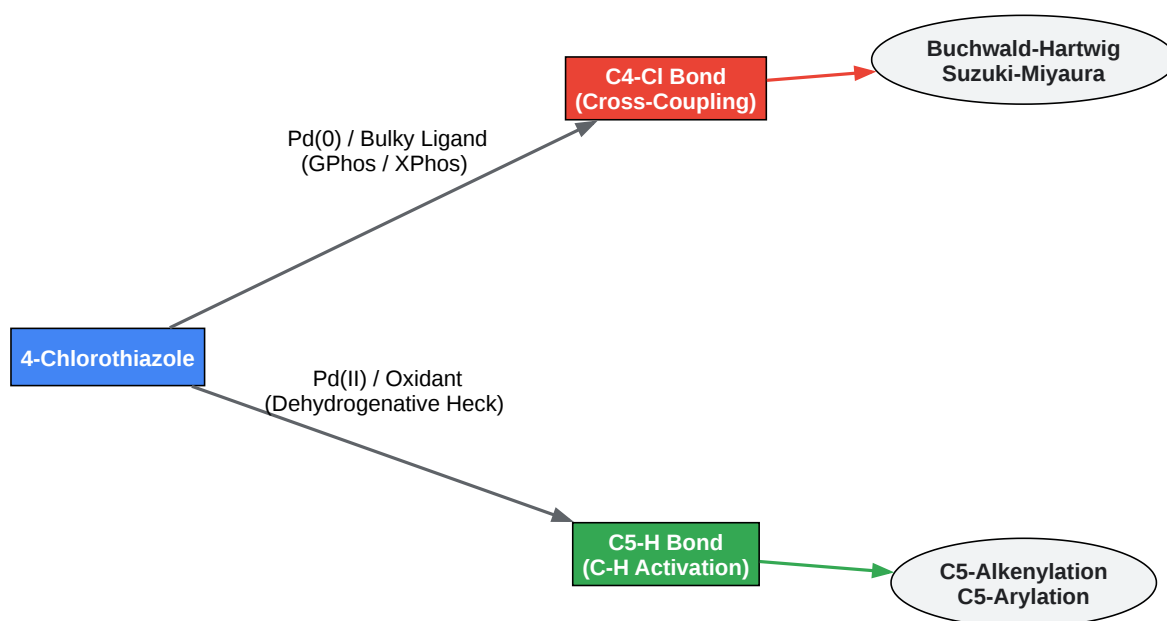

[Click to download full resolution via product page](#)

Fig 1. Divergent reactivity pathways of 4-chlorothiazole based on catalyst oxidation state.

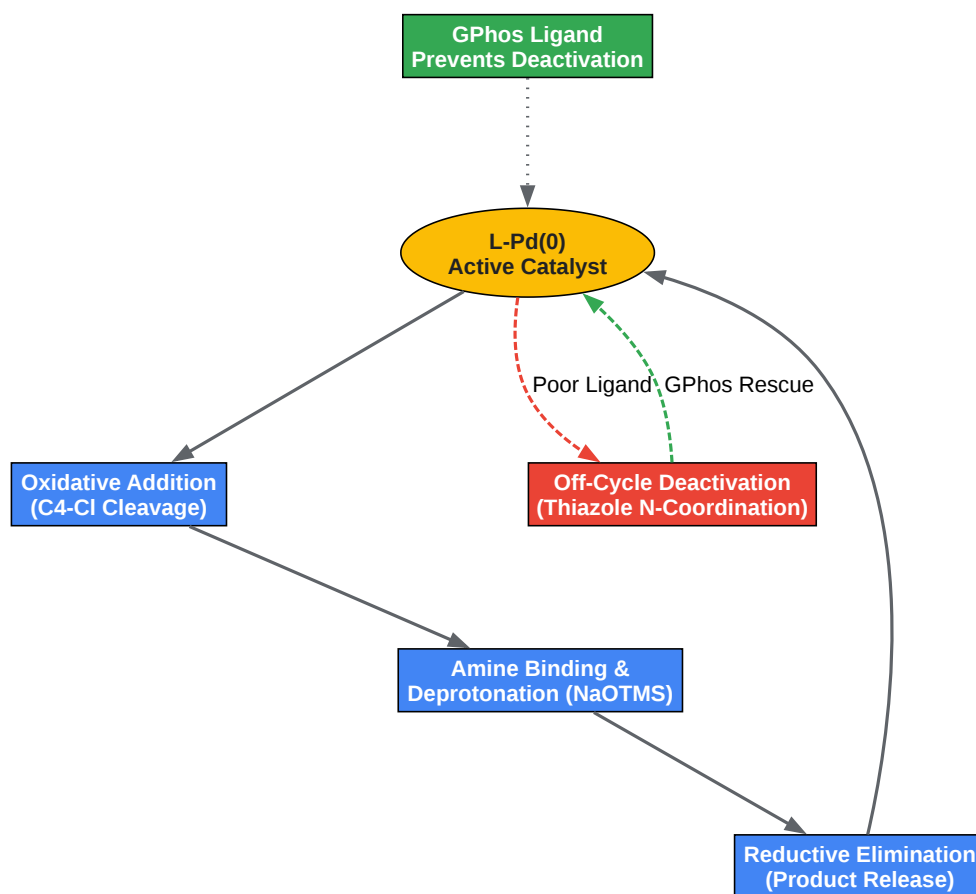

[Click to download full resolution via product page](#)

Fig 2. Buchwald-Hartwig catalytic cycle highlighting the prevention of off-cycle deactivation.

## Quantitative Data Summary

The following table summarizes the optimal parameters for functionalizing 4-chlorothiazole derivatives across different reaction modalities.

Reaction Type	Target Bond	Catalyst / Ligand	Base / Oxidant	Solvent	Temp (°C)	Expected Yield
Buchwald-Hartwig	C4-N	[Pd(cinnamyl)Cl] <sub>2</sub> / GPhos	NaOTMS (Base)	THF	50 °C	75 – 95%
Suzuki-Miyaura	C4-C(Aryl)	Pd <sub>2</sub> (dba) <sub>3</sub> / XPhos	K <sub>3</sub> PO <sub>4</sub> (Base)	Dioxane/H <sub>2</sub> O	90 – 100 °C	60 – 85%
Dehydrogenative Heck	C5- C(Alkenyl)	Pd(OAc) <sub>2</sub> / Pyridine	Cu(OAc) <sub>2</sub> (Oxidant)	DMF or DMSO	110 °C	50 – 70%

## Experimental Protocols

### Protocol A: Buchwald-Hartwig Amination of 4-Chlorothiazole

Self-Validating Design: The use of NaOTMS ensures the reaction mixture does not turn black (indicative of thiazole degradation and Pd-black precipitation). If Pd-black is observed within the first 10 minutes, verify the anhydrous nature of the THF and the integrity of the GPhos ligand[3].

Reagents:

- 4-Chlorothiazole (0.50 mmol, 1.0 equiv)
- Amine nucleophile (e.g., morpholine or primary amine) (0.60 mmol, 1.2 equiv) \*  
[Pd(cinnamyl)Cl]<sub>2</sub> (0.0025 mmol, 0.5 mol%)
- GPhos (0.005 mmol, 1.0 mol%)

- NaOTMS (1.0 mmol, 2.0 equiv)
- Anhydrous THF (2.0 mL)

#### Step-by-Step Methodology:

- **Preparation of the Catalyst Stock:** In a nitrogen-filled glovebox, pre-mix [Pd(cinnamyl)Cl]<sub>2</sub> and GPhos in 0.5 mL of anhydrous THF. Stir for 10 minutes until the solution becomes a homogeneous pale yellow, indicating the formation of the active L-Pd(0) complex.
- **Reaction Assembly:** To an oven-dried Schlenk tube equipped with a magnetic stir bar, add NaOTMS. If the amine is a solid, add it at this stage.
- **Solvent & Substrate Addition:** Seal the tube with a septum, remove from the glovebox, and connect to a Schlenk line. Inject 1.5 mL of THF, followed by the 4-chlorothiazole and the amine (if liquid).
- **Catalyst Injection:** Inject the pre-formed catalyst stock solution into the reaction mixture.
- **Heating & Monitoring:** Replace the septum with a Teflon screw cap under positive N<sub>2</sub> flow. Heat the reaction mixture in a pre-heated oil bath at 50 °C for 3–12 hours. Monitor conversion via GC-FID or LC-MS.
- **Workup:** Cool to room temperature, dilute with EtOAc (10 mL), and filter through a short pad of Celite. Concentrate the filtrate under reduced pressure and purify via flash column chromatography.

## Protocol B: Suzuki-Miyaura Coupling of 4-Chlorothiazole

**Self-Validating Design:** The biphasic nature of the solvent system requires vigorous stirring ( $\geq 800$  rpm). Failure to maintain a high stirring rate will result in stalled conversion due to poor mass transfer between the aqueous base and the organic catalytic species.

#### Reagents:

- 4-Chlorothiazole (0.50 mmol, 1.0 equiv)
- Arylboronic acid (0.75 mmol, 1.5 equiv)

- Pd<sub>2</sub>(dba)<sub>3</sub> (0.01 mmol, 2.0 mol%)
- XPhos (0.04 mmol, 8.0 mol%)
- K<sub>3</sub>PO<sub>4</sub> (1.5 mmol, 3.0 equiv)
- 1,4-Dioxane / H<sub>2</sub>O (4:1 v/v, 2.5 mL)

#### Step-by-Step Methodology:

- Degassing: Prepare a 4:1 mixture of 1,4-Dioxane and deionized water. Sparge the solvent mixture with Argon for 30 minutes prior to use.
- Solid Addition: To a 10 mL microwave vial, add the arylboronic acid, Pd<sub>2</sub>(dba)<sub>3</sub>, XPhos, and K<sub>3</sub>PO<sub>4</sub>.
- Purging: Seal the vial with a crimp cap and purge with Argon (3 vacuum/Argon cycles).
- Liquid Addition: Inject the degassed Dioxane/H<sub>2</sub>O mixture, followed by the 4-chlorothiazole via microsyringe.
- Reaction Execution: Stir the mixture vigorously (1000 rpm) at 90 °C for 16 hours.
- Workup: Cool the mixture, partition between EtOAc and water. Extract the aqueous layer twice with EtOAc. Dry the combined organic layers over anhydrous Na<sub>2</sub>SO<sub>4</sub>, filter, and concentrate for chromatographic purification.

## Protocol C: C5-Selective Dehydrogenative Heck Alkenylation

Self-Validating Design: This reaction relies on Pd(II) and requires a stoichiometric oxidant to regenerate the catalyst. The color of the reaction will shift from blue/green (Cu(II)) to a brick-red/brown suspension (Cu(I) oxide/acetate) as the reaction proceeds, acting as a visual indicator of catalytic turnover[4].

#### Reagents:

- 4-Chlorothiazole (0.50 mmol, 1.0 equiv)

- Acrylate derivative (e.g., n-butyl acrylate) (1.0 mmol, 2.0 equiv)
- Pd(OAc)<sub>2</sub> (0.05 mmol, 10 mol%)
- Cu(OAc)<sub>2</sub> (1.0 mmol, 2.0 equiv)
- Pyridine (0.10 mmol, 20 mol%)
- DMF (2.0 mL)

#### Step-by-Step Methodology:

- In a sealed tube, combine Pd(OAc)<sub>2</sub>, Cu(OAc)<sub>2</sub>, and DMF. Stir for 5 minutes.
- Add pyridine, 4-chlorothiazole, and the acrylate derivative.
- Heat the reaction mixture to 110 °C under an ambient atmosphere (or O<sub>2</sub> balloon to assist Cu turnover) for 24 hours.
- Cool to room temperature, dilute with water, and extract with EtOAc (3x). Wash the organic layer with brine to remove DMF, dry, and concentrate.

## References

- MDPI Catalysts (2020). Pd-Catalyzed Intermolecular Dehydrogenative Heck Reactions of Five-Membered Heteroarenes. Retrieved from: [\[Link\]](#)[1]
- MIT DSpace / Buchwald Group (2026). Development of Deactivation-Resistant Catalysts for Pd-Catalyzed C–N Cross-Coupling Reactions. Retrieved from: [\[Link\]](#)[2]
- MDPI Catalysts (2020). Pd-Catalyzed Intermolecular Dehydrogenative Heck Reactions of Five-Membered Heteroarenes (Detailed Mechanisms). Retrieved from: [\[Link\]](#)[4]
- Amazon S3 / Supporting Information (2026). Pd-Catalyzed Amination of Base-Sensitive Five-Membered Heteroaryl Halides with Aliphatic Amines. Retrieved from: [\[Link\]](#)[3]

### Need Custom Synthesis?

BenchChem offers custom synthesis for rare earth carbides and specific isotopic labeling.

Email: [info@benchchem.com](mailto:info@benchchem.com) or [Request Quote Online](#).

## Sources

- [1. mdpi.com](https://www.mdpi.com) [[mdpi.com](https://www.mdpi.com)]
- [2. dspace.mit.edu](https://dspace.mit.edu) [[dspace.mit.edu](https://dspace.mit.edu)]
- [3. s3-eu-west-1.amazonaws.com](https://s3-eu-west-1.amazonaws.com) [[s3-eu-west-1.amazonaws.com](https://s3-eu-west-1.amazonaws.com)]
- [4. mdpi.com](https://www.mdpi.com) [[mdpi.com](https://www.mdpi.com)]
- To cite this document: BenchChem. [Application Note: Advanced Cross-Coupling Strategies for 4-Chloro-Thiazole Derivatives]. BenchChem, [2026]. [Online PDF]. Available at: [<https://www.benchchem.com/product/b1425549/docs#application-note-advanced-cross-coupling-strategies-for-4-chloro-thiazole-derivatives>]

---

### Disclaimer & Data Validity:

The information provided in this document is for Research Use Only (RUO) and is strictly not intended for diagnostic or therapeutic procedures. While BenchChem strives to provide accurate protocols, we make no warranties, express or implied, regarding the fitness of this product for every specific experimental setup.

**Technical Support:** The protocols provided are for reference purposes. Unsure if this reagent suits your experiment?

**Need Industrial/Bulk Grade?** [Request Custom Synthesis Quote](#)

# BenchChem

Our mission is to be the trusted global source of essential and advanced chemicals, empowering scientists and researchers to drive progress in science and industry.

## Contact

Address: 3281 E Guasti Rd

Ontario, CA 91761, United States

Phone: (601) 213-4426

Email: [info@benchchem.com](mailto:info@benchchem.com)

[Contact our Ph.D. Support Team for a compatibility check](#)