

one-pot synthesis methods for 3-acetyl-2,6-dimethylindole

Author: BenchChem Technical Support Team. **Date:** April 2026

Compound of Interest

Compound Name: 1-(2,6-dimethyl-1H-indol-3-yl)ethanone

CAS No.: 1228552-84-8

Cat. No.: B1424939

[Get Quote](#)

An Application Note and Protocol for the One-Pot Synthesis of 3-acetyl-2,6-dimethylindole

Authored by: A Senior Application Scientist

Abstract

The indole scaffold is a cornerstone in medicinal chemistry, forming the structural basis for a myriad of natural products and synthetic pharmaceuticals. Among its many derivatives, 3-acetyl-2,6-dimethylindole serves as a crucial intermediate in the synthesis of various bioactive compounds. This application note presents a detailed, one-pot protocol for the efficient synthesis of 3-acetyl-2,6-dimethylindole. The described method combines the classical Fischer indole synthesis with a subsequent in-situ Friedel-Crafts acylation, offering a streamlined and resource-efficient alternative to multi-step procedures. This guide is intended for researchers, scientists, and drug development professionals, providing not only a step-by-step protocol but also a thorough explanation of the underlying reaction mechanisms and experimental rationale.

Introduction: The Significance of 3-acetyl-2,6-dimethylindole

The indole ring system is a privileged structure in drug discovery, present in numerous natural products and pharmaceutical agents.[1] The specific substitution pattern of 3-acetyl-2,6-dimethylindole makes it a versatile building block for more complex molecules. The acetyl group at the 3-position is a key functional handle for further chemical modifications, while the methyl groups at the 2- and 6-positions can influence the molecule's steric and electronic properties, impacting its biological activity and metabolic stability.

Traditional multi-step syntheses of such substituted indoles can be time-consuming, costly, and generate significant chemical waste. One-pot syntheses, where multiple reaction steps are carried out in a single reaction vessel, offer a more sustainable and efficient approach.[2] This application note details a robust one-pot method for the synthesis of 3-acetyl-2,6-dimethylindole, designed to be both high-yielding and readily scalable.

Overview of the One-Pot Synthesis Strategy

The presented one-pot synthesis of 3-acetyl-2,6-dimethylindole is a sequential combination of two classical organic reactions: the Fischer indole synthesis and the Friedel-Crafts acylation.

- **Part 1: Fischer Indole Synthesis.** This reaction forms the core indole structure from a substituted phenylhydrazine and a ketone under acidic conditions.[3][4] In this protocol, (4-methylphenyl)hydrazine hydrochloride and 2,3-butanedione are used to construct the 2,6-dimethylindole ring system.
- **Part 2: In-situ Friedel-Crafts Acylation.** Following the formation of the indole ring, the reaction conditions are adjusted to facilitate a Friedel-Crafts acylation at the electron-rich 3-position of the newly formed indole.[5][6][7] This is achieved through the introduction of an acylating agent, such as acetic anhydride, in the presence of a Lewis acid catalyst.

By carrying out these two transformations in a single pot, we eliminate the need for intermediate isolation and purification, thereby saving time, reducing solvent usage, and potentially increasing the overall yield.

Detailed Experimental Protocol

This section provides a detailed, step-by-step protocol for the one-pot synthesis of 3-acetyl-2,6-dimethylindole.

Materials and Reagents

Reagent	Formula	Molar Mass (g/mol)	Quantity (mmol)	Quantity (g or mL)
(4-Methylphenyl)hydrazine hydrochloride	C ₇ H ₁₁ ClN ₂	158.63	10	1.59 g
2,3-Butanedione	C ₄ H ₆ O ₂	86.09	12	1.03 g (1.05 mL)
Polyphosphoric acid (PPA)	(HPO ₃) _n	-	-	~15 g
Acetic anhydride	C ₄ H ₆ O ₃	102.09	15	1.53 g (1.42 mL)
Zinc chloride (ZnCl ₂), anhydrous	ZnCl ₂	136.30	11	1.50 g
Dichloromethane (DCM), anhydrous	CH ₂ Cl ₂	84.93	-	50 mL
Saturated sodium bicarbonate solution	NaHCO ₃ (aq)	-	-	As needed
Brine	NaCl(aq)	-	-	As needed
Anhydrous magnesium sulfate	MgSO ₄	120.37	-	As needed
Ethyl acetate	C ₄ H ₈ O ₂	88.11	-	For extraction
Hexane	C ₆ H ₁₄	86.18	-	For extraction

Step-by-Step Procedure

- **Reaction Setup:** To a 250 mL three-necked round-bottom flask equipped with a magnetic stirrer, a reflux condenser, and a nitrogen inlet, add (4-methylphenyl)hydrazine hydrochloride (1.59 g, 10 mmol) and polyphosphoric acid (approximately 15 g).
- **Hydrazone Formation:** Begin stirring the mixture under a nitrogen atmosphere. Slowly add 2,3-butanedione (1.05 mL, 12 mmol) to the flask at room temperature. The mixture will likely become thick and may change color.
- **Fischer Indole Synthesis:** Heat the reaction mixture to 80-90 °C and maintain this temperature for 2-3 hours. Monitor the reaction progress by Thin Layer Chromatography (TLC) until the starting materials are consumed.
- **In-situ Friedel-Crafts Acylation:** Cool the reaction mixture to room temperature. Carefully add anhydrous dichloromethane (50 mL) to the flask to dilute the mixture.
- Add anhydrous zinc chloride (1.50 g, 11 mmol) to the stirred mixture.
- Slowly add acetic anhydride (1.42 mL, 15 mmol) to the reaction mixture at room temperature.
- Stir the reaction mixture at room temperature for an additional 4-6 hours. Again, monitor the progress by TLC.
- **Work-up and Isolation:** Upon completion of the reaction, carefully quench the reaction by slowly pouring the mixture into a beaker containing ice-cold water (approximately 100 mL).
- Neutralize the aqueous mixture by the slow addition of a saturated aqueous solution of sodium bicarbonate until the effervescence ceases.
- Transfer the mixture to a separatory funnel and extract the product with a 1:1 mixture of ethyl acetate and hexane (3 x 50 mL).
- Combine the organic layers and wash with brine (50 mL).
- Dry the organic layer over anhydrous magnesium sulfate, filter, and concentrate the solvent under reduced pressure using a rotary evaporator.

- Purification: The crude product can be purified by column chromatography on silica gel using a gradient of ethyl acetate in hexane as the eluent to afford 3-acetyl-2,6-dimethylindole as a solid.

Reaction Mechanisms and Scientific Rationale

A deep understanding of the underlying reaction mechanisms is crucial for troubleshooting and optimizing the synthesis.

Fischer Indole Synthesis Mechanism

The Fischer indole synthesis proceeds through a series of well-established steps:^{[3][4]}

- Hydrazone Formation: The reaction initiates with the condensation of (4-methylphenyl)hydrazine with 2,3-butanedione to form the corresponding phenylhydrazone.
- Tautomerization: The phenylhydrazone tautomerizes to its enamine (or 'ene-hydrazine') isomer.
- [8][8]-Sigmatropic Rearrangement: Under acidic conditions (provided by PPA), the enamine undergoes a [8][8]-sigmatropic rearrangement, which is the key bond-forming step, to produce a di-imine intermediate.
- Cyclization and Aromatization: The di-imine intermediate then cyclizes and, following the elimination of an ammonia molecule, aromatizes to yield the stable 2,6-dimethylindole ring.

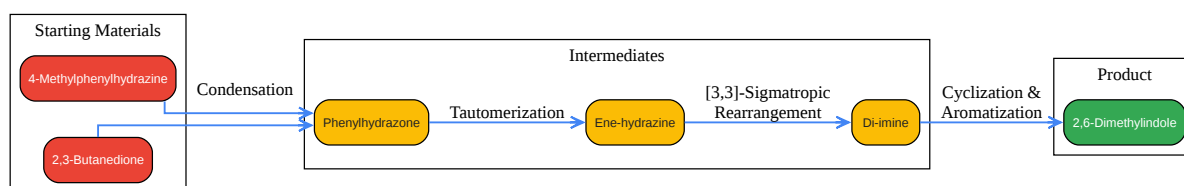

[Click to download full resolution via product page](#)

Caption: Workflow of the Fischer Indole Synthesis.

Friedel-Crafts Acylation Mechanism

The Friedel-Crafts acylation is an electrophilic aromatic substitution reaction.^{[5][7]}

- **Formation of the Acylium Ion:** The Lewis acid (ZnCl_2) activates the acetic anhydride to form a highly electrophilic acylium ion.
- **Electrophilic Attack:** The electron-rich 3-position of the 2,6-dimethylindole ring acts as a nucleophile and attacks the acylium ion, forming a resonance-stabilized carbocation intermediate (a sigma complex).
- **Deprotonation and Aromatization:** A weak base (such as the conjugate base of the acid used) removes a proton from the sigma complex, restoring the aromaticity of the indole ring and yielding the final product, 3-acetyl-2,6-dimethylindole.

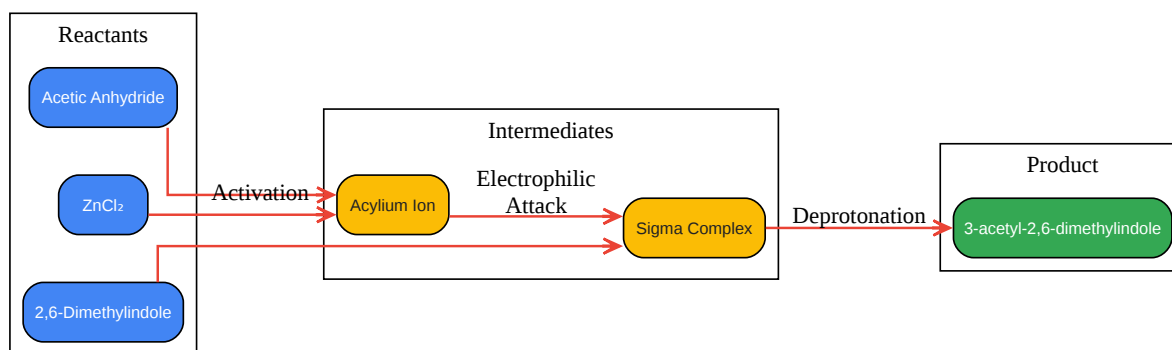

[Click to download full resolution via product page](#)

Caption: Mechanism of Friedel-Crafts Acylation.

Troubleshooting and Safety Considerations

- **Low Yields in Fischer Indole Synthesis:** Ensure that the reaction is carried out under anhydrous conditions, as water can inhibit the reaction. The temperature should be carefully controlled to avoid decomposition of the starting materials or product.
- **Formation of Side Products in Friedel-Crafts Acylation:** The acylation of indoles can sometimes lead to N-acylation or di-acylation. Using the correct stoichiometry of reagents and controlling the reaction temperature can help to minimize these side products.^[7]
- **Safety:** Polyphosphoric acid is corrosive and should be handled with care in a fume hood. Dichloromethane is a volatile and potentially carcinogenic solvent. Acetic anhydride is corrosive and a lachrymator. Appropriate personal protective equipment (PPE), including gloves, safety glasses, and a lab coat, should be worn at all times.

Conclusion

The one-pot synthesis of 3-acetyl-2,6-dimethylindole presented in this application note offers a practical and efficient method for obtaining this valuable synthetic intermediate. By combining the Fischer indole synthesis and Friedel-Crafts acylation into a single, streamlined process, this protocol reduces reaction time, solvent consumption, and waste generation. The detailed experimental procedure and mechanistic insights provided herein should enable researchers to successfully implement this methodology in their own laboratories for applications in drug discovery and organic synthesis.

References

- One-Pot Synthesis of Polysubstituted Indoles via the Indium-Promoted Regioselective Hydrohydrazination of Terminal Alkynes. (n.d.). Wiley Online Library. Retrieved from [\[Link\]](#)
- A Facile, Mild And Efficient One-Pot Synthesis of 2-Substituted Indole Derivatives Catalyzed By Pd(PPh₃)₂Cl₂. (n.d.). National Center for Biotechnology Information. Retrieved from [\[Link\]](#)
- Recent advances in catalytic approaches for the synthesis of 3-substituted indoles: mechanisms and strategies. (2025, April 17). National Center for Biotechnology Information. Retrieved from [\[Link\]](#)

- Novel and Simple Methodology for the Synthesis of 3-Acetylindoles and their N-Alkyl Derivatives Using TBAB as Phase Transfer Catalyst. (n.d.). Bentham Science. Retrieved from [\[Link\]](#)
- One-Pot Synthesis of 3-Substituted Indoles from 2-(2-Nitro-1-phenylethyl)cyclohexanone Derivatives. (2023, April 6). ACS Publications. Retrieved from [\[Link\]](#)
- Synthesis of indoles. (n.d.). Organic Chemistry Portal. Retrieved from [\[Link\]](#)
- A Simple, Effective, Green Method for the Regioselective 3-Acylation of Unprotected Indoles. (n.d.). MDPI. Retrieved from [\[Link\]](#)
- Novel method for synthesizing 3-acylated indole derivative through C-H activation. (n.d.). Google Patents.
- Acylation of Indole under Friedel–Crafts Conditions An Improved Method To Obtain 3-Acylindoles Regioselectively. (2001, March 9). ACS Publications. Retrieved from [\[Link\]](#)
- Bischler–Möhlau indole synthesis. (n.d.). Wikipedia. Retrieved from [\[Link\]](#)
- Chemistry of 3-cyanoacetyl indoles: synthesis, reactions and applications: a recent update. (2023, July 19). Royal Society of Chemistry. Retrieved from [\[Link\]](#)
- Fischer indole synthesis. (n.d.). Wikipedia. Retrieved from [\[Link\]](#)
- Mechanistic Considerations in the Synthesis of 2-Aryl-Indole Analogues under Bischler-Möhlau Conditions. (n.d.). National Center for Biotechnology Information. Retrieved from [\[Link\]](#)
- Bischler–Möhlau indole synthesis | Request PDF. (n.d.). ResearchGate. Retrieved from [\[Link\]](#)
- Bischler–Möhlau indole synthesis | 5 Publications | 202 Citations | Top Authors. (n.d.). SciSpace. Retrieved from [\[Link\]](#)
- Bischler-Möhlau indole synthesis. (n.d.). chemurope.com. Retrieved from [\[Link\]](#)
- Fischer Indole Synthesis. (n.d.). Organic Chemistry Portal. Retrieved from [\[Link\]](#)

- New 3H-Indole Synthesis by Fischer's Method. Part I. (2010, April 8). MDPI. Retrieved from [\[Link\]](#)
- One-Pot Synthesis of 2-Substituted Indoles and 7- Azaindoles via Sequential Alkynylation and Cyclization of 2-Iodo. (n.d.). Wiley Online Library. Retrieved from [\[Link\]](#)
- Synthesis of 3,3-disubstituted 2-oxindoles by deacylative alkylation and photocatalytic alkylation of olefins by zinc-sulfinates. (n.d.). Research Information System of the University of Alicante. Retrieved from [\[Link\]](#)
- Chemistry of 3-cyanoacetyl indoles: synthesis, reactions and applications: a recent update. (2023, July 19). Royal Society of Chemistry. Retrieved from [\[Link\]](#)
- A Simple, Effective, Green Method for the Regioselective 3-Acylation of Unprotected Indoles. (2015, October 27). National Center for Biotechnology Information. Retrieved from [\[Link\]](#)
- 3-acetylindole. (2017, September 4). Sciencemadness Discussion Board. Retrieved from [\[Link\]](#)
- One-pot sequential synthesis of unsymmetrical diarylmethanes using methylene chloride as a C1-synthon. (n.d.). Royal Society of Chemistry. Retrieved from [\[Link\]](#)

Need Custom Synthesis?

BenchChem offers custom synthesis for rare earth carbides and specific isotopic labeling.

Email: info@benchchem.com or [Request Quote Online](#).

Sources

- [1. A Facile, Mild And Efficient One-Pot Synthesis of 2-Substituted Indole Derivatives Catalyzed By Pd\(PPh3\)2Cl2 - PMC \[pmc.ncbi.nlm.nih.gov\]](#)
- [2. pubs.acs.org \[pubs.acs.org\]](#)
- [3. Fischer indole synthesis - Wikipedia \[en.wikipedia.org\]](#)
- [4. alfa-chemistry.com \[alfa-chemistry.com\]](#)

- [5. A Simple, Effective, Green Method for the Regioselective 3-Acylation of Unprotected Indoles - PMC \[pmc.ncbi.nlm.nih.gov\]](#)
- [6. pubs.acs.org \[pubs.acs.org\]](#)
- [7. mdpi.com \[mdpi.com\]](#)
- [8. Recent advances in catalytic approaches for the synthesis of 3-substituted indoles: mechanisms and strategies - PMC \[pmc.ncbi.nlm.nih.gov\]](#)
- To cite this document: BenchChem. [one-pot synthesis methods for 3-acetyl-2,6-dimethylindole]. BenchChem, [2026]. [Online PDF]. Available at: [<https://www.benchchem.com/product/b1424939/docs#one-pot-synthesis-methods-for-3-acetyl-2-6-dimethylindole>]

Disclaimer & Data Validity:

The information provided in this document is for Research Use Only (RUO) and is strictly not intended for diagnostic or therapeutic procedures. While BenchChem strives to provide accurate protocols, we make no warranties, express or implied, regarding the fitness of this product for every specific experimental setup.

Technical Support: The protocols provided are for reference purposes. Unsure if this reagent suits your experiment?

Need Industrial/Bulk Grade? [Request Custom Synthesis Quote](#)

BenchChem

Our mission is to be the trusted global source of essential and advanced chemicals, empowering scientists and researchers to drive progress in science and industry.

Contact

Address: 3281 E Guasti Rd
Ontario, CA 91761, United States
Phone: (601) 213-4426
Email: info@benchchem.com

Contact our Ph.D. Support Team for a compatibility check