

Protocol for end-capping PEDOT polymerization using 5-hexyl-EDOT

Author: BenchChem Technical Support Team. **Date:** April 2026

Compound of Interest

Compound Name: Thieno[3,4-b]-1,4-dioxin, 5-hexyl-2,3-dihydro-

CAS No.: 569665-30-1

Cat. No.: B14236508

[Get Quote](#)

Application Note: Precision End-Capping of PEDOT Polymerization using 5-Hexyl-EDOT

Abstract

This application note details a robust protocol for the oxidative chemical polymerization of 3,4-ethylenedioxythiophene (EDOT), explicitly utilizing 5-hexyl-3,4-ethylenedioxythiophene (5-hexyl-EDOT) as a chain-terminating agent. Unlike standard PEDOT synthesis, which often yields insoluble, intractable films, this protocol introduces a monofunctional "capping" step. This modification serves two critical functions for drug delivery and bioelectronic applications: (1) it limits molecular weight (MW) to tunable oligomeric ranges, and (2) it introduces a lipophilic hexyl tail, significantly enhancing solubility in organic solvents (e.g., CHCl₃, THF) and facilitating downstream bioconjugation or processing.

Part 1: Scientific Foundation & Mechanism

The Challenge: Uncontrolled Propagation

Standard oxidative polymerization of EDOT proceeds via the coupling of radical cations at the

-positions (C2 and C5) of the thiophene ring. Because both positions are reactive, the polymer chain grows bidirectionally and indefinitely until precipitation or side-reactions occur. This results in:

- Insolubility: High MW chains stack via

-

interactions, becoming insoluble.

- Polydispersity: Broad MW distribution makes characterization (NMR, GPC) difficult.

The Solution: The "Suicide Monomer" Strategy

The reagent 5-hexyl-EDOT functions as a chain terminator. By substituting one of the reactive -positions (C5) with an inert hexyl group, the molecule becomes monofunctional.

- Propagation: The unsubstituted C2 position couples with the growing PEDOT radical cation.
- Termination: Once incorporated, the blocked C5 position prevents further oxidative coupling at that end, effectively "capping" the chain.

Reaction Mechanism Diagram

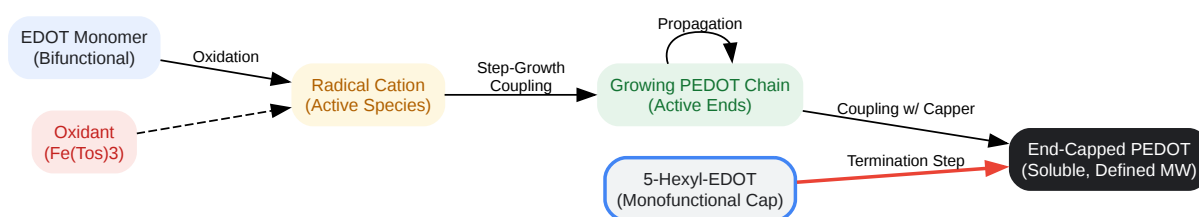

[Click to download full resolution via product page](#)

Figure 1: Mechanistic pathway of PEDOT polymerization showing the interception of the active chain end by the monofunctional 5-hexyl-EDOT terminator.

Part 2: Experimental Protocol

Safety Note: EDOT and its derivatives are toxic if inhaled or absorbed. Iron(III) tosylate is corrosive. Perform all steps in a fume hood.

Reagents & Materials

Component	Specification	Role
Monomer	3,4-Ethylenedioxythiophene (EDOT), >98%	Polymer Backbone
Terminator	5-hexyl-3,4-ethylenedioxythiophene	End-Capping Agent
Oxidant	Iron(III) p-toluenesulfonate (Fe(Tos) ₃) (40% in butanol)	Oxidizing Agent & Dopant
Base	Pyridine or Imidazole	Acid Scavenger (Controls kinetics)
Solvent	1-Butanol or Ethanol (Anhydrous)	Reaction Medium
Quench	Methanol / Hydrazine (10:1 v/v)	Stops reaction & Dedopes (optional)

Protocol Steps

Step 1: Oxidant Solution Preparation

- In a dry 50 mL flask, dilute the Fe(Tos)₃ solution (commercial 40% wt) with 1-butanol to achieve a concentration of 20 wt%.
- Add 0.5 molar equivalents of pyridine relative to iron.
 - Why? Pyridine neutralizes protons generated during coupling, preventing acid-catalyzed side reactions that lead to defects (non-conjugated linkages).

Step 2: Monomer Initiation (The "Seed")

- Prepare a separate solution of EDOT monomer in 1-butanol (0.1 M).

- Add the Oxidant Solution to the Monomer Solution dropwise under stirring at room temperature.
 - Ratio: Maintain an Oxidant:Monomer ratio of 2.3:1 (stoichiometric requirement for oxidative polymerization is 2 electrons per bond + doping charge).
- Allow polymerization to proceed for 30–60 minutes. The solution will turn dark blue/black.

Step 3: End-Capping (The Critical Step)

- Dissolve 5-hexyl-EDOT in a minimal volume of 1-butanol.
- Add the terminator solution to the active polymerization mixture.
 - Ratio Control: The amount of terminator determines the final Molecular Weight (MW).
 - Low MW (Oligomer): Add 5-hexyl-EDOT at 10–20 mol% relative to initial EDOT.
 - High MW: Add 5-hexyl-EDOT at 1–2 mol% relative to initial EDOT.
- Increase temperature to 50°C and stir for 2 hours.
 - Why? The increased temperature overcomes the activation energy barrier for the final coupling steps as the viscosity increases.

Step 4: Quenching & Purification

- Pour the reaction mixture into a 10-fold excess of Methanol.
- Optional Dedoping: If a neutral, soluble polymer is required for NMR analysis, add hydrazine monohydrate to the methanol (10% v/v). This reduces the oxidized backbone, turning it from blue (conductive) to purple/orange (neutral).
- Filter the precipitate (or collect supernatant if highly soluble).
- Soxhlet Extraction: Wash with methanol (to remove iron salts) followed by hexanes (to remove unreacted 5-hexyl-EDOT).

- Extract the final product with Chloroform (CHCl_3). The end-capped PEDOT will dissolve in chloroform, leaving uncapped/crosslinked material in the thimble.

Part 3: Workflow Visualization

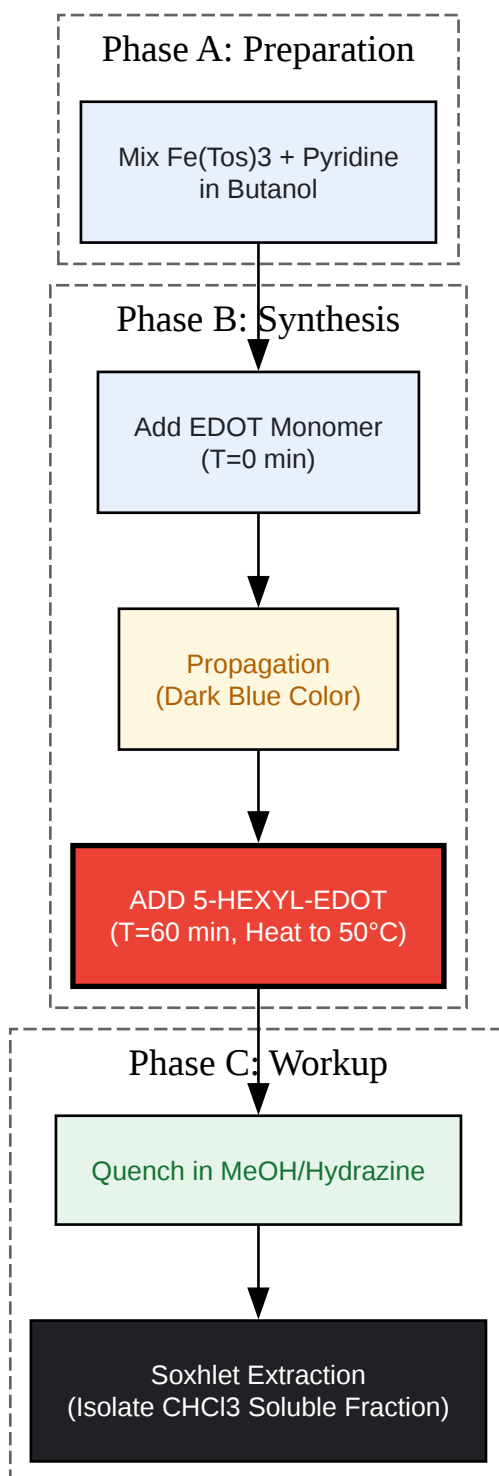

[Click to download full resolution via product page](#)

Figure 2: Step-by-step experimental workflow for the synthesis of end-capped PEDOT.

Part 4: Data Analysis & Validation

To confirm successful end-capping, the following analytical metrics should be verified.

Characterization Table

Technique	Observation for Successful Capping	Failure Mode (Uncapped)
¹ H-NMR (CDCl ₃)	Distinct triplet at ~0.9 ppm (terminal methyl of hexyl group) and multiplet at 1.2-1.5 ppm (alkyl chain). Integration ratio of Alkyl:EDOT backbone confirms MW.	Absence of alkyl peaks; polymer insoluble in CDCl ₃ .
GPC (THF)	Unimodal distribution with lower Polydispersity Index (PDI < 1.5).	Multimodal or broad peak; material gets stuck in column filter (insoluble).
UV-Vis	Defined - * transition (neutral state) or Polaron bands (doped).	Broad, featureless absorption tailing into IR (indicates aggregation).
Solubility	>10 mg/mL in Chloroform or THF.	Precipitates immediately in organic solvents.

Troubleshooting

- Issue: Polymer is still insoluble.[1]
 - Cause: Capping added too late; chains grew too long/crosslinked.

- Fix: Add 5-hexyl-EDOT earlier (e.g., at T=15 min) or increase the initial ratio of Terminator:Monomer.
- Issue: Low Conductivity.
 - Cause: Over-capping (oligomers are too short to support charge transport) or effective dedoping by hydrazine.
 - Fix: Re-dope with Nitrosyl tetrafluoroborate (NOBF₄) in acetonitrile if conductivity is required post-processing.

References

- Ha, Y. H., et al. (2004).[2] "Spectroscopic Study of the Oxidative Polymerization of 3,4-Ethylenedioxythiophene." Synthetic Metals. [Link](#)
- Jiang, L., et al. (2017). "Synthesis of Hetero-Bifunctional, End-Capped Oligo-EDOT Derivatives." Chem. [Link](#)[2][3]
- Groenendaal, L., et al. (2000). "Poly(3,4-ethylenedioxythiophene) and Its Derivatives: Past, Present, and Future." Advanced Materials. [Link](#)
- Kirchmeyer, S. & Reuter, K. (2005). "Scientific importance, properties and growing applications of poly(3,4-ethylenedioxythiophene)." Journal of Materials Chemistry. [Link](#)
- Reynolds, J. R., et al. (2019). "Soluble and Processable Conducting Polymers." [4][5] Polymer Reviews. [Link](#)

Need Custom Synthesis?

BenchChem offers custom synthesis for rare earth carbides and specific isotopic labeling.

Email: info@benchchem.com or [Request Quote Online](#).

Sources

- [1. ossila.com](https://www.ossila.com) [[ossila.com](https://www.ossila.com)]

- [2. Frontiers | Progress in Synthesis of Conductive Polymer Poly\(3,4-Ethylenedioxythiophene\) \[frontiersin.org\]](#)
- [3. Progress in Synthesis of Conductive Polymer Poly\(3,4-Ethylenedioxythiophene\) - PMC \[pmc.ncbi.nlm.nih.gov\]](#)
- [4. ossila.com \[ossila.com\]](#)
- [5. researchgate.net \[researchgate.net\]](#)
- To cite this document: BenchChem. [Protocol for end-capping PEDOT polymerization using 5-hexyl-EDOT]. BenchChem, [2026]. [Online PDF]. Available at: [\[https://www.benchchem.com/product/b14236508/docs#protocol-for-end-capping-pedot-polymerization-using-5-hexyl-edot\]](https://www.benchchem.com/product/b14236508/docs#protocol-for-end-capping-pedot-polymerization-using-5-hexyl-edot)

Disclaimer & Data Validity:

The information provided in this document is for Research Use Only (RUO) and is strictly not intended for diagnostic or therapeutic procedures. While BenchChem strives to provide accurate protocols, we make no warranties, express or implied, regarding the fitness of this product for every specific experimental setup.

Technical Support: The protocols provided are for reference purposes. Unsure if this reagent suits your experiment?

Need Industrial/Bulk Grade? [Request Custom Synthesis Quote](#)

BenchChem

Our mission is to be the trusted global source of essential and advanced chemicals, empowering scientists and researchers to drive progress in science and industry.

Contact

Address: 3281 E Guasti Rd
Ontario, CA 91761, United States
Phone: (601) 213-4426
Email: info@benchchem.com

Contact our Ph.D. Support Team for a compatibility check