

# Technical Support Center: 4-Chloro-3-(methanesulfinylmethyl)aniline Stability Guide[1]

**Author:** BenchChem Technical Support Team. **Date:** May 2026

## Compound of Interest

Compound Name: 4-Chloro-3-(methanesulfinylmethyl)aniline

CAS No.: 1250417-58-3

Cat. No.: B1423054

[Get Quote](#)

## Executive Summary

**4-Chloro-3-(methanesulfinylmethyl)aniline** (henceforth referred to as CMA-Sulfoxide) is a chemically sensitive intermediate often used in the synthesis of kinase inhibitors and high-value pharmaceuticals.[1] Its structural duality—containing both an electron-rich aniline and a redox-active benzylic sulfoxide—creates a unique stability profile.[1]

Users frequently report "purity drift" in solution. This guide addresses the three primary degradation vectors: Sulfoxide Oxidation/Reduction, Benzylic Pummerer Rearrangement, and Aniline Photo-Oxidation.

## Part 1: Critical Degradation Pathways (Visualized)

The following diagram outlines the mechanistic fate of CMA-Sulfoxide under various stress conditions. Use this to diagnose impurities in your LC-MS data.[1]

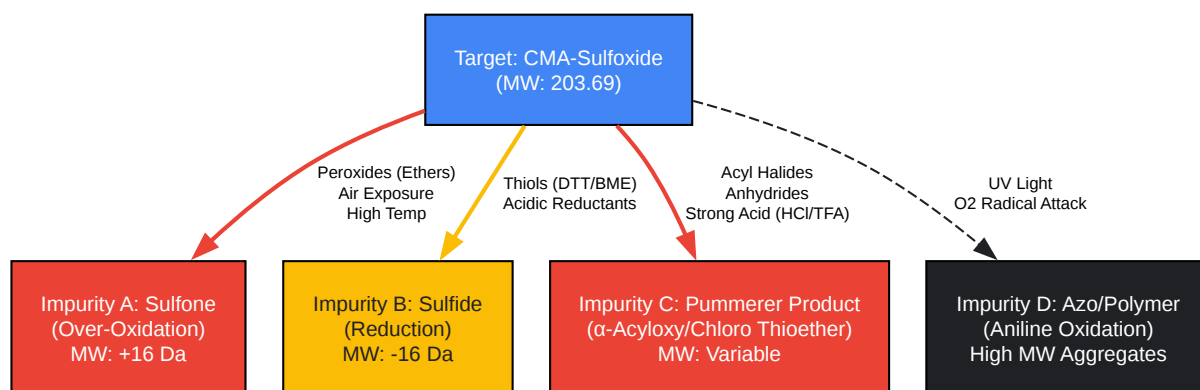

[Click to download full resolution via product page](#)

Figure 1: Primary degradation pathways for CMA-Sulfoxide.[1] Red arrows indicate critical risks in standard formulation buffers.

## Part 2: Troubleshooting & FAQs

Q1: My LC-MS shows a peak at M+16 (MW ~219). Is this a synthesis byproduct?

Diagnosis: This is likely the Sulfone derivative (4-Chloro-3-(methanesulfonylmethyl)aniline).[1]

Root Cause: Oxidative stress.[1] Sulfoxides are prone to oxidation to sulfones.[2][3]

Fix:

- Check Solvents: Are you using ethers (THF, Dioxane) or PEG? These often contain peroxides that rapidly oxidize sulfoxides [1].
- Protocol Adjustment: Switch to anhydrous Acetonitrile (MeCN) or DMSO stored under argon. Avoid "aged" solvents.

Q2: I see a new peak at M-16 (MW ~187) after leaving the sample in a biological buffer.

Diagnosis: This is the Sulfide (Thioether) derivative. Root Cause: Reductive environment.[1]

Context: If your buffer contains DTT (Dithiothreitol), BME (Beta-mercaptoethanol), or TCEP, these reducing agents can reduce the sulfoxide back to the sulfide, especially at lower pH or

elevated temperatures [2]. Solution: Remove reducing agents from the stock solution preparation. Add them only immediately prior to the assay if strictly necessary.

### Q3: The solution turned dark brown/black overnight. Is it still usable?

Diagnosis: Aniline Oxidation/Polymerization. Root Cause: Anilines are photosensitive and air-sensitive.[1] The darkening indicates the formation of azo-dimers or polyaniline-like aggregates (Impurity D in Fig 1).[1] Verdict: Discard. The effective concentration is unknown, and the polymers can interfere with optical assays (fluorescence quenching). Prevention: Store solid and solution in amber vials wrapped in foil. Flush headspace with Nitrogen/Argon.

### Q4: Can I use TFA (Trifluoroacetic acid) to solubilize the compound?

Critical Warning: NO. Mechanism: Benzylic sulfoxides are uniquely susceptible to the Pummerer Rearrangement in the presence of strong acids or acylating agents (like TFA anhydride contaminants) [3]. This rearranges the sulfoxide oxygen to the alpha-carbon, breaking the molecule or creating reactive electrophiles. Alternative: Use Formic Acid (0.1%) if acidification is needed for LC-MS, but keep the contact time short. For solubilization, use DMSO.[4]

## Part 3: Validated Handling Protocols

### Protocol A: Preparation of Stable Stock Solution (10 mM)

Target Audience: Analytical Chemists & Screeners

Parameter	Specification	Reason
Solvent	DMSO (Anhydrous, ≥99.9%)	High solubility; prevents hydrolysis.[1]
Container	Amber Glass Vial (Silanized)	Blocks UV; prevents surface adsorption.[1]
Headspace	Argon or Nitrogen	Prevents aerobic oxidation of aniline.
Storage Temp	-20°C or -80°C	Slows thermal disproportionation.[1]
Freeze/Thaw	Max 3 cycles	Repeated condensation introduces water/O <sub>2</sub> . [1]

#### Step-by-Step:

- Weigh CMA-Sulfoxide in a glovebox or reduced-light environment.[1]
- Add Anhydrous DMSO. Vortex for 30 seconds.
- QC Check: Inspect for particulates. The solution should be clear and colorless to pale yellow.
- Aliquot into single-use amber vials.
- Flush with Argon, cap tightly, and freeze immediately.

#### Protocol B: LC-MS Purity Check Methodology

Use this method to validate stock integrity before critical assays.[1]

Column: C18 Reverse Phase (e.g., Agilent ZORBAX Eclipse Plus, 2.1 x 50mm, 1.8 μm) Mobile Phase A: Water + 0.1% Formic Acid Mobile Phase B: Acetonitrile + 0.1% Formic Acid Flow Rate: 0.4 mL/min Detection: UV (254 nm) & MS (ESI+)

Gradient Table:

Time (min)	% B	Event
0.0	5	Equilibrate
0.5	5	Injection
4.0	95	Elute Impurities
5.0	95	Wash

| 5.1 | 5 | Re-equilibrate |[1]

Data Interpretation:

- RT ~2.5 min: CMA-Sulfoxide (Target).[1]
- RT ~3.2 min: Sulfone (More non-polar due to SO<sub>2</sub> symmetry).
- RT ~3.8 min: Sulfide (Most non-polar, loss of oxygen).

## Part 4: Troubleshooting Logic Flow

Follow this decision tree when you encounter stability issues.

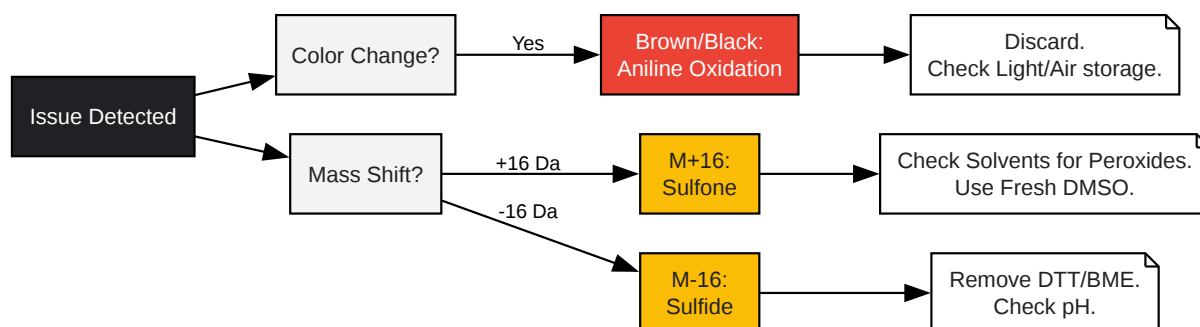

[Click to download full resolution via product page](#)

Figure 2: Decision tree for rapid diagnosis of CMA-Sulfoxide instability.

## References

- Maga, J. A. (1981). "Peroxide formation in ethers and its effect on organic reactions." *Journal of Chemical Education*, 58(11), 963. [Link](#)
- Oae, S., & Togo, H. (1983). "Reduction of Sulfoxides to Sulfides." *Bulletin of the Chemical Society of Japan*, 56(12), 3802-3812. [Link](#)
- Bur, S. K., & Padwa, A. (2004). "The Pummerer Reaction: Methodology and Strategy for the Synthesis of Heterocyclic Compounds." *Chemical Reviews*, 104(5), 2401–2432. [Link](#)

### Need Custom Synthesis?

BenchChem offers custom synthesis for rare earth carbides and specific isotopic labeling.

Email: [info@benchchem.com](mailto:info@benchchem.com) or [Request Quote Online](#).

## Sources

- 1. 4-Chloro-3-methylaniline | C7H8ClN | CID 23536 - PubChem [[pubchem.ncbi.nlm.nih.gov](https://pubchem.ncbi.nlm.nih.gov)]
- 2. Sulfoxide - Wikipedia [[en.wikipedia.org](https://en.wikipedia.org)]
- 3. Effective Oxidation of Sulfides to Sulfoxides with Hydrogen Peroxide under Transition-Metal-Free Conditions | MDPI [[mdpi.com](https://www.mdpi.com)]
- 4. [researchgate.net](https://www.researchgate.net) [[researchgate.net](https://www.researchgate.net)]
- To cite this document: BenchChem. [Technical Support Center: 4-Chloro-3-(methanesulfinylmethyl)aniline Stability Guide[1]]. BenchChem, [2026]. [Online PDF]. Available at: [<https://www.benchchem.com/product/b1423054/docs#technical-support-center-4-chloro-3-methanesulfinylmethyl-aniline-stability-guide-1>]

---

### Disclaimer & Data Validity:

The information provided in this document is for Research Use Only (RUO) and is strictly not intended for diagnostic or therapeutic procedures. While BenchChem strives to provide accurate protocols, we make no warranties, express or implied, regarding the fitness of this product for every specific experimental setup.

**Technical Support:** The protocols provided are for reference purposes. Unsure if this reagent suits your experiment?

**Need Industrial/Bulk Grade?** [Request Custom Synthesis Quote](#)

## BenchChem

Our mission is to be the trusted global source of essential and advanced chemicals, empowering scientists and researchers to drive progress in science and industry.

### Contact

Address: 3281 E Guasti Rd  
Ontario, CA 91761, United States  
Phone: (601) 213-4426  
Email: [info@benchchem.com](mailto:info@benchchem.com)

[Contact our Ph.D. Support Team for a compatibility check](#)