

# Comparative Olfactory Guide: Undec-3-en-6-one vs. -Ionone[1]

**Author:** BenchChem Technical Support Team. **Date:** April 2026

## Compound of Interest

Compound Name: *Undec-3-en-6-one*

CAS No.: 821799-91-1

Cat. No.: B14216805

[Get Quote](#)

## Executive Summary

This guide contrasts

-Ionone, the industry-standard benchmark for violet/woody odorants, with **Undec-3-en-6-one**, a linear unsaturated ketone analogue.[1] The comparison highlights the critical role of molecular cyclization in olfactory perception. While

-Ionone exhibits a characteristic floral-woody profile driven by its cyclohexene ring and conjugated enone system, **Undec-3-en-6-one** serves as a linear structural probe, exhibiting a distinct profile dominated by green, fatty, and metallic nuances typical of acyclic unsaturated ketones.[1]

## Chemical Structure & Physicochemical Properties[2][3][4][5][6][7]

The fundamental difference lies in the topology:

-Ionone is bicyclic (effective) due to the ring, whereas **Undec-3-en-6-one** is acyclic.[1] This conformational freedom vs. rigidity dictates receptor binding affinity.

**Table 1: Physicochemical Comparison**

Feature	-Ionone	Undec-3-en-6-one
CAS Number	127-41-3	10522-37-9 (isomer generic) / Research
IUPAC Name	(E)-4-(2,6,6-Trimethyl-2-cyclohexen-1-yl)-3-buten-2-one	(E)-Undec-3-en-6-one
Molecular Formula		
Molecular Weight	192.30 g/mol	168.28 g/mol
Structure Type	Cyclic -Unsaturated Ketone	Linear -Unsaturated Ketone
LogP (Predicted)	~3.7 - 4.0	~3.5 - 3.8
Vapor Pressure	0.006 mmHg @ 25°C	~0.08 mmHg @ 25°C (Est.) <sup>[1]</sup> <sup>[2]</sup>
Odor Threshold	Very Low (~0.4 ppb in air)	Moderate to High (Est. >10 ppb)

## Olfactory Profile Analysis

### -Ionone: The Cyclic Benchmark

- Primary Descriptors: Violet flower, woody (cedar-like), raspberry, orris root.<sup>[1]</sup>
- Mechanism: The specific "violet" character arises from the trimethylcyclohexene ring interacting with the enone side chain. The -isomer (double bond in the ring at C4-C5 position relative to the side chain) is sweeter and more floral than the -isomer.<sup>[1]</sup>

- Substantivity: High.[3][4][5] It acts as a middle-to-base note, providing volume and radiance. [1]

## Undec-3-en-6-one: The Linear Probe

- Primary Descriptors: Green, fatty, waxy, metallic, slightly fruity (pear/pineapple nuances).[1]
- Mechanism: Lacking the ring, this molecule cannot trigger the specific "ionone" receptors (OR5K1 type) in the same fashion. The linear chain with a mid-chain ketone and unsaturation typically yields "green-metallic" or "vegetative" notes, similar to Galbanum molecules or Undecavertol.
- Substantivity: Moderate. Higher volatility due to lower molecular weight and lack of bulky ring structure.

## Structure-Odor Relationship (SAR) Diagram

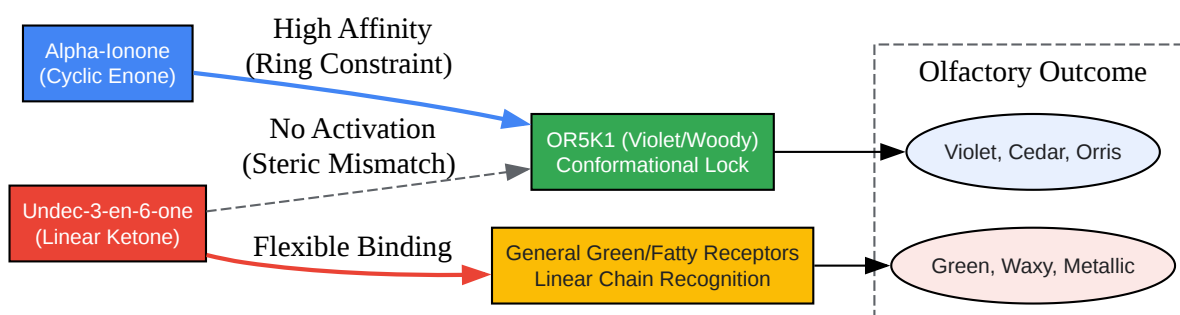

[Click to download full resolution via product page](#)

Caption: SAR comparison showing how the cyclic constraint of

-ionone targets specific violet receptors, while the flexible linear **Undec-3-en-6-one** targets general green/fatty receptors.[1]

## Experimental Protocols

To objectively validate the olfactory differences, a Gas Chromatography-Olfactometry (GC-O) workflow is recommended.[1] This allows for the separation of the molecules from a mixture

and simultaneous chemical and sensory detection.

## Protocol: GC-O Comparative Evaluation

Objective: Determine the odor detection threshold and quality of **Undec-3-en-6-one** vs.

-Ionone in a controlled matrix.

Materials:

- GC System: Agilent 7890B or equivalent with FID and Olfactory Port (ODP).
- Column: DB-Wax (Polar) and DB-5 (Non-polar) for retention index verification.[\[1\]](#)
- Panel: 3-5 trained odor assessors.[\[1\]](#)

Workflow Steps:

- Sample Preparation: Prepare 1% dilutions of both analytes in Ethanol (HPLC Grade).
- Injection: Inject 1  
  
L splitless at 250°C.
- Separation:
  - Oven Program: 50°C (2 min)  
  
10°C/min  
  
240°C (5 min).
  - The effluent is split 1:1 between the FID (Flame Ionization Detector) and the Sniffing Port.
- Data Recording:
  - Fid Signal: Records retention time and peak area.
  - Olfactorygram: Assessors record the start, stop, intensity (0-5 scale), and descriptor of the odor event.[\[1\]](#)

- AEDA (Aroma Extract Dilution Analysis): Stepwise dilution (1:2, 1:4, etc.) to determine the Flavor Dilution (FD) Factor, correlating to potency.

## Experimental Workflow Diagram

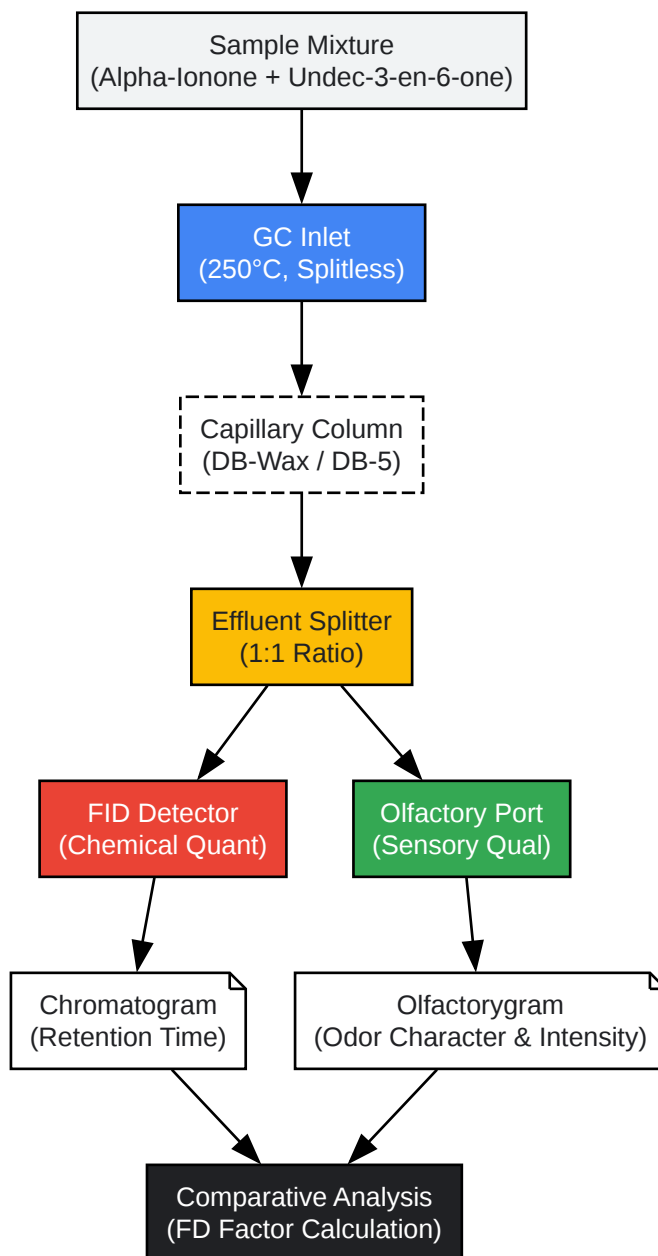

[Click to download full resolution via product page](#)

Caption: GC-O workflow for simultaneous chemical quantification and sensory evaluation of the two analytes.

## Synthesis & Stability Considerations

### -Ionone[1][7][9]

- Synthesis: Produced via the Pseudoionone route. Citral is condensed with acetone to form Pseudoionone (linear), which is then cyclized using an acid catalyst (e.g., Phosphoric acid). [1] The cyclization is the key step creating the violet odor.
- Stability: Susceptible to oxidation. Over time, it can discolor and develop "sour" off-notes if not stabilized with antioxidants (e.g., BHT).[1]

### Undec-3-en-6-one

- Synthesis: Can be synthesized via Grignard reaction or Aldol condensation variants targeting the specific chain length. For example, reacting a C4 aldehyde with a C7 ketone precursor, though specific isomer control requires catalytic directing.[1]
- Stability: As a linear enone, it is prone to polymerization or oxidation at the double bond, but generally lacks the specific discoloration issues associated with the conjugated ring system of ionones.[1]

## Conclusion

For researchers developing novel fragrances or studying olfaction:

- -Ionone remains the irreplaceable standard for violet/woody profiles due to its bicyclic shape matching specific receptor clefts.
- **Undec-3-en-6-one** acts as a negative control or a green/fatty modifier.[1] It demonstrates that merely having the same functional groups (alkene, ketone) without the ring constraint results in a completely different, often "vegetative," odor profile.[1]

## References

- Bauer, K., Garbe, D., & Surburg, H. (2001).[1] Common Fragrance and Flavor Materials: Preparation, Properties and Uses. Wiley-VCH.[1] [1]
- Ohloff, G., Surburg, H., & Pickenhagen, W. (2011).[1] Scent and Chemistry: The Molecular World of Odors. Wiley-VCH.[1] (Detailed discussion on Ionone SAR and the "Ionone Rule").

[1]

- BenchChem. (2025).[4] Beta-Ionylideneacetaldehyde and Ionone Derivatives: Synthesis and Properties. (Context on thermal isomerization and linear vs cyclic retinoid intermediates).
- PubChem. (2025).[6][7] Compound Summary: Alpha-Ionone (CID 5282108).[1] National Library of Medicine.
- The Good Scents Company. (2025). Odor Profile: Alpha-Ionone.

### Need Custom Synthesis?

BenchChem offers custom synthesis for rare earth carbides and specific isotopic labeling.

Email: [info@benchchem.com](mailto:info@benchchem.com) or [Request Quote Online](#).

## Sources

- 1. [derpharmachemica.com](https://derpharmachemica.com) [[derpharmachemica.com](https://derpharmachemica.com)]
- 2. [scent.vn](https://scent.vn) [[scent.vn](https://scent.vn)]
- 3. 6-undecanone, 927-49-1 [[thegoodscentscompany.com](https://thegoodscentscompany.com)]
- 4. beta-Ionylideneacetaldehyde|CAS 3917-41-7|RUO [[benchchem.com](https://benchchem.com)]
- 5. [pdfs.semanticscholar.org](https://pdfs.semanticscholar.org) [[pdfs.semanticscholar.org](https://pdfs.semanticscholar.org)]
- 6. Undec-3-en-2-one | C<sub>11</sub>H<sub>20</sub>O | CID 114577 - PubChem [[pubchem.ncbi.nlm.nih.gov](https://pubchem.ncbi.nlm.nih.gov)]
- 7. (E)-undec-6-en-5-one | C<sub>11</sub>H<sub>20</sub>O | CID 10986663 - PubChem [[pubchem.ncbi.nlm.nih.gov](https://pubchem.ncbi.nlm.nih.gov)]
- To cite this document: BenchChem. [Comparative Olfactory Guide: Undec-3-en-6-one vs. - Ionone[1]]. BenchChem, [2026]. [Online PDF]. Available at: [<https://www.benchchem.com/product/b14216805/docs#comparative-olfactory-guide-undec-3-en-6-one-vs-ionone-1>]

---

### Disclaimer & Data Validity:

The information provided in this document is for Research Use Only (RUO) and is strictly not intended for diagnostic or therapeutic procedures. While BenchChem strives to provide

accurate protocols, we make no warranties, express or implied, regarding the fitness of this product for every specific experimental setup.

**Technical Support:** The protocols provided are for reference purposes. Unsure if this reagent suits your experiment?

**Need Industrial/Bulk Grade?** [Request Custom Synthesis Quote](#)

## BenchChem

Our mission is to be the trusted global source of essential and advanced chemicals, empowering scientists and researchers to drive progress in science and industry.

### Contact

Address: 3281 E Guasti Rd

Ontario, CA 91761, United States

Phone: (601) 213-4426

Email: [info@benchchem.com](mailto:info@benchchem.com)

[Contact our Ph.D. Support Team for a compatibility check](#)