

Thermal gravimetric analysis (TGA) method for volatile amines

Author: BenchChem Technical Support Team. **Date:** March 2026

Compound of Interest

Compound Name:	2-ethyl-N-(2-ethylcyclohexyl)cyclohexan-1-amine
CAS No.:	1251922-64-1
Cat. No.:	B1421851

[Get Quote](#)

Application Note: Advanced Thermal Gravimetric Analysis (TGA) Strategies for Volatile Amines in Pharmaceutical Development

Abstract

Volatile amines present a unique challenge in thermal analysis due to their high vapor pressure, tendency to react with atmospheric CO

(forming carbamates), and overlapping mass-loss profiles with moisture. Standard open-pan TGA often fails to distinguish between evaporation and degradation, rendering data on stoichiometry and stability unreliable. This guide details advanced protocols using Pinhole Hermetic Encapsulation and Evolved Gas Analysis (TGA-MS) to accurately characterize volatile amines and amine salts in drug development.

The Challenge: Why Standard TGA Fails

In pharmaceutical development, amines are frequently used as counter-ions to form salts with acidic Active Pharmaceutical Ingredients (APIs) to improve solubility.[1] However, analyzing these species requires overcoming three physical hurdles:

- **Premature Evaporation:** Low-molecular-weight amines (e.g., ethylamine, diethylamine) often evaporate from standard open pans before the salt's decomposition temperature is reached,

leading to incorrect "weight loss" data that reflects volatility rather than stability.

- The "Water Masquerade": The mass loss of volatile amines often occurs in the 50°C–150°C range, perfectly overlapping with the dehydration of hydrates or surface moisture. TGA alone cannot distinguish between losing 5% water or 5% amine.
- Atmospheric Reactivity: Primary and secondary amines react rapidly with atmospheric CO

to form stable carbamates. Loading a sample in an open pan allows this reaction to occur before the run starts, altering the sample composition.

Strategic Methodology: The Decision Matrix

Effective analysis requires selecting the correct pan configuration and hyphenated technique based on the sample's physical state.

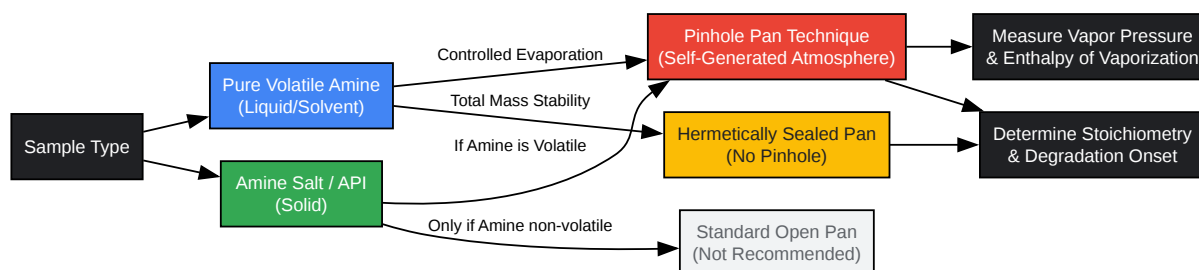

[Click to download full resolution via product page](#)

Figure 1: Decision matrix for selecting TGA pan configuration based on amine volatility and physical state.

Protocol A: The Pinhole Technique (Self-Generated Atmosphere)

This is the most critical technique for volatile amines. By sealing the sample in a hermetic pan with a laser-drilled pinhole (typically 50–75 μm), you create a "self-generated atmosphere." The amine vapor cannot escape freely; it builds up pressure inside the pan. Evaporation is suppressed until the internal vapor pressure exceeds the ambient pressure.

Objective: Shift the evaporation onset to a higher temperature to separate it from surface moisture loss.

Materials:

- Aluminum Hermetic Pans (Vol: 40 μ L).
- Lid Press/Crimper.
- Laser-drilled lids (50 μ m pinhole) OR standard lids pierced with a fine needle.

Step-by-Step Protocol:

- Blank Correction: Run an empty pinhole pan using the exact temperature program to establish the buoyancy baseline.
- Sample Loading:
 - Critical: Load the amine/salt quickly to minimize CO uptake.
 - Fill volume should be approx 10–15 μ L (liquids) or 5–10 mg (solids). Do not overfill; blocking the pinhole will cause the pan to burst.
- Sealing: Immediately crimp the lid.
- The Run:
 - Ramp: 5°C/min or 10°C/min.
 - Range: Ambient to 300°C (or decomposition).
 - Purge: Nitrogen (N) at 50 mL/min.

Data Interpretation:

- Open Pan: You will see a gradual, curving weight loss starting immediately (drying).
- Pinhole Pan: You will see a flat baseline followed by a sharp, vertical weight loss step. This "boiling point shift" confirms the volatile component. The temperature of this sharp drop correlates to the boiling point at the elevated pressure inside the pan.

Protocol B: TGA-MS for Chemical Identification

When a weight loss step is observed, TGA alone cannot confirm if it is the amine or water. Coupling TGA with Mass Spectrometry (MS) provides the chemical "fingerprint" of the evolved gas.

Objective: Deconvolute overlapping weight loss events (e.g., simultaneous loss of water and methylamine).

Hardware Setup:

- Transfer Line: Fused silica capillary, heated to 200°C minimum to prevent amine condensation (amines are "sticky" and condense easily on cold spots).
- Ionization: Electron Impact (70 eV).

Step-by-Step Protocol:

- MS Tuning: Tune the MS to scan for specific m/z ratios relevant to your expected amines (see Table 1).
- Synchronization: Ensure TGA start and MS data acquisition are triggered simultaneously.
- MID Mode: Use Multiple Ion Detection (MID) rather than full scan for higher sensitivity. Track m/z 18 (Water) and the parent/fragment ions of your amine.

Table 1: Key MS Signals for Common Pharmaceutical Volatile Amines

Compound	Molecular Weight	Primary Ion (m/z)	Secondary Fragment (m/z)	Notes
Water	18	18	17	Baseline indicator.
Ammonia	17	17	16	Overlaps with water fragment; check ratios.
Methylamine	31	30	28	Distinct from water.
Ethylamine	45	30	44	Common salt counter-ion.
Diethylamine	73	58	30	"Dog-leg" fragmentation pattern.
Triethylamine	101	86	58	High boiling point, often residual solvent.
CO	44	44	28	Indicates carbamate degradation.

Workflow Diagram:

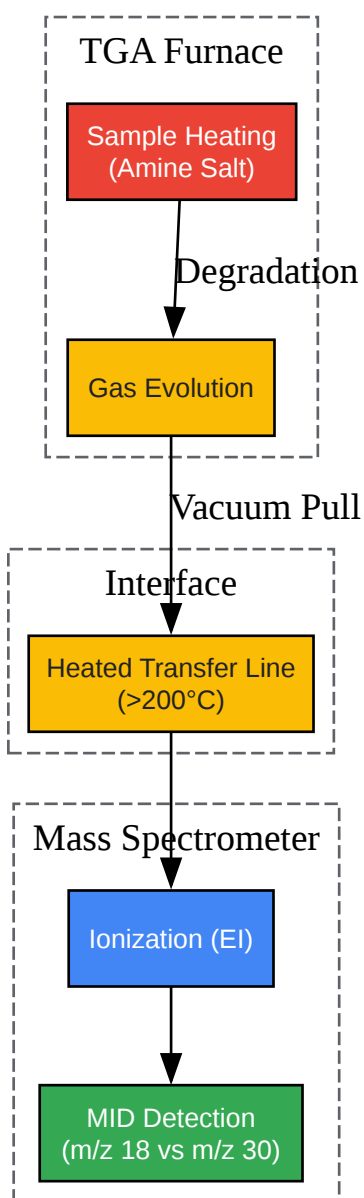

[Click to download full resolution via product page](#)

Figure 2: Data flow for TGA-MS analysis of evolved amine gases.

Protocol C: Stoichiometry Determination of Amine Salts

In drug development, verifying that a salt is a true 1:1 stoichiometry (vs. a non-stoichiometric cocrystal or solvate) is vital.

Calculation Method:

- Perform TGA using the Pinhole method to ensure the amine does not evaporate before the salt dissociation temperature.
- Identify the distinct weight loss step corresponding to the amine release (verified by MS).
- Use the following formula to validate stoichiometry:

Acceptance Criteria:

- If Experimental Mass Loss

Theoretical Mass Loss (

0.5%), the salt is stoichiometric.

- If Experimental < Theoretical, the sample may contain free base or the amine has partially evaporated prior to analysis (use a smaller pinhole).
- If Experimental > Theoretical, the sample likely contains excess solvent or moisture (check m/z 18 signal).

References

- TA Instruments. (2024). Thermal Analysis in Pharmaceutical Research, Development, and Quality Control. [Link](#)
- Mettler Toledo. (2024).[2] Evolved Gas Analysis Guide: TGA-MS and TGA-FTIR. [Link](#)
- Restek Corporation. (2011).[3] An Advanced Base-Deactivated Capillary Column for Analysis of Volatile Amines. American Laboratory. [Link](#)
- ResolveMass Laboratories. (2026). TGA Analysis in Pharmaceuticals: Thermal Stability and Decomposition. [Link](#)
- Netzsch Analysis. (2013). Factors Influencing the TGA Test Result: Pan Configuration and Purge Gas. [Link](#)

Need Custom Synthesis?

BenchChem offers custom synthesis for rare earth carbides and specific isotopic labeling.

Email: info@benchchem.com or [Request Quote Online](#).

Sources

- [1. Salts of Mefenamic Acid With Amines: Structure, Thermal Stability, Desolvation, and Solubility - PubMed \[pubmed.ncbi.nlm.nih.gov\]](#)
- [2. fkit.unizg.hr \[fkit.unizg.hr\]](#)
- [3. americanlaboratory.com \[americanlaboratory.com\]](#)
- To cite this document: BenchChem. [Thermal gravimetric analysis (TGA) method for volatile amines]. BenchChem, [2026]. [Online PDF]. Available at: [\[https://www.benchchem.com/product/b1421851#thermal-gravimetric-analysis-tga-method-for-volatile-amines\]](https://www.benchchem.com/product/b1421851#thermal-gravimetric-analysis-tga-method-for-volatile-amines)

Disclaimer & Data Validity:

The information provided in this document is for Research Use Only (RUO) and is strictly not intended for diagnostic or therapeutic procedures. While BenchChem strives to provide accurate protocols, we make no warranties, express or implied, regarding the fitness of this product for every specific experimental setup.

Technical Support: The protocols provided are for reference purposes. Unsure if this reagent suits your experiment? [[Contact our Ph.D. Support Team for a compatibility check](#)]

Need Industrial/Bulk Grade? [Request Custom Synthesis Quote](#)

BenchChem

Our mission is to be the trusted global source of essential and advanced chemicals, empowering scientists and researchers to drive progress in science and industry.

Contact

Address: 3281 E Guasti Rd
Ontario, CA 91761, United States
Phone: (601) 213-4426
Email: info@benchchem.com