

# Head-to-head synthesis efficiency with alternative fluorinated reagents

**Author:** BenchChem Technical Support Team. **Date:** May 2026

## Compound of Interest

Compound Name: *3,3-Difluoropropan-1-amine hydrochloride*  
CAS No.: *1010097-89-8*  
Cat. No.: *B1421929*

[Get Quote](#)

## Head-to-Head Synthesis Efficiency: Alternative Fluorinated Reagents

### Executive Summary: The "Fluorination Gap"

For decades, the introduction of fluorine into aliphatic scaffolds was dominated by a "reactivity vs. safety" trade-off. Reagents like DAST (Diethylaminosulfur trifluoride) offered high reactivity but came with severe thermal instability and poor chemoselectivity (often favoring elimination). [\[1\]](#)[\[2\]](#)

Modern drug development has shifted toward Late-Stage Functionalization (LSF), requiring reagents that are not only safer but capable of discriminating between complex functional groups. This guide compares the "Incumbents" (DAST, Deoxo-Fluor, Selectfluor) against the "Challengers" (PyFluor, XtalFluor, PhenoFluor) to establish a new standard for synthesis efficiency.

# Nucleophilic Fluorination: The Deoxyfluorination Showdown

The conversion of alcohols to alkyl fluorides is the most common fluorination in medicinal chemistry.

## The Incumbents vs. The Challengers

- DAST / Deoxo-Fluor: Liquid reagents.[3] Mechanism involves in situ formation of a reactive aminosulfur intermediate. Major Flaw: Violent reaction with water; thermal decomposition releases massive energy; high elimination rates in secondary alcohols.
- XtalFluor-E / -M: Crystalline aminodifluorosulfonium salts.[4] Advantage: Thermally stable; do not generate free HF (require exogenous promoter like Et<sub>3</sub>N·3HF).
- PyFluor: 2-Pyridinesulfonyl fluoride.[2][5][6] Advantage: Stable solid; distinct mechanism (sulfonyl fluoride activation) minimizes elimination; low cost.
- PhenoFluor: Imidazolium-based.[7] Advantage: Unmatched chemoselectivity for late-stage substrates; insensitive to water.

## Data Analysis: Safety and Efficiency

Table 1: Thermal Stability & Safety Profile (DSC Data) Data derived from comparative safety studies (See Ref 1, 2).

Reagent	Physical State	Onset of Decomp.[1][2] [8][9] ( )	Energy Release ( )	Hazard Rating
DAST	Fuming Liquid	~140 °C	1700 J/g	High (Explosive potential)
Deoxo-Fluor	Liquid	~140 °C	1100 J/g	High
XtalFluor-E	Crystalline Solid	215 °C	661 J/g	Low/Moderate
PyFluor	Crystalline Solid	>250 °C	Negligible	Low
PhenoFluor	Solid	213 °C	0.15 kcal/g	Low

Table 2: Reaction Performance (Secondary Alcohol Substrate) Case Study: Fluorination of Cyclooctanol (prone to elimination).

Reagent	Yield (R-F)	Elimination Byproduct	Selectivity Ratio
DAST	45%	55%	0.8 : 1
Deoxo-Fluor	50%	48%	1 : 1
XtalFluor-E	85%	10%	8.5 : 1
PyFluor	92%	<5%	>18 : 1

“

*Analyst Insight: PyFluor outperforms DAST significantly in preventing E2 elimination. This is attributed to the mechanism: DAST forms a highly leaving-group-active alkoxy-aminosulfur species that readily eliminates. PyFluor forms a sulfonate intermediate that requires a specific displacement, often suppressing the elimination pathway.*

## Mechanistic Visualization[10]

The following diagram contrasts the DAST "Explosion/Elimination" pathway with the controlled PyFluor activation.

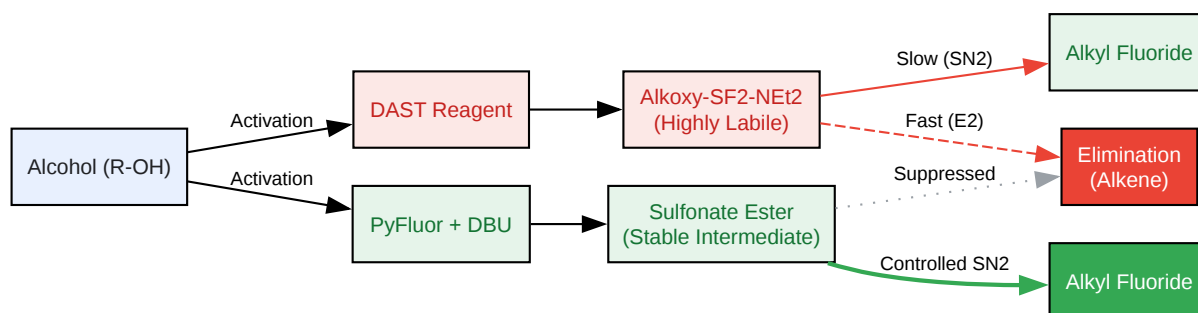

[Click to download full resolution via product page](#)

Figure 1: Mechanistic divergence. DAST intermediates are prone to rapid elimination, whereas PyFluor proceeds via a stable sulfonate ester, favoring substitution.

## Electrophilic Fluorination: The "F+" Source[11]

Used for fluorinating electron-rich centers (enolates, aromatics).[7]

## The Incumbents vs. The Challengers

- Selectfluor: The industry standard. A dicationic species (F-TEDA-BF<sub>4</sub>). Pros: Highly reactive, easy to handle solid. Cons: Low solubility in non-polar solvents; poor atom economy.

- NFSI (N-Fluorobenzenesulfonimide): Neutral reagent. Pros: Soluble in toluene/ether; milder reactivity allows for enantioselective catalysis. Cons: Slower reaction rates; requires activation (often metal catalysis).

## Efficiency Comparison

Table 3: Electrophilic Reagent Selection Guide

Feature	Selectfluor	NFSI	N-Fluoropyridinium Salts
Reactivity	High (Fluorinates enols, aromatics)	Moderate (Requires activated enolates)	Tunable (Substituent dependent)
Solubility	Polar only (MeCN, H <sub>2</sub> O)	Universal (DCM, Toluene, THF)	Moderate
Atom Economy	Poor (High MW waste)	Moderate	Moderate
Chiral Catalysis	Difficult (Insoluble in chiral pockets)	Excellent (Standard for asymmetric F)	Variable

## Experimental Protocols

These protocols are designed to be self-validating, meaning the visual cues and checkpoints ensure the user knows the reaction is proceeding correctly.

### Protocol A: Deoxyfluorination with PyFluor (High Selectivity)

Target: Conversion of a secondary alcohol to a secondary alkyl fluoride.

Reagents:

- Substrate: Secondary Alcohol (1.0 equiv)
- Reagent: PyFluor (1.2 equiv) [Ref 3]

- Base: DBU (1.5 equiv)
- Solvent: Toluene (anhydrous)

Workflow:

- Setup: Charge a flame-dried reaction vial with the Alcohol and PyFluor. Add Toluene (0.5 M concentration).
  - Checkpoint: The mixture should be a clear solution or suspension depending on substrate solubility. PyFluor is stable at RT.[2][5][9]
- Activation: Add DBU dropwise at room temperature (23 °C).
  - Observation: No violent exotherm or fuming (unlike DAST). The solution may turn slightly yellow.
- Reaction: Stir at room temperature for 12–24 hours.
  - Validation: Monitor by TLC/LCMS. The intermediate sulfonate ester may be visible by LCMS before conversion to fluoride.
- Workup: Dilute with Et<sub>2</sub>O, wash with 1N HCl (to remove DBU and Pyridine byproduct), then NaHCO<sub>3</sub>. Dry over MgSO<sub>4</sub>.
- Purification: Flash chromatography.
  - Note: Elimination byproducts are minimal, simplifying separation.[10]

## Protocol B: Enantioselective Fluorination with NFSI

Target:

-Fluorination of a

-keto ester.

Reagents:

- Substrate:  
  
-keto ester (1.0 equiv)
- Reagent: NFSI (1.2 equiv) [Ref 4]
- Catalyst: Chiral Bis(oxazoline)-Cu(II) complex (5 mol%)
- Solvent: Et<sub>2</sub>O or THF

#### Workflow:

- Catalyst Formation: Mix Cu(OTf)<sub>2</sub> and Ligand in solvent for 1 hour.
  - Checkpoint: Solution turns deep blue/green (active complex).
- Addition: Add substrate, stir 10 min, then add NFSI as a solid.
- Reaction: Stir at 0 °C to RT.
  - Causality: Lower temperature enhances enantioselectivity ( ) but slows rate. NFSI solubility is key here.
- Workup: Filter through a silica plug to remove copper salts and sulfonimide byproduct.

## Decision Matrix: When to Use What?

Do not default to DAST. Use this logic flow to select the most efficient reagent.

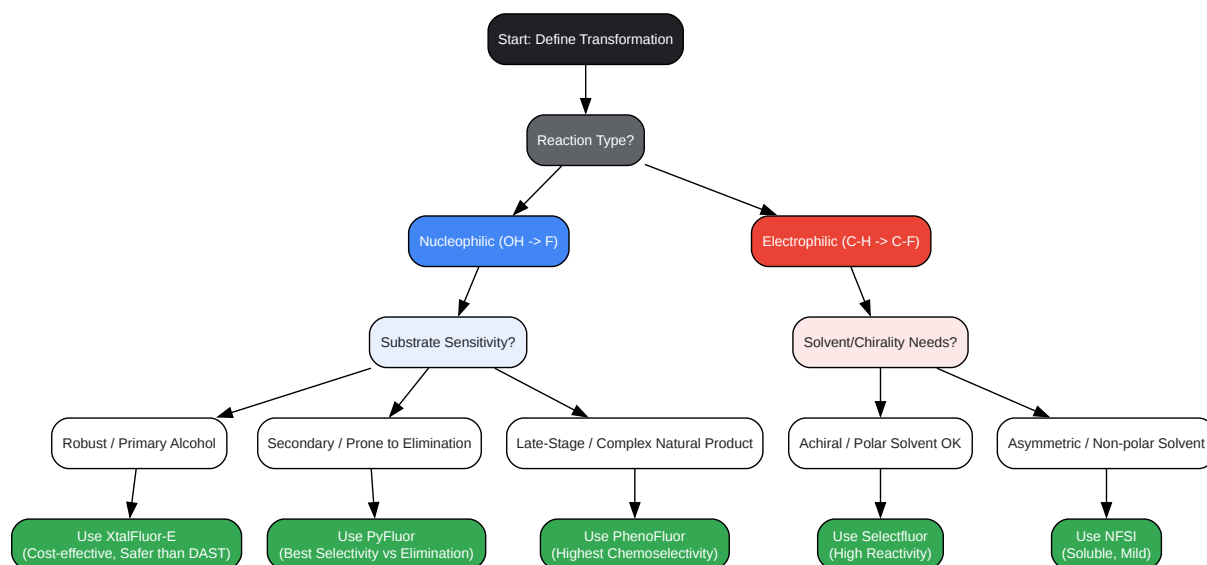

[Click to download full resolution via product page](#)

Figure 2: Reagent Selection Logic. Green nodes indicate the recommended "Modern Standard" reagent.

## References

- Beaulieu, F. et al. "Aminodifluorosulfonium Tetrafluoroborate Salts as Stable and Crystalline Deoxyfluorinating Reagents." [9] Organic Letters, 2009. [9]
- Nielsen, M. K. et al. "PyFluor: A Low-Cost, Stable, and Selective Deoxyfluorination Reagent." [6][9] Journal of the American Chemical Society, 2015. [6][9] [6]

- Doyle, A. G. et al. "PyFluor: A Low-Cost, Stable, and Selective Deoxyfluorination Reagent." [6][9] Organic Syntheses, 2016.
- T. Ishihara et al. "Electrophilic Fluorination with N-Fluorobenzenesulfonimide." Organic Syntheses, 2002.
- Fujiwara, T. et al. "Practical Synthesis of PhenoFluor." Organic Process Research & Development, 2014.

### Need Custom Synthesis?

BenchChem offers custom synthesis for rare earth carbides and specific isotopic labeling.

Email: [info@benchchem.com](mailto:info@benchchem.com) or [Request Quote Online](#).

## Sources

- 1. "Investigation of Deoxyfluorination of Alkyl Alcohols Using Pentafluoro" by Christopher Allen Bias [[researchrepository.wvu.edu](http://researchrepository.wvu.edu)]
- 2. Deoxyfluorination with 2-Pyridinesulfonyl Fluoride (PyFluor) [[sigmaaldrich.com](http://sigmaaldrich.com)]
- 3. Simpler fluorine chemistry [[soci.org](http://soci.org)]
- 4. [pubs.acs.org](http://pubs.acs.org) [[pubs.acs.org](http://pubs.acs.org)]
- 5. PyFluor - Enamine [[enamine.net](http://enamine.net)]
- 6. [doyle.chem.ucla.edu](http://doyle.chem.ucla.edu) [[doyle.chem.ucla.edu](http://doyle.chem.ucla.edu)]
- 7. [thieme-connect.com](http://thieme-connect.com) [[thieme-connect.com](http://thieme-connect.com)]
- 8. Late-Stage Deoxyfluorination of Alcohols with PhenoFluor™ - PMC [[pmc.ncbi.nlm.nih.gov](http://pmc.ncbi.nlm.nih.gov)]
- 9. Fluoroalkane synthesis by fluorination or substitution [[organic-chemistry.org](http://organic-chemistry.org)]
- 10. [pubs.acs.org](http://pubs.acs.org) [[pubs.acs.org](http://pubs.acs.org)]
- To cite this document: BenchChem. [Head-to-head synthesis efficiency with alternative fluorinated reagents]. BenchChem, [2026]. [Online PDF]. Available at: [<https://www.benchchem.com/product/b1421929/docs#head-to-head-synthesis-efficiency-with-alternative-fluorinated-reagents>]

---

### Disclaimer & Data Validity:

The information provided in this document is for Research Use Only (RUO) and is strictly not intended for diagnostic or therapeutic procedures. While BenchChem strives to provide accurate protocols, we make no warranties, express or implied, regarding the fitness of this product for every specific experimental setup.

**Technical Support:** The protocols provided are for reference purposes. Unsure if this reagent suits your experiment?

**Need Industrial/Bulk Grade?** [Request Custom Synthesis Quote](#)

## BenchChem

Our mission is to be the trusted global source of essential and advanced chemicals, empowering scientists and researchers to drive progress in science and industry.

### Contact

Address: 3281 E Guasti Rd  
Ontario, CA 91761, United States  
Phone: (601) 213-4426  
Email: [info@benchchem.com](mailto:info@benchchem.com)

[Contact our Ph.D. Support Team for a compatibility check](#)