

# Technical Support Center: Optimizing Catalyst Selection for Pyrimidine Ring Formation

**Author:** BenchChem Technical Support Team. **Date:** May 2026

## Compound of Interest

Compound Name: *2-Methylsulfonyl-5-bromopyrimidine-4-carboxylic acid*

CAS No.: 30321-94-9

Cat. No.: B1587656

[Get Quote](#)

Prepared by: Gemini, Senior Application Scientist

Welcome to the technical support center for pyrimidine synthesis. This guide is designed for researchers, scientists, and drug development professionals to navigate the complexities of catalyst selection and reaction optimization. Pyrimidine scaffolds are fundamental to medicinal chemistry, forming the core of numerous therapeutic agents and nucleic acids.[1] The efficiency of their synthesis is therefore a critical parameter in drug discovery and development.

This resource provides field-proven insights in a direct question-and-answer format, addressing specific experimental challenges with an emphasis on the causal relationships between catalyst choice, reaction conditions, and outcomes.

## Troubleshooting Guide: Common Experimental Issues

This section addresses specific problems you may encounter during pyrimidine synthesis, offering systematic approaches to diagnose and resolve them.

## Q1: My reaction shows very low or no conversion to the desired pyrimidine product. What are the likely causes and solutions?

A1: Low conversion is a frequent issue stemming from several factors, including catalyst inefficiency, suboptimal reaction conditions, or problems with the starting materials.<sup>[2]</sup> A systematic approach is crucial for diagnosis.

Troubleshooting Steps:

- Verify Catalyst Activity:
  - Deactivation: Ensure your catalyst is active. Reusable catalysts may require regeneration after a certain number of cycles.<sup>[2]</sup> For transition metal catalysts, particularly palladium, ensure the active Pd(0) state is achieved and maintained; air or moisture sensitivity can lead to deactivation.<sup>[3][4]</sup> Conduct reactions under an inert atmosphere (e.g., Nitrogen or Argon).<sup>[3]</sup>
  - Poisoning: Impurities in reactants or solvents, such as sulfur or certain nitrogen compounds, can act as poisons for many transition metal catalysts.<sup>[3]</sup> Purify all reagents and use high-purity, anhydrous solvents.
  - Loading: The catalyst loading may be insufficient. While typical loadings for metal catalysts range from 1-10 mol%, it's essential to screen different concentrations to find the optimum for your specific substrates.<sup>[3]</sup>
- Optimize Reaction Conditions:
  - Temperature & Time: The reaction may require more thermal energy or a longer duration to overcome its activation energy.<sup>[5]</sup> Monitor the reaction's progress closely using Thin Layer Chromatography (TLC) or LC-MS to determine the optimal reaction time and prevent potential product degradation from prolonged heating.<sup>[2]</sup>
  - Solvent Choice: The solvent's polarity can significantly impact reaction rates and yields.<sup>[5]</sup> While ethanol is common for reactions like the Biginelli or Pinner synthesis, exploring

other solvents like acetonitrile, DMF, or even solvent-free conditions can lead to improved outcomes.[1][5]

- Check Reagent Purity and Stoichiometry:
  - Purity: Impurities in starting materials (e.g., aldehydes,  $\beta$ -ketoesters, amidines, urea) can inhibit the catalyst or lead to unwanted side reactions.[6] Ensure all reagents are of high purity.
  - Steric Hindrance: Bulky substituents on your starting materials may slow the reaction. In such cases, a more active catalyst or higher reaction temperatures might be necessary.[5]

## Troubleshooting Workflow for Low Conversion

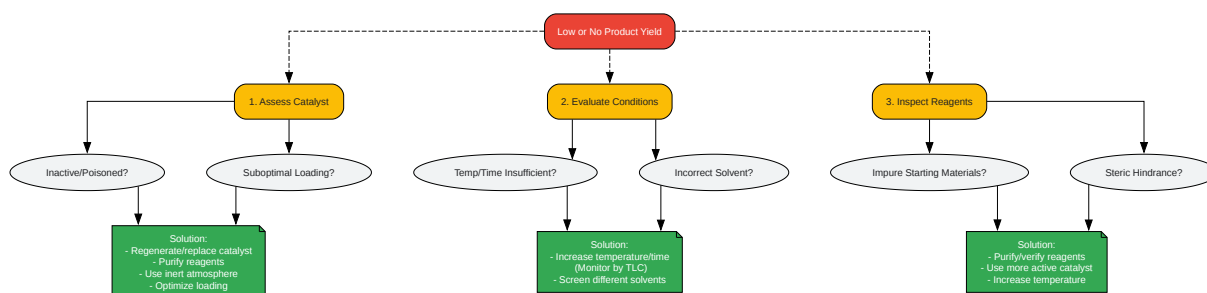

[Click to download full resolution via product page](#)

Caption: A logical workflow to diagnose and solve low conversion issues.

**Q2: I'm observing significant side product formation. How can I improve the selectivity of my reaction?**

A2: Side product formation is common, especially in multicomponent reactions. The key is to understand the competing reaction pathways and adjust conditions to favor the desired one.

#### Common Side Reactions & Prevention Strategies:

- Hantzsch Dihydropyridine in Biginelli Reactions: This is a frequent fluorescent byproduct that occurs when two equivalents of the  $\beta$ -ketoester react with the aldehyde and ammonia (from urea decomposition).[6]
  - Temperature Control: This side reaction is favored at higher temperatures. Lowering the reaction temperature can significantly increase selectivity for the desired dihydropyrimidinone.[6]
  - Catalyst Choice: Certain Lewis acids may preferentially promote the Biginelli pathway over the Hantzsch pathway. Screening different acid catalysts is recommended.[6]
  - Order of Addition: Adding the urea last to the reaction mixture can sometimes minimize its decomposition.[6]
- Knoevenagel Condensation & Michael Adducts: In some cases, the initial condensation between the aldehyde and the 1,3-dicarbonyl compound can be a competing pathway, or other intermediates can form non-cyclized adducts.[3]
  - Adjust Stoichiometry: Using a slight excess of the urea or amidine component can sometimes suppress the formation of these side products by pushing the equilibrium towards the desired cyclization.[3]
  - Catalyst Selection: The catalyst plays a crucial role in orchestrating the sequence of bond formations. A well-chosen catalyst facilitates the complete cyclization cascade.
- Homocoupling in Cross-Coupling Reactions: In Suzuki couplings to form functionalized pyrimidines, homocoupling of the boronic acid is a common side reaction.
  - Minimize Oxygen: This is often exacerbated by oxygen, which can interfere with the Pd(0)/Pd(II) catalytic cycle. Ensure all solvents are thoroughly degassed and the reaction is run under a strict inert atmosphere.[7]

- Slow Addition: Slowly adding the boronic acid to the reaction mixture can minimize its concentration at any given time, reducing the rate of homocoupling.[4]

### Q3: My synthesis of an unsymmetrically substituted pyrimidine results in a mixture of regioisomers. How can I improve regioselectivity?

A3: Achieving high regioselectivity is a significant challenge when the reacting components are unsymmetrical. The choice of catalyst and reaction strategy is paramount.

Strategies for Controlling Regioselectivity:

- Catalyst-Controlled Synthesis: The ligand sphere and electronic properties of a metal catalyst can direct the reactants to combine in a specific orientation.
  - Iridium Catalysis: Iridium-catalyzed multicomponent synthesis from amidines and alcohols has demonstrated high regioselectivity, providing a powerful tool for constructing specific pyrimidine isomers.[3][8]
  - Copper Catalysis: Copper-catalyzed cycloadditions of alkynes with nitrogen-containing molecules like amidines are also effective for building the pyrimidine core, with selectivity often dictated by the catalyst and reaction conditions.[9]
- Substrate-Controlled Synthesis: Modify one of the starting materials to have a directing group or a significant difference in steric or electronic properties between its reactive sites, thereby favoring one cyclization pathway over another.
- Stepwise Synthesis: While one-pot multicomponent reactions are efficient, a more controlled, stepwise synthesis may be necessary to achieve the desired regioselectivity, where intermediates are isolated before the final cyclization step.

## Frequently Asked Questions (FAQs)

### Q1: What are the most common types of catalysts used for pyrimidine synthesis?

A1: A wide array of catalysts are employed, and they can be broadly categorized as follows:

- **Metal-Based Catalysts:** These are highly effective and widely used. They include salts and complexes of palladium, copper, iridium, nickel, zinc, and iron.[3][10] They are crucial for modern synthetic strategies, including multicomponent reactions and cross-coupling.[9][11]
- **Acid/Base Catalysts:** Simple Brønsted acids (e.g., HCl, p-TSA) and Lewis acids (e.g., Yb(OTf)<sub>3</sub>, InCl<sub>3</sub>, ZnCl<sub>2</sub>) are classically used to catalyze condensation reactions like the Biginelli reaction.[5][12][13] Bases are also used to promote certain cyclizations.[9]
- **Organocatalysts:** These are metal-free organic molecules that can catalyze reactions. Proline and its derivatives are common examples used in pyrimidine synthesis.[14] They are often considered a "greener" alternative to metal catalysts.
- **Biocatalysts:** Enzymes can be used to construct the pyrimidine ring with high efficiency and selectivity under mild, environmentally friendly conditions.[10] This approach is a cornerstone of green chemistry.

## Q2: How do I choose between a metal-based catalyst and an organocatalyst?

A2: The choice depends on the specific transformation, substrate scope, and desired reaction conditions.

| Catalyst Type  | Advantages   | Disadvantages   | Best For...  |
|----------------|--|---|--|
| Metal-Based    | High catalytic activity, versatile, enables a wide range of reactions (e.g., cross-coupling).[11]                          | Often sensitive to air and moisture, potential for heavy metal contamination in the final product, can be expensive.[3] | Complex multicomponent reactions, cross-coupling to functionalize the pyrimidine ring, achieving high regioselectivity.[3][15]           |
| Organocatalyst | Generally stable to air and moisture, lower toxicity, environmentally benign, can provide high enantioselectivity.[14][16] | May require higher catalyst loading, might have a more limited substrate scope compared to some metal catalysts.        | Classic condensation reactions (e.g., Biginelli-type), asymmetric synthesis, reactions where metal contamination is a major concern.[14] |

### Q3: Are there "green" or sustainable catalyst options for pyrimidine synthesis?

A3: Yes, the development of sustainable synthetic methods is a major focus of modern chemistry. Key green approaches include:

- Use of Recyclable Catalysts: Solid-supported catalysts or magnetic nanocatalysts can be easily recovered from the reaction mixture and reused, reducing waste and cost.[12]
- Biocatalysis: Using enzymes as catalysts operates in aqueous media under mild conditions.[10]
- Solvent-Free Reactions: Performing reactions without a solvent (or using water as a "green" solvent) significantly reduces environmental impact.[17] Microwave-assisted solvent-free Biginelli reactions are a prime example.[13]
- Use of Benign Catalysts: Employing non-toxic and readily available catalysts, such as certain organocatalysts or earth-abundant metal catalysts (e.g., iron), is preferred over rare or toxic

heavy metals.[8][10]

## Experimental Protocols & Data

### Protocol 1: General Procedure for the Acid-Catalyzed Biginelli Reaction

This classical one-pot, three-component reaction is widely used for synthesizing dihydropyrimidinones (DHPMs).[1]

Materials:

- Aldehyde (1.0 eq)
- $\beta$ -Ketoester (1.0 eq)
- Urea (1.5 eq)
- Catalyst (e.g., HCl, Yb(OTf)<sub>3</sub>, 5-10 mol%)
- Ethanol

Procedure:

- To a round-bottom flask, add the aldehyde,  $\beta$ -ketoester, urea, and ethanol.
- Add the acid catalyst to the mixture.
- Fit the flask with a reflux condenser and heat the mixture to reflux (approx. 78 °C for ethanol) with stirring.
- Monitor the reaction progress by TLC (e.g., using a 7:3 hexane:ethyl acetate eluent).[2]
- Upon completion (typically 2-8 hours), cool the reaction mixture to room temperature.
- A solid precipitate will often form. Collect the solid by filtration.
- Wash the solid with cold ethanol to remove unreacted starting materials.[2]

- Recrystallize the crude product from ethanol to yield the pure dihydropyrimidinone.

## Biginelli Reaction Mechanism

The reaction proceeds through a key iminium ion intermediate.

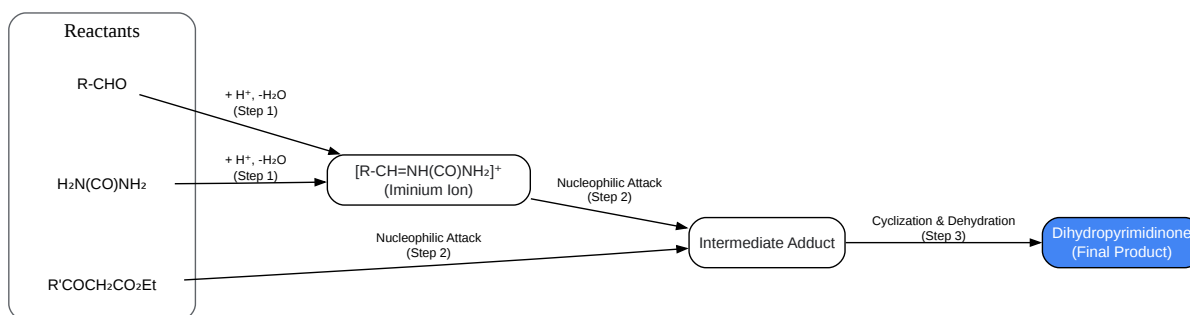

[Click to download full resolution via product page](#)

Caption: The acid-catalyzed mechanism of the Biginelli condensation.[13]

## Protocol 2: General Procedure for the Pinner Synthesis of Pyrimidines

The Pinner synthesis involves the condensation of a 1,3-dicarbonyl compound with an amidine.

[1]

Materials:

- 1,3-Dicarbonyl compound (1.0 eq)
- Amidine hydrochloride (1.2 eq)
- Base (e.g., Sodium Ethoxide)

- Ethanol

Procedure:

- Prepare a solution of the base (e.g., sodium ethoxide) in absolute ethanol in a round-bottom flask under an inert atmosphere.
- Add the 1,3-dicarbonyl compound to the solution and stir.
- Add the amidine hydrochloride portion-wise to the reaction mixture.
- Heat the mixture to reflux and stir until the reaction is complete, as monitored by TLC.
- After completion, cool the mixture to room temperature and neutralize with a suitable acid (e.g., acetic acid).
- Remove the solvent under reduced pressure.
- The crude residue can be purified by recrystallization or column chromatography to yield the pure pyrimidine.

## References

- N/A. Pyrimidine Synthesis and Degradation - Biochemistry. [\[Link\]](#)
- ResearchGate. Optimization of Reaction Conditions for the Synthesis of O-Alkylated Pyrimidine 4a a. [\[Link\]](#)
- MDPI. Catalyzed Methods to Synthesize Pyrimidine and Related Heterocyclic Compounds. [\[Link\]](#)
- PubMed. Sustainable Green Synthesis of Pyrimidine Derivatives: Review on Multicomponent Synthesis, Catalysts and Techniques. [\[Link\]](#)
- N/A. Synthesis of Pyrimidine-Based Analogues: A Comprehensive Review. [\[Link\]](#)
- Fiveable. Pyrimidine biosynthesis and catabolism | Biological Chemistry II Class Notes. [\[Link\]](#)

- N/A. Synthesis of Pyrimidine-Based Analogues: A Comprehensive Review. [[Link](#)]
- PubMed. Transition-Metal Catalyzed Synthesis of Pyrimidines: Recent Advances, Mechanism, Scope and Future Perspectives. [[Link](#)]
- Organic Chemistry Portal. Synthesis of pyrimidine. [[Link](#)]
- ResearchGate. Optimization of the reaction conditions. [a] | Download Table. [[Link](#)]
- PubMed Central. Importance of Hybrid Catalysts toward the Synthesis of 5H-Pyrano[2,3-d]pyrimidine-2-ones/2,4-diones (Thiones). [[Link](#)]
- Microbe Notes. De novo pyrimidine synthesis steps, pathways, uses. [[Link](#)]
- ACS Omega. Importance of Hybrid Catalysts toward the Synthesis of 5H-Pyrano[2,3-d]pyrimidine-2-ones/2,4-diones (Thiones). [[Link](#)]
- ResearchGate. Scheme 1: Strategies of pyrimidine synthesis | Download Scientific Diagram. [[Link](#)]
- Wikipedia. Pyrimidine. [[Link](#)]
- RSC Publishing. Acid-catalysed ring-cleavage of some pyrimidine derivatives. [[Link](#)]
- Atlas: School AI Assistant. Biginelli Reaction Experiment Analysis Guide. [[Link](#)]
- ResearchGate. Palladium-Catalyzed Synthesis of Pyrimidines | Request PDF. [[Link](#)]
- Reddit. Diagnosing issues with a failed Suzuki coupling?. [[Link](#)]
- Journal of the American Chemical Society. A Sustainable Multicomponent Pyrimidine Synthesis. [[Link](#)]
- ResearchGate. How can I solve my problem with Suzuki coupling?. [[Link](#)]
- PubMed Central. Bypassing the Limitations of Directed C–H Functionalizations of Heterocycles. [[Link](#)]

- N/A. 10. Pyrimidines. [[Link](#)]
- Reddit. How to Synthesis purine and pyrimidine bases. [[Link](#)]
- Growing Science. Current Chemistry Letters Synthesis, reactions, and applications of pyrimidine derivatives. [[Link](#)]
- Organic Chemistry Portal. Biginelli Reaction. [[Link](#)]
- YouTube. Biginelli Reaction. [[Link](#)]

### Need Custom Synthesis?

BenchChem offers custom synthesis for rare earth carbides and specific isotopic labeling.

Email: [info@benchchem.com](mailto:info@benchchem.com) or [Request Quote Online](#).

## Sources

- 1. [benchchem.com](https://benchchem.com) [[benchchem.com](https://benchchem.com)]
- 2. [benchchem.com](https://benchchem.com) [[benchchem.com](https://benchchem.com)]
- 3. [benchchem.com](https://benchchem.com) [[benchchem.com](https://benchchem.com)]
- 4. [benchchem.com](https://benchchem.com) [[benchchem.com](https://benchchem.com)]
- 5. [benchchem.com](https://benchchem.com) [[benchchem.com](https://benchchem.com)]
- 6. [benchchem.com](https://benchchem.com) [[benchchem.com](https://benchchem.com)]
- 7. [benchchem.com](https://benchchem.com) [[benchchem.com](https://benchchem.com)]
- 8. Pyrimidine synthesis [[organic-chemistry.org](https://organic-chemistry.org)]
- 9. [mdpi.com](https://mdpi.com) [[mdpi.com](https://mdpi.com)]
- 10. [bocsci.com](https://bocsci.com) [[bocsci.com](https://bocsci.com)]
- 11. Transition-Metal Catalyzed Synthesis of Pyrimidines: Recent Advances, Mechanism, Scope and Future Perspectives - PubMed [[pubmed.ncbi.nlm.nih.gov](https://pubmed.ncbi.nlm.nih.gov)]
- 12. [jchemrev.com](https://jchemrev.com) [[jchemrev.com](https://jchemrev.com)]
- 13. Biginelli Reaction [[organic-chemistry.org](https://organic-chemistry.org)]

- [14. Importance of Hybrid Catalysts toward the Synthesis of 5H-Pyrano\[2,3-d\]pyrimidine-2-ones/2,4-diones \(Thiones\) - PMC \[pmc.ncbi.nlm.nih.gov\]](#)
- [15. benchchem.com \[benchchem.com\]](#)
- [16. pubs.acs.org \[pubs.acs.org\]](#)
- [17. Sustainable Green Synthesis of Pyrimidine Derivatives: Review on Multicomponent Synthesis, Catalysts and Techniques - PubMed \[pubmed.ncbi.nlm.nih.gov\]](#)
- To cite this document: BenchChem. [Technical Support Center: Optimizing Catalyst Selection for Pyrimidine Ring Formation]. BenchChem, [2026]. [Online PDF]. Available at: [\[https://www.benchchem.com/product/b1587656/docs#technical-support-center-optimizing-catalyst-selection-for-pyrimidine-ring-formation\]](https://www.benchchem.com/product/b1587656/docs#technical-support-center-optimizing-catalyst-selection-for-pyrimidine-ring-formation)

---

### Disclaimer & Data Validity:

The information provided in this document is for Research Use Only (RUO) and is strictly not intended for diagnostic or therapeutic procedures. While BenchChem strives to provide accurate protocols, we make no warranties, express or implied, regarding the fitness of this product for every specific experimental setup.

**Technical Support:** The protocols provided are for reference purposes. Unsure if this reagent suits your experiment?

**Need Industrial/Bulk Grade?** [Request Custom Synthesis Quote](#)

## BenchChem

Our mission is to be the trusted global source of essential and advanced chemicals, empowering scientists and researchers to drive progress in science and industry.

### Contact

Address: 3281 E Guasti Rd  
Ontario, CA 91761, United States  
Phone: (601) 213-4426  
Email: [info@benchchem.com](mailto:info@benchchem.com)

Contact our Ph.D. Support Team for a compatibility check