

Technical Guide: Mass Spectrometric Characterization of 2,5-Dimethoxybenzyl Alcohol

Author: BenchChem Technical Support Team. **Date:** May 2026

Compound of Interest

Compound Name: 2,5-Dimethoxybenzyl alcohol

CAS No.: 33524-31-1

Cat. No.: B142674

[Get Quote](#)

Executive Summary

This technical guide provides a comprehensive analysis of the mass spectrometric behavior of **2,5-Dimethoxybenzyl alcohol** (2,5-DMBA). As a critical intermediate in the synthesis of psychoactive phenethylamines (e.g., the 2C-x series) and a key metabolite in forensic toxicology, accurate characterization of 2,5-DMBA is essential. This document details the electron ionization (EI) fragmentation pathways, electrospray ionization (ESI) mechanisms, and protocols for differentiating 2,5-DMBA from its positional isomers (e.g., 3,4-dimethoxybenzyl alcohol).

Chemical Identity & Physicochemical Context

Before interpreting spectral data, the structural constraints governing fragmentation must be understood.^[1] The ortho relationship between the methoxy group at position 2 and the hydroxymethyl group is the primary driver of specific fragmentation rearrangements.

Property	Value
IUPAC Name	(2,5-dimethoxyphenyl)methanol
CAS Number	33524-31-1
Molecular Formula	
Exact Mass	168.0786 Da
Key Functional Groups	Primary Alcohol (Benzylic), Methoxy Ether (x2)
Structural Feature	Ortho-effect capability (C2-OMe vs. C1-CH2OH)

Instrumentation & Methodology

To ensure reproducibility, the following instrument parameters are recommended for the generation of reference-quality spectra.

Gas Chromatography-Mass Spectrometry (GC-MS)[1]

- Ionization: Electron Ionization (EI) at 70 eV.[1]
- Source Temperature: 230 °C (Prevent thermal degradation of the alcohol).
- Column: 5% Phenyl-methylpolysiloxane (e.g., DB-5ms, HP-5ms).[1]
- Inlet: Splitless mode recommended for trace impurity analysis; 250 °C.
- Carrier Gas: Helium, constant flow 1.0 mL/min.[1]

Liquid Chromatography-Mass Spectrometry (LC-MS)[1]

- Ionization: Electrospray Ionization (ESI) in Positive Mode ().
- Mobile Phase:
 - A: Water + 0.1% Formic Acid.[1]

- B: Acetonitrile + 0.1% Formic Acid.[1]
- Gradient: 5% B to 95% B over 10 minutes (C18 column).
- Adduct Formation: Expect

(m/z 169) and

(m/z 191).[1]

may form if ammonium buffers are used.[1]

EI Fragmentation Mechanics (The Core)

The EI mass spectrum of 2,5-DMBA is characterized by a stable molecular ion and a distinct fragmentation series driven by the methoxy substituents. Unlike simple aliphatic alcohols, the aromatic ring stabilizes the radical cation, resulting in a prominent parent peak.

Key Diagnostic Ions

m/z	Identity	Relative Abundance*	Mechanistic Origin
168		100% (Base Peak)	Stable molecular ion. [1]
153		~17%	Loss of methyl radical from a methoxy group. [1]
139		~16%	Loss of formyl radical (benzylic alcohol cleavage).[1]
137		~9%	Direct loss of methoxy radical.[1]
125		~37%	Sequential loss: .
121		~6%	Dimethoxyphenyl cation variant (complex rearrangement).[1]

*Abundances are approximate and instrument-dependent.[1]

Fragmentation Pathway Analysis

The fragmentation logic follows two primary channels:

- Methoxy-Driven Channel: The radical cation localizes on the methoxy oxygen, leading to -cleavage (loss of) to form a quinoid-like cation (m/z 153). This ion subsequently eliminates carbon monoxide (CO) to yield m/z 125.[1] This 168
153

125 sequence is highly diagnostic for dimethoxybenzenes.[1]

- Benzylic Alcohol Channel: The hydroxymethyl group undergoes cleavage, losing a formyl radical (, 29 Da) to form m/z 139, or losing the hydroxyl radical (, 17 Da) to form the benzyl cation (m/z 151).

Visualization of Fragmentation Pathways

The following diagram illustrates the causal relationships between the molecular ion and its primary fragments.

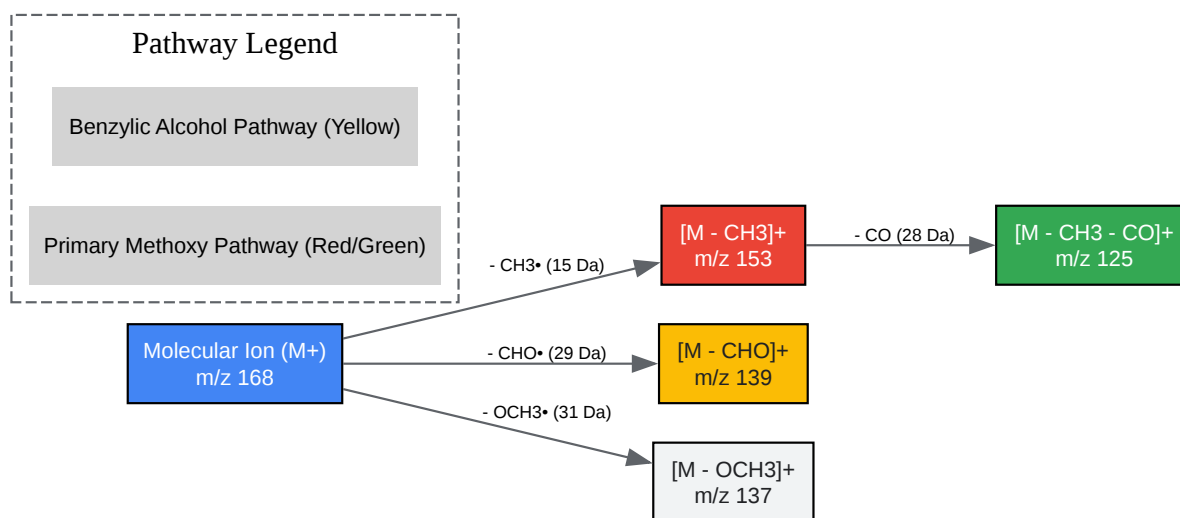

[Click to download full resolution via product page](#)

Figure 1: EI Fragmentation pathway of **2,5-Dimethoxybenzyl alcohol** showing the critical transition from m/z 168 to m/z 125 via m/z 153.

Differentiation of Isomers (2,5- vs 3,4- vs 2,3-)

Distinguishing 2,5-DMBA from its isomers (e.g., 3,4-dimethoxybenzyl alcohol) is a common challenge in forensic and synthetic chemistry.[1] Mass spectrometry alone can be ambiguous

due to identical molecular weights; however, the Ortho Effect provides a mechanism for differentiation.[1][2]

The Ortho Effect Mechanism

In 2,5-DMBA (and 2,3-DMBA), the methoxy group at the C2 position is ortho to the hydroxymethyl group. This proximity facilitates a specific hydrogen transfer mechanism that is sterically impossible for the 3,4-isomer.[1]

- 2,5- and 2,3-Isomers: Exhibit a higher abundance of (m/z 150) or (m/z 138) fragments compared to the 3,4-isomer due to the interaction between the hydroxyl hydrogen and the ether oxygen.
- 3,4-Isomer: Lacks the ortho-interaction.[1] Its fragmentation is dominated by simple benzylic cleavages without the facile loss of neutral small molecules via ring closure.[1]

Analytical Workflow for Isomer Identification

To definitively identify the 2,5-isomer, a combined approach using Retention Indices (RI) and diagnostic ion ratios is required.[3]

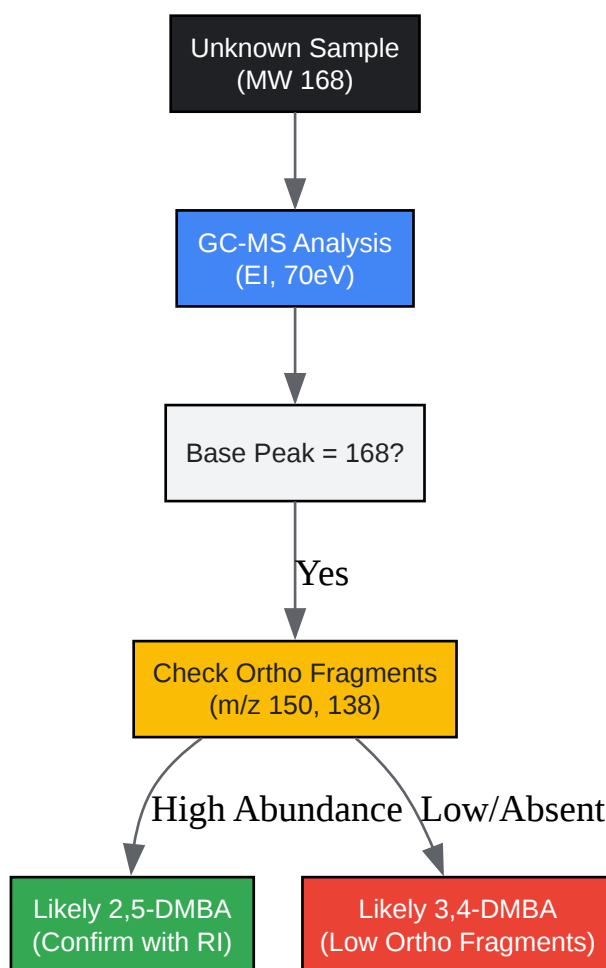

[Click to download full resolution via product page](#)

Figure 2: Decision tree for differentiating dimethoxybenzyl alcohol isomers based on spectral features.

Impurity Profiling in Drug Development

2,5-DMBA is a direct precursor to 2,5-dimethoxybenzaldehyde (via oxidation) or can be derived from it (via reduction).[1] In the synthesis of 2C-H or NBOMe derivatives, monitoring 2,5-DMBA levels is critical for yield optimization and purity assessment.

- Precursor Differentiation: 2,5-Dimethoxybenzaldehyde (MW 166) will show a molecular ion at m/z 166 and a base peak at m/z 165 (), easily distinguishing it from the alcohol (MW 168).

- Over-Reduction: If reducing the aldehyde to the methyl derivative (2,5-dimethoxytoluene, MW 152), the alcohol appears as an impurity at m/z 168.

References

- NIST Mass Spectrometry Data Center. (2023).[1] **2,5-Dimethoxybenzyl alcohol** Mass Spectrum. NIST Chemistry WebBook, SRD 69.[1][4] [Link\[1\]](#)
- ChemicalBook. (n.d.).[1] **2,5-Dimethoxybenzyl alcohol** Spectral Data. [Link](#)
- PubChem. (2025).[1] **2,5-Dimethoxybenzyl alcohol** Compound Summary. National Library of Medicine.[1] [Link\[1\]](#)
- Jackson, G. P., et al. (2019).[1] Differentiation of 2,5-dimethoxy-N-(N-methoxybenzyl)phenethylamine (NBOMe) isomers using GC retention indices and multivariate analysis. Forensic Chemistry. [Link\[1\]](#)
- Sigma-Aldrich. (2025).[1] Product Specification: **2,5-Dimethoxybenzyl alcohol**.[1][5][6] Merck KGaA.[1] [Link\[1\]\[6\]](#)

Need Custom Synthesis?

BenchChem offers custom synthesis for rare earth carbides and specific isotopic labeling.

Email: info@benchchem.com or [Request Quote Online](#).

Sources

- 1. 2,5-Dimethoxybenzyl alcohol | C₉H₁₂O₃ | CID 118495 - PubChem [pubchem.ncbi.nlm.nih.gov]
- 2. mdpi.com [mdpi.com]
- 3. glenjackson.faculty.wvu.edu [glenjackson.faculty.wvu.edu]
- 4. 2,3-Dimethoxybenzyl alcohol [webbook.nist.gov]
- 5. 2,5-DIMETHOXYBENZYL ALCOHOL(33524-31-1) 1H NMR spectrum [chemicalbook.com]
- 6. 2,5-二甲氧基苯甲醇 99% | Sigma-Aldrich [sigmaaldrich.com]

- To cite this document: BenchChem. [Technical Guide: Mass Spectrometric Characterization of 2,5-Dimethoxybenzyl Alcohol]. BenchChem, [2026]. [Online PDF]. Available at: [<https://www.benchchem.com/product/b142674/docs#technical-guide-mass-spectrometric-characterization-of-2-5-dimethoxybenzyl-alcohol>]

Disclaimer & Data Validity:

The information provided in this document is for Research Use Only (RUO) and is strictly not intended for diagnostic or therapeutic procedures. While BenchChem strives to provide accurate protocols, we make no warranties, express or implied, regarding the fitness of this product for every specific experimental setup.

Technical Support: The protocols provided are for reference purposes. Unsure if this reagent suits your experiment?

Need Industrial/Bulk Grade? [Request Custom Synthesis Quote](#)

BenchChem

Our mission is to be the trusted global source of essential and advanced chemicals, empowering scientists and researchers to drive progress in science and industry.

Contact

Address: 3281 E Guasti Rd
Ontario, CA 91761, United States
Phone: (601) 213-4426
Email: info@benchchem.com

[Contact our Ph.D. Support Team for a compatibility check](#)