

Cross-validation of different extraction methods for tributyltin

Author: BenchChem Technical Support Team. **Date:** May 2026

Compound of Interest

Compound Name: Tributyltin chloride-d27

CAS No.: 1257647-76-9

Cat. No.: B142046

[Get Quote](#)

An In-Depth Guide to the Cross-Validation of Tributyltin (TBT) Extraction Methods

For researchers, scientists, and professionals in drug development and environmental monitoring, the accurate quantification of tributyltin (TBT) is paramount. A potent biocide historically used in anti-fouling paints, TBT is a persistent and highly toxic environmental pollutant that bioaccumulates in aquatic organisms, posing significant risks to ecosystems and human health.[1][2][3] The critical first step in any analytical workflow for TBT is its efficient extraction from the sample matrix, a process fraught with challenges due to TBT's propensity to adsorb onto surfaces and its variable chemical forms.[2][4][5]

This guide provides a comprehensive cross-validation of prevalent TBT extraction methodologies. Moving beyond a simple listing of protocols, we will delve into the causality behind experimental choices, compare performance based on experimental data, and offer field-proven insights to help you select and validate the optimal method for your specific application, be it water, sediment, or biological tissue.

The Foundation: Core Principles of TBT Extraction and Analysis

Successful TBT analysis hinges on overcoming two primary obstacles: liberating the TBT cation from the sample matrix and rendering it suitable for instrumental analysis.

- **Extraction:** The core challenge lies in breaking the strong interactions between the polar TBT cation and the matrix. For solid samples like sediment and tissues, this often requires acidic conditions or the use of a complexing agent, such as tropolone, which forms a neutral, more easily extractable complex with TBT.[2][6][7]
- **Derivatization for GC Analysis:** Due to their low volatility, organotin compounds require a derivatization step to be analyzed by Gas Chromatography (GC).[8] This process converts the ionic TBT into a more volatile, thermally stable species. Common derivatizing agents include Grignard reagents (e.g., pentylmagnesium bromide) or, more frequently, sodium tetraethylborate (NaBEt_4), which ethylates the TBT cation.[6][7][9] It is crucial to note that methods employing High-Performance Liquid Chromatography (HPLC) often do not require this derivatization step.[8]

A self-validating and trustworthy protocol is essential. This is achieved through two key practices:

- **Use of Internal Standards:** An analogue compound, such as deuterated TBT (TBT-d27) or tripropyltin (TPT), should be added to the sample at the very beginning of the procedure.[7][10] This standard experiences the same potential losses as the native TBT during extraction and cleanup, allowing for accurate quantification and recovery calculation.
- **Analysis of Certified Reference Materials (CRMs):** The accuracy of the entire method must be verified by analyzing a CRM with a certified concentration of TBT in a similar matrix (e.g., coastal sediment or mussel tissue).[3][6][11] This validates the method's ability to deliver accurate results.

Comparative Analysis of Extraction Methodologies

The choice of extraction method is a critical decision dictated by the sample matrix, required sensitivity, available equipment, and considerations such as solvent consumption and sample

throughput. Here, we compare several leading techniques.

Liquid-Liquid Extraction (LLE)

LLE is a traditional, foundational technique based on partitioning the analyte between two immiscible liquid phases. For TBT, this typically involves extracting the analyte from an aqueous sample into an organic solvent.

Causality & Rationale: The efficiency of LLE is governed by the relative solubility of the TBT species in the aqueous and organic phases. Adjusting the pH of the aqueous phase can protonate or deprotonate the analyte, altering its solubility and improving the partition coefficient into the organic layer. While simple in principle, LLE can be laborious and prone to the formation of emulsions, especially with complex matrices.[\[12\]](#)

Experimental Protocol: LLE for Water Samples

- **Sample Preparation:** To a 500 mL water sample, add an internal standard (e.g., tripropyltin). Acidify the sample to pH ~2 with HCl.
- **Extraction:** Transfer the sample to a 1 L separatory funnel. Add 50 mL of a suitable organic solvent (e.g., n-hexane containing 0.03% w/v tropolone).
- **Partitioning:** Shake the funnel vigorously for 2-3 minutes, periodically venting to release pressure.
- **Phase Separation:** Allow the layers to separate completely. Drain the lower aqueous layer.
- **Collection:** Collect the upper organic layer. Repeat the extraction on the aqueous phase two more times with fresh solvent.
- **Drying & Concentration:** Combine the organic extracts and dry them by passing through anhydrous sodium sulfate. Concentrate the extract to a final volume of 1 mL under a gentle stream of nitrogen before derivatization and analysis.

Workflow Diagram: Liquid-Liquid Extraction (LLE)

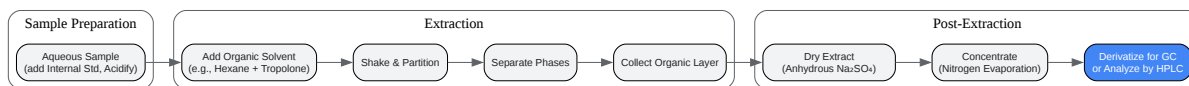

[Click to download full resolution via product page](#)

Caption: Workflow for Tributyltin LLE.

Solid-Phase Extraction (SPE)

SPE is a highly efficient and widely adopted technique for extracting and concentrating analytes from liquid samples. It involves passing the sample through a solid sorbent material that retains the analyte, which is later eluted with a small volume of solvent.

Causality & Rationale: The principle of SPE is based on the affinity of the analyte for the solid phase. For TBT, non-polar C18 (octadecyl) bonded silica is a common choice. The TBT cation is retained on the C18 sorbent through hydrophobic interactions. Interfering polar compounds pass through the cartridge with the sample matrix, providing effective cleanup. The retained TBT is then eluted with a strong organic solvent. This technique significantly reduces solvent consumption compared to LLE and is easily automated.[6][12][13]

Experimental Protocol: SPE for Water Samples

- **Cartridge Conditioning:** Condition a C18 SPE cartridge (e.g., 500 mg, 6 mL) by passing 5 mL of methanol followed by 5 mL of deionized water. Do not allow the cartridge to go dry.
- **Sample Loading:** Acidify the water sample (up to 1 L) to pH ~2 and add the internal standard. Pass the sample through the conditioned SPE cartridge at a flow rate of 8-10 mL/min.[6]
- **Washing:** Wash the cartridge with 5 mL of deionized water to remove any remaining polar impurities.
- **Drying:** Dry the cartridge by applying a vacuum for 10-15 minutes.

- Elution: Elute the TBT from the cartridge with 5-10 mL of a suitable solvent, such as toluene or acetone/toluene mixture, into a collection tube.[6][10]
- Concentration: Concentrate the eluate to 1 mL under a gentle stream of nitrogen for subsequent analysis.

Workflow Diagram: Solid-Phase Extraction (SPE)

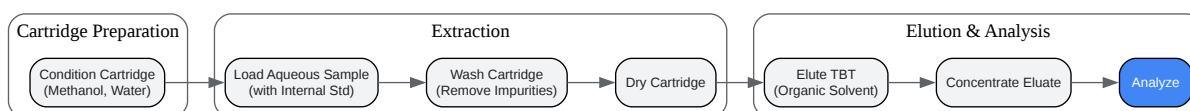

[Click to download full resolution via product page](#)

Caption: General workflow for Solid-Phase Extraction.

Advanced SPE-based Techniques:

- Solid-Phase Microextraction (SPME): Utilizes a coated fiber to adsorb analytes directly from the sample. It is a solvent-less technique that combines extraction and concentration into a single step.[5][14]
- Stir Bar Sorptive Extraction (SBSE): Employs a magnetic stir bar coated with a sorptive phase (e.g., polydimethylsiloxane). The stir bar is placed in the sample, and after a set time, it is removed, dried, and the analytes are thermally desorbed into a GC. SBSE offers very high sensitivity and is excellent for ultra-trace analysis.[15][16]

Ultrasound-Assisted Extraction (UAE) or Sonication

UAE uses high-frequency sound waves to create cavitation bubbles in the extraction solvent. The collapse of these bubbles near the surface of the solid matrix generates localized high pressure and temperature, disrupting cell walls and enhancing mass transfer of the analyte into the solvent.

Causality & Rationale: This method is particularly effective for solid matrices like sediments and biological tissues.[17] The mechanical effects of cavitation facilitate solvent penetration into the matrix pores and break the analyte-matrix bonds, significantly accelerating the extraction process compared to simple shaking or maceration.

Experimental Protocol: UAE for Sediment Samples

- **Sample Preparation:** Weigh approximately 2 g of dried sediment into a centrifuge tube. Add the internal standard.
- **Solvent Addition:** Add 10 mL of an appropriate extraction solvent. For sediments, a mixture of acetic acid and methanol is often effective.[6][17]
- **Sonication:** Place the tube in an ultrasonic bath or use an ultrasonic probe. Sonicate for 30 minutes.[6][17]
- **Separation:** Centrifuge the sample to separate the solid material from the solvent extract.
- **Collection:** Carefully pipette the supernatant (the extract) into a clean vial.
- **Cleanup:** The extract may require a cleanup step (e.g., passing through a silica gel column) before derivatization and analysis.[2]

Workflow Diagram: Ultrasound-Assisted Extraction (UAE)

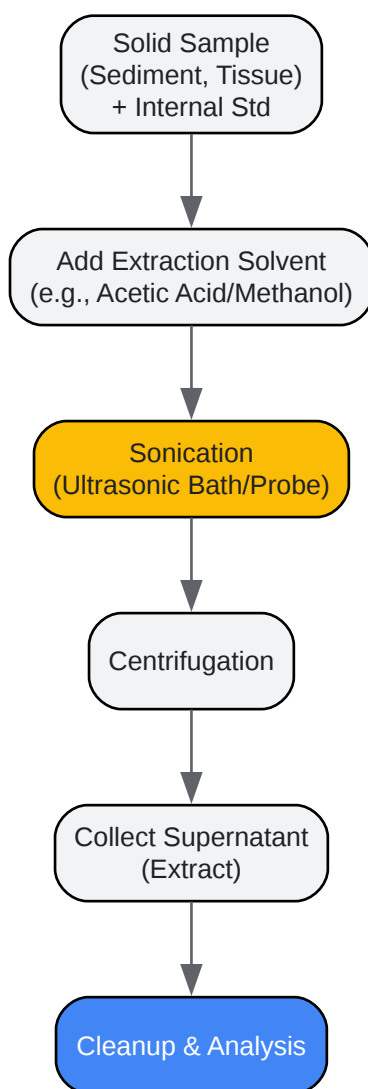

[Click to download full resolution via product page](#)

Caption: Workflow for Ultrasound-Assisted Extraction.

Microwave-Assisted Extraction (MAE)

MAE utilizes microwave energy to heat the extraction solvent directly. The rapid, localized heating of the solvent within the sample matrix creates high pressure, which ruptures the matrix structure and accelerates the desorption of the analyte into the solvent.

Causality & Rationale: This technique offers a dramatic reduction in extraction time (often to a few minutes) and solvent volume compared to traditional methods like Soxhlet.[18][19] The choice of solvent is critical; polar solvents absorb microwave energy more efficiently. MAE is highly effective for extracting organotins from various solid samples, including fortified flour.[18]

Experimental Protocol: MAE for Biological Tissues

- **Sample Preparation:** Place 0.5 g of homogenized tissue into a microwave extraction vessel. Add the internal standard.
- **Solvent Addition:** Add 20 mL of an extraction solvent mixture (e.g., acetic acid-hexane).[18]
- **Extraction:** Seal the vessel and place it in the microwave extraction system. Apply microwave energy (e.g., ramp to 100°C and hold for 3-5 minutes).[18]
- **Cooling & Filtration:** Allow the vessel to cool to room temperature. Filter the extract to remove solid particles.
- **Concentration:** Concentrate the extract as needed before analysis.

Workflow Diagram: Microwave-Assisted Extraction (MAE)

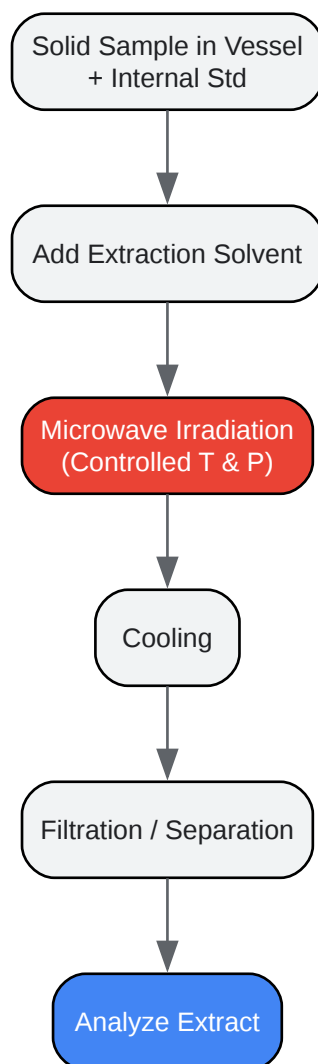

[Click to download full resolution via product page](#)

Caption: Workflow for Microwave-Assisted Extraction.

Pressurized Solvent Extraction (PSE)

Also known as Pressurized Liquid Extraction (PLE), this automated technique uses high temperature and pressure to maintain the solvent in its liquid state well above its atmospheric boiling point.

Causality & Rationale: The elevated temperature increases the solubility and diffusion rate of the analyte, while the high pressure forces the solvent into the matrix pores. This combination results in highly efficient and rapid extractions with reduced solvent consumption. A study

successfully applied PSE combined with LC-MS/MS for the determination of TBT in marine sediments.[20][21]

Experimental Protocol: PSE for Sediments

- Cell Preparation: Mix ~1 g of the sediment sample with a dispersing agent (e.g., diatomaceous earth) and pack it into an extraction cell.
- Extraction: Place the cell in the automated PSE system. The system will heat the cell (e.g., to 100°C) and pump the extraction solvent (e.g., hexane with tropolone) through the cell at high pressure (e.g., 1500 psi).[21]
- Collection: The extract is automatically collected in a vial. The system can perform multiple extraction cycles.
- Purging: After the extraction, the cell is purged with nitrogen gas to collect the remaining solvent.
- Analysis: The collected extract is then ready for cleanup or direct analysis.

Workflow Diagram: Pressurized Solvent Extraction (PSE)

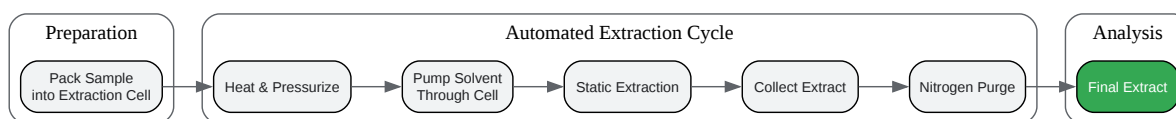

[Click to download full resolution via product page](#)

Caption: Automated workflow for Pressurized Solvent Extraction.

Quantitative Performance Cross-Validation

The following table summarizes experimental data from various studies to provide an objective comparison of the described methods. Note that performance metrics are highly dependent on the specific matrix, instrumentation, and laboratory conditions.

Extraction Method	Applicable Matrix	Typical Recovery (%)	Achieved LOD/LOQ	Processing Time	Solvent Use	Key Advantages
LLE	Water, Simple Liquids	60-80%	ng/L to µg/L range	Long (30-60 min/sample)	High	Low cost, simple equipment
SPE	Water (Surface, Sea, Drinking)	65-104% [11][12]	0.04 - 0.7 ng/L (LOD) [4]	Moderate (15-30 min/sample)	Low	High concentration factor, good cleanup, easily automated[6]
SBSE	Water	92-102% [15]	0.8 ng/L (LOD), 2.5 ng/L (LOQ) [15]	Long (equilibration)	Very Low	Extremely high sensitivity, minimal solvent use[16]
UAE (Sonication)	Sediment, Tissues	65-90%	µg/kg range	Fast (15-30 min/sample)	Moderate	Effective for solid matrices, simple setup[6][17]
MAE	Tissues, Sediment, Food	88-101% [18]	µg/kg range	Very Fast (3-15 min/sample)	Low	High speed, reduced solvent use, high efficiency[18][19]

PSE	Sediment, Tissues	>80% [21]	1.25 ng Sn/g (LOD) [20]	Fast (automated)	Low- Moderate	Automated, high throughput, efficient for difficult matrices [20]
-----	----------------------	---------------------------	---	-------------------------	------------------	--

Conclusion and Expert Recommendations

There is no single "best" method for TBT extraction; the optimal choice is a function of the analytical objective.

- For routine monitoring of TBT in water samples, Solid-Phase Extraction (SPE) offers the best balance of recovery, cleanup, and throughput. It is a robust and well-validated technique that effectively concentrates the analyte from large volumes.[\[6\]](#)
- For achieving the lowest possible detection limits in water, as required by stringent regulations, Stir Bar Sorptive Extraction (SBSE) coupled with a highly sensitive detector is the superior choice due to its exceptional pre-concentration capability.[\[15\]](#)[\[16\]](#)
- For complex solid matrices like sediment and biological tissues, more aggressive, energy-assisted methods are necessary. Microwave-Assisted Extraction (MAE) stands out for its remarkable speed and efficiency, while Pressurized Solvent Extraction (PSE) offers excellent performance in a high-throughput, automated format.[\[18\]](#)[\[20\]](#) Ultrasound-Assisted Extraction (UAE) remains a viable and cost-effective alternative.[\[17\]](#)

Ultimately, regardless of the method chosen, rigorous validation using internal standards and certified reference materials is non-negotiable. This practice ensures the trustworthiness of the data and provides the authoritative grounding required for confident decision-making in both research and regulatory contexts.

References

- Okoro, H. K., et al. (2012). Development of an Analytical Method for Determining Tributyltin and Triphenyltin in Seawater, Sediment, and Mussel Samples Using GC-FPD and GC-MS – TOF. Polish Journal of Environmental Studies, 21(6), 1743-1753.

- Okoro, H.K., et al. (2012). Development of an Analytical Method for Determining Tributyltin and Triphenyltin in Seawater, Sediment, and Mussel Samples Using GC-FPD and GC-MS – TOF. Polish Journal of Environmental Studies.
- BenchChem. (2025). Application Note and Protocol for Solid-Phase Extraction of Tributyltin Hydroxide from Tissue Samples. BenchChem.
- NMKL. (2023). New method: NMKL 205. TRACE ELEMENTS SPECIES – Tributyltin (TBT). Determination in seafood by isotope dilution GC-ICP-MS after acid extraction and derivatization. NMKL.org. Available at: [\[Link\]](#)
- Stark, A., et al. (2014). Determination of tributyltin in marine sediment and waters by pressurised solvent extraction and liquid chromatography-tandem mass spectrometry. Analytical and Bioanalytical Chemistry, 406(11), 2697-2704. Available at: [\[Link\]](#)
- Furdek Turk, M., et al. (2024). Spatial and temporal distribution of tributyltin in the coastal environment of the Croatian Adriatic (2016-2023): TBT remains a cause for concern. Frontiers in Marine Science. Available at: [\[Link\]](#)
- Inoue, Y., et al. (2000). Determination of tributyltin by automated in-tube solid-phase microextraction coupled with HPLC-ES-MS. Journal of Analytical Atomic Spectrometry, 15(10), 1329-1333. Available at: [\[Link\]](#)
- ARPAT. Analysis of Tributyltin (TBT). ARPAT. Available at: [\[Link\]](#)
- Agency for Toxic Substances and Disease Registry (ATSDR). (2005). Toxicological Profile for Tin and Tin Compounds. U.S. Department of Health and Human Services. Available at: [\[Link\]](#)
- Liscio, C., et al. (2009). Comparison of two analytical methods for the determination of organotin compounds in marine organisms. ResearchGate. Available at: [\[Link\]](#)
- Evans, O., & Caza, R. D. (1991). Liquid–solid extraction of tributyltin from marine samples. Analyst, 116(11), 1183-1186. Available at: [\[Link\]](#)
- Rodríguez-González, V., et al. (2013). Validation of a method for the determination of tributyltin in seawater by stir bar sorptive extraction-liquid chromatography tandem mass spectrometry. Journal of Chromatography A, 1272, 28-36. Available at: [\[Link\]](#)

- Inoue, Y., et al. (2000). Determination of tributyltin by automated in-tube solid-phase microextraction coupled with HPLC-ES-MS. *Journal of Analytical Atomic Spectrometry*. Available at: [\[Link\]](#)
- Valkirs, A. O., et al. (1985). Butyltin Compounds in Tissues. *DTIC*. Available at: [\[Link\]](#)
- British Columbia Ministry of Environment & Climate Change Strategy. (2021). Organotins in Sediment/Soil by GC with MS Detection. *Gov.bc.ca*. Available at: [\[Link\]](#)
- CYS. (2018). Water quality - Determination of tributyltin (TBT) in whole water samples - Method using solid phase extraction (SPE) with SPE disks and gas chromatography with triple quadrupole mass spectrometry. *CYS eShop*. Available at: [\[Link\]](#)
- Zaleska-Kycia, K., et al. (2015). Validation of analytical method for determination of tributyltin (TBT) in soils and bottom sediments. *Journal of Ecological Engineering*, 16(5), 153-161. Available at: [\[Link\]](#)
- ResearchGate. (2000). Determination of tributyltin by automated in tube solid phase microextraction coupled with HPLC ES MS. *ResearchGate*. Available at: [\[Link\]](#)
- Arain, S. A., et al. (2006). Development of an analytical method for organotin compounds in fortified flour samples using microwave-assisted extraction and normal-phase HPLC with UV detection. *Journal of Chromatography B*, 843(2), 268-274. Available at: [\[Link\]](#)
- David, F., et al. (2013). A new validated analytical method for the determination of tributyltin in water samples at the quantification level set by the European Union. *Analytica Chimica Acta*, 761, 107-113. Available at: [\[Link\]](#)
- Ebdon, L., et al. (1995). Determination of Total Tin and Tributyltin in Biological Tissues. *International Journal of Environmental Analytical Chemistry*, 53(1), 55-65. Available at: [\[Link\]](#)
- Stephenson, M. D., & Smith, D. R. (1988). Determination of tributyltin in tissues and sediments by graphite furnace atomic absorption spectrometry. *Analytical Chemistry*, 60(7), 696-698. Available at: [\[Link\]](#)
- Evans, O., & Caza, R. D. (1991). *Liquid-Solid Extraction of Tributyltin From Marine Samples*. RSC Publishing. Available at: [\[Link\]](#)

- Evans, O., & Caza, R. D. (1991). Liquid–solid extraction of tributyltin from marine samples. RSC Publishing. Available at: [\[Link\]](#)
- ResearchGate. (2014). Determination of tributyltin in marine sediment and waters by pressurised solvent extraction and liquid chromatography-tandem mass spectrometry. ResearchGate. Available at: [\[Link\]](#)
- U.S. Environmental Protection Agency. (2002). Method 8323: Determination of Organotins by Micro-Liquid Chromatography-Electrospray Ion Trap Mass Spectrometry. EPA.gov. Available at: [\[Link\]](#)
- Namieśnik, J., & Procyk, B. (2020). Microextraction Techniques Used in the Procedures for Determining Organomercury and Organotin Compounds in Environmental Samples. Molecules. Available at: [\[Link\]](#)
- ResearchGate. (2009). Derivatization methods for the determination of organotin compounds in environmental samples. ResearchGate. Available at: [\[Link\]](#)
- Hamza, M. F., et al. (2024). Optimization of Supercritical Fluid Extraction of Rare Earth Elements from Complex Ores Using a Tributyl Phosphate-Nitric Acid Adduct. ACS Sustainable Chemistry & Engineering. Available at: [\[Link\]](#)
- ALS Environmental. (2022). Determination of Selected Organotin Compounds in Liquids by GCMS. ALS Global. Available at: [\[Link\]](#)
- Al-zuaidy, M. H., et al. (2024). Supercritical Fluid Extraction: A Green and Sustainable Approach for the Isolation of High-Value Compounds from Natural Sources. Preprints.org. Available at: [\[Link\]](#)
- MDPI. (2024). Supercritical Fluid Extraction—A Sustainable and Selective Alternative for Tannin Recovery from Biomass Resources. MDPI. Available at: [\[Link\]](#)
- Sami-Sabinsa Group. (2008). Super Critical Fluid Extraction - The green manufacturing process. Sami-Sabinsa Group. Available at: [\[Link\]](#)
- Wikipedia. (n.d.). Supercritical fluid extraction. Wikipedia. Available at: [\[Link\]](#)

- ECOFUNCO Project. (2021). Microwave and ultrasound-assisted extraction: obtaining compounds from agro-food waste. YouTube. Available at: [\[Link\]](#)
- Topalović, V., et al. (2023). Microwave-Assisted Extraction of Bioactive Compounds from Mandarin Peel: A Comprehensive Biorefinery Strategy. Foods. Available at: [\[Link\]](#)
- Karami, M., et al. (2021). The organotin contaminants in food: Sources and methods for detection: A systematic review and meta-analysis. Food and Chemical Toxicology. Available at: [\[Link\]](#)
- Mandal, V., et al. (2010). Optimization of microwave assisted extraction of bioactive flavonolignan - silybinin. ACG Publications. Available at: [\[Link\]](#)

Need Custom Synthesis?

BenchChem offers custom synthesis for rare earth carbides and specific isotopic labeling.

Email: info@benchchem.com or [Request Quote Online](#).

Sources

- 1. nmkl.org [nmkl.org]
- 2. www2.gov.bc.ca [www2.gov.bc.ca]
- 3. yadda.icm.edu.pl [yadda.icm.edu.pl]
- 4. pdf.benchchem.com [pdf.benchchem.com]
- 5. Determination of tributyltin by automated in-tube solid-phase microextraction coupled with HPLC-ES-MS - Journal of Analytical Atomic Spectrometry (RSC Publishing) [pubs.rsc.org]
- 6. pjoes.com [pjoes.com]
- 7. researchgate.net [researchgate.net]
- 8. atsdr.cdc.gov [atsdr.cdc.gov]
- 9. researchgate.net [researchgate.net]
- 10. arpat.toscana.it [arpat.toscana.it]
- 11. Development of an Analytical Method for Determining Tributyltin and Triphenyltin in Seawater, Sediment, and Mussel Samples Using GC-FPD and GC-MS – TOF [pjoes.com]

- 12. Liquid–solid extraction of tributyltin from marine samples - Analyst (RSC Publishing) [pubs.rsc.org]
- 13. Liquid–solid extraction of tributyltin from marine samples - Analyst (RSC Publishing) [pubs.rsc.org]
- 14. researchgate.net [researchgate.net]
- 15. Validation of a method for the determination of tributyltin in seawater by stir bar sorptive extraction-liquid chromatography tandem mass spectrometry - PubMed [pubmed.ncbi.nlm.nih.gov]
- 16. A new validated analytical method for the determination of tributyltin in water samples at the quantification level set by the European Union - PubMed [pubmed.ncbi.nlm.nih.gov]
- 17. Frontiers | Spatial and temporal distribution of tributyltin in the coastal environment of the Croatian Adriatic (2016-2023): TBT remains a cause for concern [frontiersin.org]
- 18. Development of an analytical method for organotin compounds in fortified flour samples using microwave-assisted extraction and normal-phase HPLC with UV detection - PubMed [pubmed.ncbi.nlm.nih.gov]
- 19. acgpubs.org [acgpubs.org]
- 20. Determination of tributyltin in marine sediment and waters by pressurised solvent extraction and liquid chromatography-tandem mass spectrometry - PubMed [pubmed.ncbi.nlm.nih.gov]
- 21. researchgate.net [researchgate.net]
- To cite this document: BenchChem. [Cross-validation of different extraction methods for tributyltin]. BenchChem, [2026]. [Online PDF]. Available at: [https://www.benchchem.com/product/b142046/docs#cross-validation-of-different-extraction-methods-for-tributyltin]

Disclaimer & Data Validity:

The information provided in this document is for Research Use Only (RUO) and is strictly not intended for diagnostic or therapeutic procedures. While BenchChem strives to provide accurate protocols, we make no warranties, express or implied, regarding the fitness of this product for every specific experimental setup.

Technical Support: The protocols provided are for reference purposes. Unsure if this reagent suits your experiment?

Need Industrial/Bulk Grade? [Request Custom Synthesis Quote](#)

BenchChem

Our mission is to be the trusted global source of essential and advanced chemicals, empowering scientists and researchers to drive progress in science and industry.

Contact

Address: 3281 E Guasti Rd
Ontario, CA 91761, United States
Phone: (601) 213-4426
Email: info@benchchem.com

[Contact our Ph.D. Support Team for a compatibility check](#)