

Vilsmeier-Haack Reaction of Pyrazoles: A Technical Support Center

Author: BenchChem Technical Support Team. **Date:** May 2026

Compound of Interest

Compound Name: 5-(4-methoxyphenyl)-1-methyl-1H-pyrazole-4-carbaldehyde

CAS No.: 689250-54-2

Cat. No.: B1419862

[Get Quote](#)

Welcome to the Technical Support Center for the Vilsmeier-Haack Reaction of Pyrazoles. This guide is designed for researchers, scientists, and drug development professionals to navigate the complexities of this versatile formylation reaction. As Senior Application Scientists, we provide not just protocols, but the underlying rationale to empower you to troubleshoot and optimize your experiments effectively.

Troubleshooting Guide: From Unexpected Results to Optimized Yields

This section addresses common issues encountered during the Vilsmeier-Haack formylation of pyrazoles in a question-and-answer format, providing in-depth explanations and actionable solutions.

Question 1: My reaction yield is significantly lower than expected. What are the potential causes and how can I improve it?

Answer:

Low yields in the Vilsmeier-Haack reaction of pyrazoles can stem from several factors, ranging from reagent quality to reaction conditions and the electronic nature of your substrate.

Underlying Causes & Solutions:

- **Substrate Reactivity:** The Vilsmeier-Haack reaction is an electrophilic aromatic substitution, and its success is highly dependent on the electron density of the pyrazole ring.[1][2]
 - **Electron-Withdrawing Groups (EWGs):** Pyrazoles bearing strong electron-withdrawing groups (e.g., nitro, cyano) or bulky substituents exhibit low reactivity, sometimes resulting in no product formation.[2] In such cases, consider using harsher reaction conditions (higher temperature, longer reaction time) with caution, as this may also promote byproduct formation.
 - **N-unsubstituted Pyrazoles:** Pyrazoles without a substituent on the nitrogen atom may fail to undergo formylation at the 4-position under standard conditions.[3] Protection of the NH group with a suitable group that can be later removed is a viable strategy.
- **Reagent Quality and Stoichiometry:**
 - **DMF Decomposition:** Old or improperly stored N,N-dimethylformamide (DMF) can decompose to dimethylamine, which can react with the Vilsmeier reagent and reduce its effective concentration.[4] Always use anhydrous, high-purity DMF from a freshly opened bottle. A quick "waft test" for a fishy odor can indicate decomposition.[4]
 - **POCl₃ Hydrolysis:** Phosphorus oxychloride (POCl₃) is sensitive to moisture. Ensure it is handled under anhydrous conditions.
 - **Reagent Ratio:** The molar ratio of POCl₃ to DMF and the substrate is critical. An excess of the Vilsmeier reagent is often necessary for efficient formylation. However, a large excess can sometimes lead to diformylation or other side reactions. Optimization of the POCl₃:DMF:pyrazole ratio is recommended for each specific substrate. For instance, increasing the equivalents of POCl₃ has been shown to improve yields in some cases.
- **Reaction Temperature:**

- Insufficient Temperature: The formylation of less reactive pyrazoles may require heating. Reactions are typically run between room temperature and 80 °C, with some protocols extending to 120 °C.[2][5]
- Excessive Temperature: Higher temperatures can lead to the decomposition of the Vilsmeier reagent and the formation of byproducts.[6] Careful temperature control is crucial.

Experimental Protocol for Yield Optimization:

- Reagent Preparation:
 - Under an inert atmosphere (Argon or Nitrogen), add freshly distilled POCl₃ (1.5 - 4 equivalents) dropwise to anhydrous DMF (used as both reagent and solvent, or in a co-solvent like DCM) at 0 °C with stirring.
 - Allow the mixture to stir at 0 °C for 30-60 minutes to pre-form the Vilsmeier reagent (a whitish solid may form).
- Reaction Execution:
 - Dissolve your pyrazole substrate (1 equivalent) in anhydrous DMF.
 - Add the substrate solution dropwise to the pre-formed Vilsmeier reagent at 0 °C.
 - Slowly warm the reaction to the desired temperature (start with room temperature and incrementally increase in subsequent experiments if no conversion is observed).
 - Monitor the reaction progress by Thin Layer Chromatography (TLC).
- Work-up:
 - Once the reaction is complete, cool the mixture in an ice bath.
 - Carefully quench the reaction by slowly pouring it into a stirred mixture of ice and a saturated aqueous solution of a base (e.g., sodium carbonate, sodium bicarbonate, or sodium hydroxide) until the pH is basic (pH > 10).[7]

- Stir the mixture until the intermediate iminium salt is fully hydrolyzed to the aldehyde.
- Extract the product with a suitable organic solvent (e.g., ethyl acetate, dichloromethane).
- Wash the organic layer with brine, dry over anhydrous sodium sulfate, and concentrate under reduced pressure.
- Purify the crude product by column chromatography.

Question 2: I have isolated an unexpected byproduct. What are the common side reactions and how can I avoid them?

Answer:

Several byproducts can form during the Vilsmeier-Haack reaction of pyrazoles, often due to the reactivity of the reagents or specific functionalities on the substrate.

Common Byproducts and Their Prevention:

Byproduct Type	Formation Mechanism	Prevention Strategies
Diformylated Pyrazole	Occurs with highly activated pyrazole rings or with a large excess of the Vilsmeier reagent. The initially formed pyrazole-4-carboxaldehyde can undergo a second formylation.	- Carefully control the stoichiometry of the Vilsmeier reagent. - Use milder reaction conditions (lower temperature, shorter reaction time).
Chlorinated Byproducts	The Vilsmeier reagent can act as a chlorinating agent, especially at higher temperatures. This is particularly observed with substrates containing hydroxyl groups or other susceptible functionalities. For example, a hydroxyl group on a side chain can be substituted by a chlorine atom. ^[8] A methoxy group in a methoxyethoxy side chain has also been shown to be cleaved and replaced by chlorine. ^[7]	- Use the minimum necessary reaction temperature. - Protect sensitive functional groups prior to the Vilsmeier-Haack reaction.
Hydroxymethylated Pyrazole	Prolonged heating of DMF can lead to its decomposition and the in situ generation of formaldehyde, which can then react with the electron-rich pyrazole. ^[8]	- Avoid unnecessarily long reaction times and high temperatures. - Use fresh, high-purity DMF.
Dehydrochlorinated Products	If the pyrazole substrate contains a suitable leaving group (e.g., a chloroethyl group), elimination can occur under the reaction conditions to form a vinylpyrazole, which	- Modify the substrate to avoid labile leaving groups if possible. - Use milder reaction conditions.

may or may not be
subsequently formylated.[8]

N-Formylated Byproducts	In some cases, formylation can occur on a nitrogen atom of the pyrazole ring, particularly if the C-4 position is blocked or deactivated.	- Ensure the C-4 position is accessible and activated for electrophilic attack. - For N-unsubstituted pyrazoles, consider N-protection.
Dealkylated Pyrazoles	With certain bulky substituents on the pyrazole nitrogen, dealkylation can be observed as a side reaction.[8]	- Avoid excessively harsh conditions (high temperature, long reaction times). - Consider the stability of the N-substituent under acidic conditions.

Visualizing Byproduct Formation:

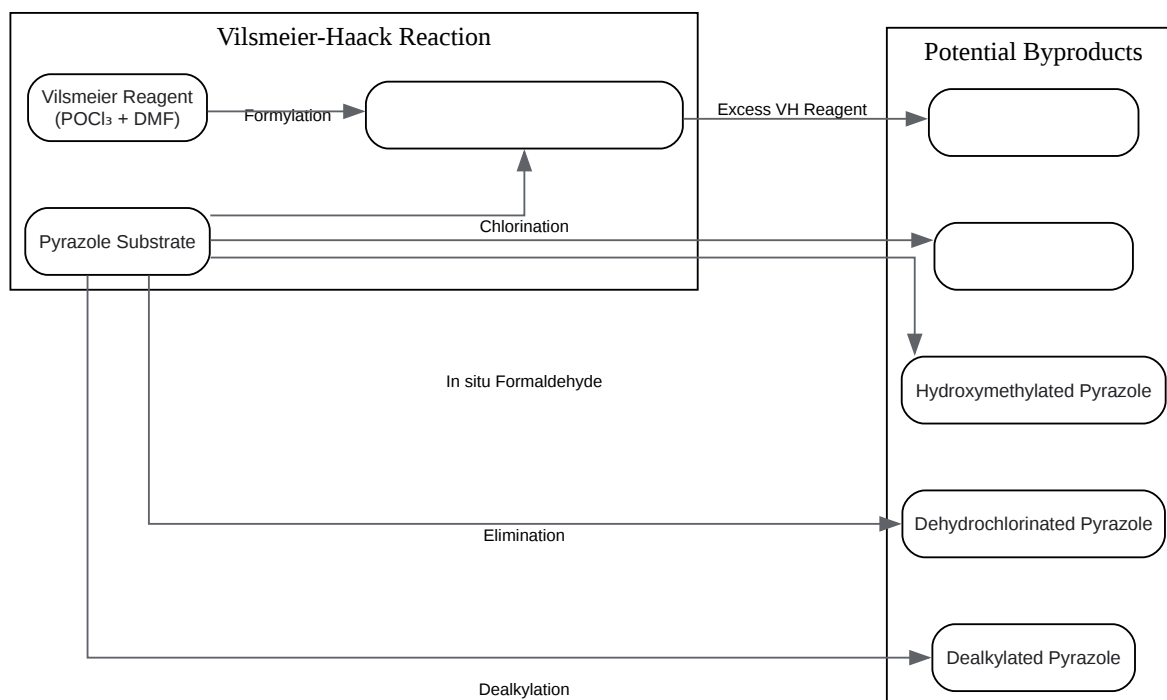

[Click to download full resolution via product page](#)

Caption: Potential reaction pathways in the Vilsmeier-Haack formylation of pyrazoles.

Frequently Asked Questions (FAQs)

Q1: What is the mechanism of the Vilsmeier-Haack reaction on pyrazoles?

A: The Vilsmeier-Haack reaction proceeds in three main stages:

- Formation of the Vilsmeier Reagent: N,N-dimethylformamide (DMF) reacts with phosphorus oxychloride (POCl₃) to form an electrophilic chloromethyliminium salt, commonly known as the Vilsmeier reagent.^{[1][2]}

- **Electrophilic Attack:** The electron-rich C-4 position of the pyrazole ring acts as a nucleophile and attacks the electrophilic carbon of the Vilsmeier reagent. The aromaticity of the pyrazole ring is a driving force for this step.[2]
- **Hydrolysis:** The resulting iminium salt intermediate is then hydrolyzed during aqueous work-up to yield the final pyrazole-4-carboxaldehyde.[2]

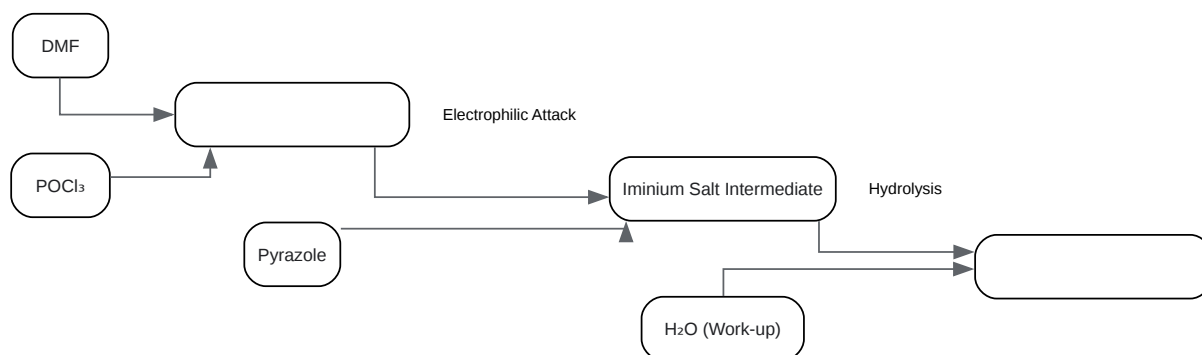

[Click to download full resolution via product page](#)

Caption: Simplified workflow of the Vilsmeier-Haack reaction on pyrazoles.

Q2: Why is the formylation generally regioselective for the C-4 position of the pyrazole ring?

A: The regioselectivity of the Vilsmeier-Haack reaction on pyrazoles is governed by the electronic properties of the pyrazole ring. The two nitrogen atoms in the ring exert a combined electron-withdrawing effect on the adjacent C-3 and C-5 positions, reducing their electron density. This deactivation makes the C-4 position the most electron-rich and, therefore, the most susceptible to electrophilic attack.[2]

Q3: Can I perform a Vilsmeier-Haack reaction on an N-unsubstituted pyrazole?

A: It is generally challenging to achieve C-4 formylation on an N-unsubstituted pyrazole under standard Vilsmeier-Haack conditions.[3] The acidic nature of the N-H proton can lead to side reactions or prevent the desired electrophilic substitution. A common strategy to overcome this is to protect the pyrazole nitrogen with a suitable protecting group (e.g., a benzyl or tosyl group) before the formylation and then deprotect it after the reaction.

Q4: What is the standard work-up procedure for a Vilsmeier-Haack reaction?

A: A typical work-up involves carefully quenching the reaction mixture by pouring it into ice-cold water or a basic solution (like aqueous sodium carbonate or sodium hydroxide) to neutralize the acidic components and hydrolyze the intermediate iminium salt.[7] The product is then extracted with an organic solvent. It is crucial to perform the quenching step slowly and with efficient cooling, as the hydrolysis of excess POCl_3 is highly exothermic.

Standard Quenching and Extraction Protocol:

- Cool the reaction vessel in an ice-water bath.
- Prepare a separate beaker containing crushed ice and a saturated aqueous solution of NaHCO_3 or Na_2CO_3 .
- Slowly and carefully, with vigorous stirring, pour the reaction mixture into the basic ice slurry.
- Continue stirring until the hydrolysis is complete (this can be monitored by the cessation of gas evolution and the disappearance of the intermediate on TLC).
- Transfer the mixture to a separatory funnel and extract the aqueous layer with an appropriate organic solvent (e.g., EtOAc, CH_2Cl_2) multiple times.
- Combine the organic extracts, wash with brine, dry over an anhydrous drying agent (e.g., MgSO_4 or Na_2SO_4), filter, and concentrate in vacuo.
- Purify the crude product using column chromatography on silica gel.[7]

References

- Molecules. (2022). 3-(2-Chloroethoxy)-1-(4-methoxyphenyl)-1H-pyrazole-4-carbaldehyde. MDPI. [\[Link\]](#)
- Journal of Chemical Research. (2005). Vilsmeier—Haack Reaction on Hydrazones: A Convenient Synthesis of 4-Formylpyrazoles.
- ResearchGate. (n.d.). Vilsmeier-Haack formylation of 1H-pyrazoles. [\[Link\]](#)
- Chemistry Steps. (n.d.). Vilsmeier-Haack Reaction. [\[Link\]](#)
- Molecules. (2022). 3-(2-Chloroethoxy)-1-(4-methoxyphenyl)-1H-pyrazole-4-carbaldehyde. MDPI. [\[Link\]](#)
- Asian Journal of Research in Chemistry. (2018). A Comparative study of Vilsmeier-Haack Formylation Reactions With Phenols Under Solvent Less And Solvent Conditions.
- Reddit. (2024). Vilsmeier Haack Reaction : r/OrganicChemistry. [\[Link\]](#)
- RSC Publishing. (2018). Vilsmeier—Haack reagent-promoted formyloxylation of α -chloro-N-arylamides by formamide. [\[Link\]](#)
- Reddit. (2021). Having some troubles with a Vilsmeier-Haack reaction (more infos about my attempts in the comments). [\[Link\]](#)
- Chemistry Stack Exchange. (2021). About the Vilsmeier-Haack formylation of this compound. [\[Link\]](#)
- National Institutes of Health. (2023). Unravelling the synthetic and therapeutic aspects of five, six and fused heterocycles using Vilsmeier—Haack reagent. [\[Link\]](#)
- Arkivoc. (2019). Synthesis of poly-functionalized pyrazoles under Vilsmeier-Haack reaction conditions. [\[Link\]](#)
- Degres Journal. (2022). Ultrasonic and Microwave Accelerated Vilsmeier-Haack Formylation: An Energy-efficient Route to Synthesize Pyrazole-4-Carbaldehydes.
- NROChemistry. (n.d.). Vilsmeier-Haack Reaction. [\[Link\]](#)

- Semantic Scholar. (2018). Synthesis of poly-functionalized pyrazoles under Vilsmeier-Haack reaction conditions. [[Link](#)]

Need Custom Synthesis?

BenchChem offers custom synthesis for rare earth carbides and specific isotopic labeling.

Email: info@benchchem.com or [Request Quote Online](#).

Sources

- 1. Vilsmeier-Haack Reaction - Chemistry Steps [[chemistrysteps.com](https://www.chemistrysteps.com)]
- 2. Unravelling the synthetic and therapeutic aspects of five, six and fused heterocycles using Vilsmeier–Haack reagent - PMC [[pmc.ncbi.nlm.nih.gov](https://pubmed.ncbi.nlm.nih.gov)]
- 3. [researchgate.net](https://www.researchgate.net) [[researchgate.net](https://www.researchgate.net)]
- 4. [reddit.com](https://www.reddit.com) [[reddit.com](https://www.reddit.com)]
- 5. [ijpcbs.com](https://www.ijpcbs.com) [[ijpcbs.com](https://www.ijpcbs.com)]
- 6. [growingscience.com](https://www.growingscience.com) [[growingscience.com](https://www.growingscience.com)]
- 7. [mdpi.com](https://www.mdpi.com) [[mdpi.com](https://www.mdpi.com)]
- 8. Organic Syntheses Procedure [[orgsyn.org](https://www.orgsyn.org)]
- To cite this document: BenchChem. [Vilsmeier-Haack Reaction of Pyrazoles: A Technical Support Center]. BenchChem, [2026]. [Online PDF]. Available at: [<https://www.benchchem.com/product/b1419862/docs#vilsmeier-haack-reaction-of-pyrazoles-a-technical-support-center>]

Disclaimer & Data Validity:

The information provided in this document is for Research Use Only (RUO) and is strictly not intended for diagnostic or therapeutic procedures. While BenchChem strives to provide accurate protocols, we make no warranties, express or implied, regarding the fitness of this product for every specific experimental setup.

Technical Support: The protocols provided are for reference purposes. Unsure if this reagent suits your experiment?

Need Industrial/Bulk Grade? [Request Custom Synthesis Quote](#)

BenchChem

Our mission is to be the trusted global source of essential and advanced chemicals, empowering scientists and researchers to drive progress in science and industry.

Contact

Address: 3281 E Guasti Rd
Ontario, CA 91761, United States
Phone: (601) 213-4426
Email: info@benchchem.com

[Contact our Ph.D. Support Team for a compatibility check](#)