

# Reproducibility of Nas-181's Effects on 5-HT Release: A Comparative Guide

**Author:** BenchChem Technical Support Team. **Date:** April 2026

## Compound of Interest

Compound Name: Nas-181  
CAS No.: 205242-62-2  
Cat. No.: B1419717

[Get Quote](#)

For Researchers, Scientists, and Drug Development Professionals

This guide provides a comprehensive comparison of the effects of the selective 5-HT<sub>1B</sub> receptor antagonist, **Nas-181**, on serotonin (5-HT) release. It examines the reproducibility of its effects and contrasts its performance with other relevant compounds. Detailed experimental protocols and signaling pathway diagrams are included to facilitate a deeper understanding of the underlying mechanisms and to aid in the design of future research.

## Comparison of Nas-181 and Alternative Compounds on 5-HT Release

The following table summarizes the quantitative effects of **Nas-181** and alternative compounds on 5-HT release, primarily in the rat frontal cortex, as measured by in vivo microdialysis. The data highlights the modulatory effects of these compounds, both alone and in combination with other agents that alter serotonergic transmission.

| Compound  | Class                       | Dose/Concentration  | Brain Region                                     | Experimental Condition                                 | Effect on Extracellular 5-HT                 | Reference |
|-----------|-----------------------------|---|--|--|--|-----------|
| Nas-181   | Selective 5-HT1B Antagonist | 1 $\mu$ M   | Rat Frontal Cortex                               | Co-perfusion with 5-HT1B agonist CP93129 (0.1 $\mu$ M) | Attenuated the suppressant effect of CP93129 | [1][2]    |
| 1 $\mu$ M | Rat Frontal Cortex          | Co-perfusion with CP93129 (0.1 $\mu$ M) and fluvoxamine (3 $\mu$ M) | Attenuated the suppressant effect of CP93129     | [1][2]   |  |           |
| 1 $\mu$ M | Rat Frontal Cortex          | Alone   | Reduced 5-HT levels (suggesting partial agonism) | [1]  |  |           |
| GR127935  | Mixed 5-HT1B/1D Antagonist  | 10 $\mu$ M  | Rat Frontal Cortex                               | Co-perfusion with 5-HT1B agonist CP93129 (0.1 $\mu$ M) | Attenuated the suppressant effect of CP93129 |           |

|                     |                             |   |   |  |   |
|---------------------|-----------------------------|---|---|--|---|
| 10 $\mu$ M          | Rat Frontal Cortex          | Co-perfusion with CP93129 (0.1 $\mu$ M) and fluvoxamine (3 $\mu$ M) | Attenuated the suppressant effect of CP93129        |  |   |
| 10 $\mu$ M          | Rat Frontal Cortex          | Alone   | Reduced 5-HT levels (suggesting partial agonism)    |  |   |
| 1 and 5 mg/kg, i.v. | Rat Frontal Cortex          | In combination with WAY100635 and paroxetine                        | Up to 5-fold increase                               |  |   |
| SB224289            | Selective 5-HT1B Antagonist | 1 $\mu$ M   | Rat Frontal Cortex                                  | Co-perfusion with 5-HT1B agonist CP93129 (0.1 $\mu$ M) | Did not attenuate the suppressant effect of CP93129 |
| 1 $\mu$ M           | Rat Frontal Cortex          | Co-perfusion with CP93129 (0.1 $\mu$ M) and fluvoxamine (3 $\mu$ M) | Did not attenuate the suppressant effect of CP93129 |  |   |

|             |   |                                       |  |   |   |
|-------------|---|---------------------------------------|--|---|---|
| 1 $\mu$ M   | Rat Frontal Cortex                            | Alone                                 | Reduced 5-HT levels (suggesting partial agonism) |   |   |
| Fluvoxamine | Selective Serotonin Reuptake Inhibitor (SSRI) | 3 $\mu$ M                             | Rat Frontal Cortex                               | Co-perfusion with CP93129 (0.1 $\mu$ M) | Reduced the suppressant effect of CP93129 |
| 1 $\mu$ M   | Mouse Prefrontal Cortex                       | Co-perfusion with Nas-181 (1 $\mu$ M) | Synergistic increase in 5-HT levels              |   |   |

## Experimental Protocols

### In Vivo Microdialysis in the Rat Frontal Cortex

This protocol outlines the key steps for measuring extracellular 5-HT levels in the frontal cortex of anesthetized rats.

#### 1. Animal Preparation and Surgery:

- Male Wistar rats (250-300 g) are anesthetized with an appropriate anesthetic (e.g., chloral hydrate, 400 mg/kg, i.p.).
- The animal is placed in a stereotaxic frame.
- A guide cannula is implanted, targeting the frontal cortex using stereotaxic coordinates (e.g., AP +3.2 mm, L -0.8 mm from bregma; DV -1.0 mm from the skull surface).
- The cannula is secured with dental cement and anchor screws.
- A dummy cannula is inserted to maintain patency, and the animal is allowed to recover for at least 24 hours.

## 2. Microdialysis Procedure:

- On the day of the experiment, the dummy cannula is replaced with a microdialysis probe (e.g., concentric probe with a 4 mm membrane).
- The probe is perfused with artificial cerebrospinal fluid (aCSF; e.g., 147 mM NaCl, 4 mM KCl, 2.3 mM CaCl<sub>2</sub>) at a constant flow rate (e.g., 1.5 µl/min) using a microinfusion pump.
- A stabilization period of at least 60 minutes is allowed to achieve a stable baseline of extracellular 5-HT.
- Dialysate samples are collected at regular intervals (e.g., every 15 or 20 minutes) into vials containing an antioxidant solution (e.g., 0.02 M acetic acid) to prevent 5-HT degradation.
- At least four consecutive baseline samples with less than 10% variation in 5-HT concentration are collected before drug administration.

## 3. Drug Administration:

- Drugs (e.g., **Nas-181**, GR127935, SB224289, fluvoxamine, or the agonist CP93129) are dissolved in the aCSF and administered locally into the frontal cortex via reverse dialysis through the microdialysis probe.
- For systemic administration, drugs can be injected intraperitoneally (i.p.) or intravenously (i.v.).

## 4. Sample Analysis:

- The concentration of 5-HT in the dialysate samples is quantified using High-Performance Liquid Chromatography with Electrochemical Detection (HPLC-ECD).
- 5-HT is separated on a reverse-phase C18 column.
- The electrochemical detector is set at an oxidizing potential optimal for 5-HT (e.g., +0.65 V).
- Data is typically expressed as a percentage of the mean baseline 5-HT concentration.

## 5. Histological Verification:

- At the end of the experiment, the animal is euthanized, and the brain is removed.
- The brain is sectioned and stained to histologically verify the correct placement of the microdialysis probe.

## Signaling Pathways and Experimental Workflows

### 5-HT1B Receptor Signaling Pathway

The 5-HT1B receptor is a G-protein coupled receptor (GPCR) that primarily couples to the inhibitory G-protein, *Gai/o*. Its activation leads to the inhibition of adenylyl cyclase, resulting in decreased intracellular cyclic AMP (cAMP) levels and subsequently reduced protein kinase A (PKA) activity. This canonical pathway contributes to the receptor's primary function as an autoreceptor, inhibiting the release of serotonin from the presynaptic terminal.

Beyond this classical pathway, the 5-HT1B receptor can also activate the mitogen-activated protein kinase/extracellular signal-regulated kinase (MAPK/ERK) pathway. This activation is more complex, involving both the *Gai/o* subunit and  $\beta$ -arrestin proteins. Furthermore, activation of the 5-HT1B receptor can modulate ion channel activity, leading to an increase in  $K^+$  conductance and a decrease in  $Ca^{2+}$  conductance, both of which contribute to the hyperpolarization of the presynaptic membrane and the inhibition of neurotransmitter release.

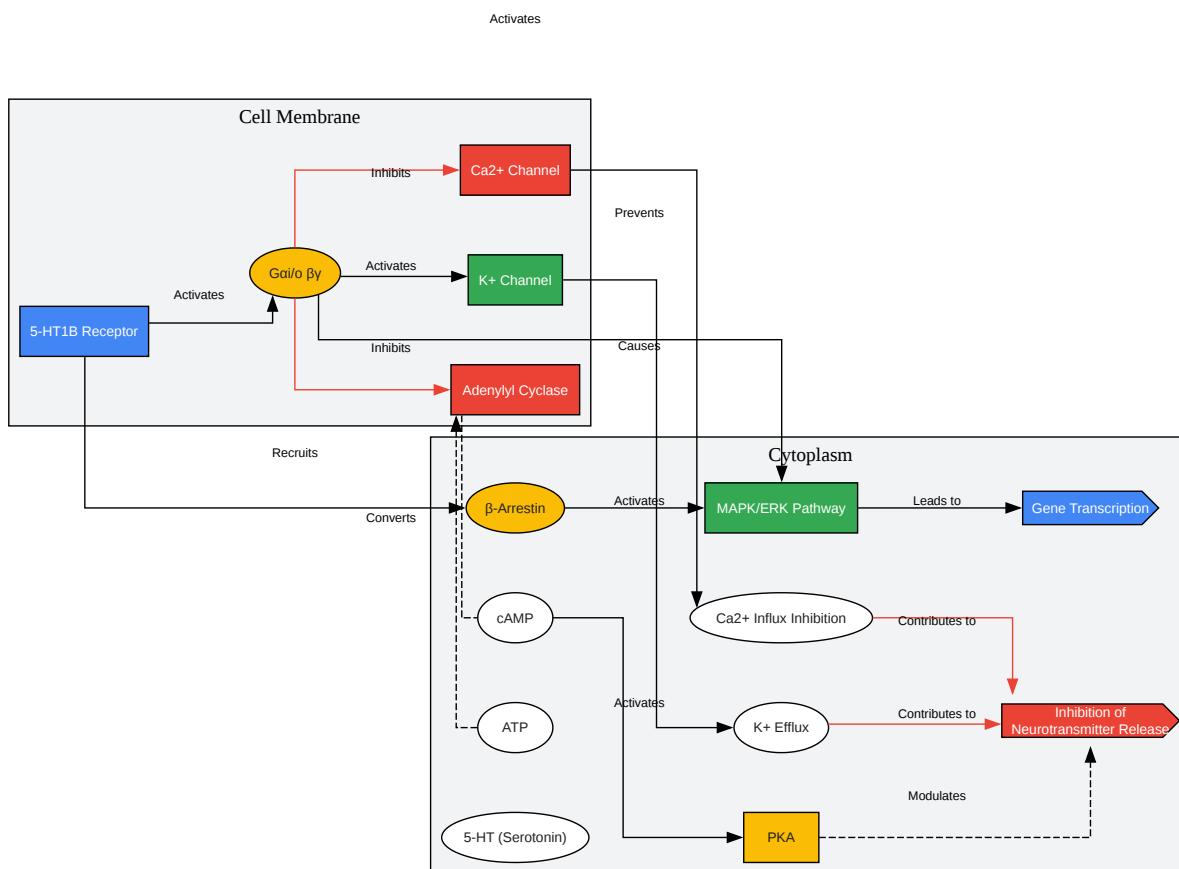

[Click to download full resolution via product page](#)

Caption: 5-HT1B receptor signaling cascades.

## Experimental Workflow for Comparing 5-HT1B Antagonists

The following diagram illustrates a typical experimental workflow for comparing the effects of different 5-HT1B antagonists on 5-HT release using in vivo microdialysis.

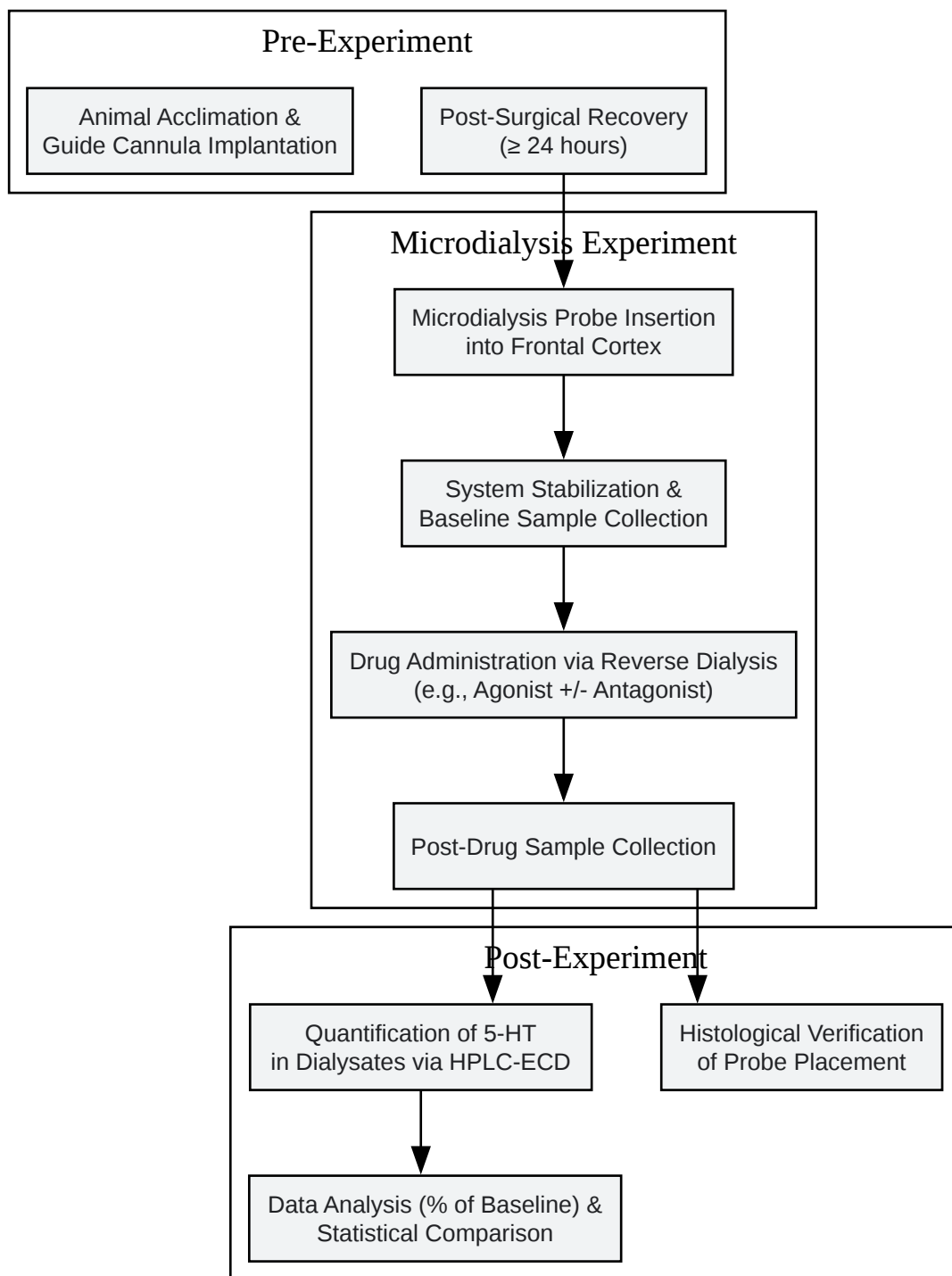

[Click to download full resolution via product page](#)

Caption: Workflow for in vivo microdialysis experiments.

## Reproducibility and Concluding Remarks

The available evidence suggests that the effect of **Nas-181** on 5-HT release is reproducible under specific conditions. Multiple studies have demonstrated that the ability of **Nas-181** and other 5-HT<sub>1B</sub> antagonists to increase extracellular 5-HT is significantly enhanced when co-administered with a serotonin reuptake inhibitor, such as fluvoxamine. This indicates that the tonic activation of 5-HT<sub>1B</sub> autoreceptors is relatively low under basal conditions and that an elevation of synaptic 5-HT is necessary to unmask the full effect of their blockade.

When administered alone, **Nas-181**, along with GR127935 and SB224289, has been observed to slightly reduce basal 5-HT levels, a finding that suggests these compounds may possess partial agonist properties at the 5-HT<sub>1B</sub> receptor.

In direct comparison for their ability to counteract the 5-HT-lowering effect of the 5-HT<sub>1B</sub> agonist CP93129, **Nas-181** and GR127935 were effective, whereas SB224289 was not under the tested conditions. This highlights potential differences in the pharmacological profiles of these antagonists.

In conclusion, **Nas-181** is a potent 5-HT<sub>1B</sub> receptor antagonist whose effect on 5-HT release is critically dependent on the surrounding serotonergic tone. For researchers and drug development professionals, this underscores the importance of considering the experimental conditions, particularly the concurrent use of SSRIs, when evaluating the efficacy of 5-HT<sub>1B</sub> antagonists as modulators of serotonergic neurotransmission. The detailed protocols and pathway diagrams provided in this guide offer a framework for designing and interpreting such studies.

### *Need Custom Synthesis?*

*BenchChem offers custom synthesis for rare earth carbides and specific isotopic labeling.*

*Email: [info@benchchem.com](mailto:info@benchchem.com) or [Request Quote Online](#).*

## References

- [1. researchgate.net \[researchgate.net\]](#)
- [2. An evaluation of the effect of NAS-181, a new selective 5-HT\(1B\) receptor antagonist, on extracellular 5-HT levels in rat frontal cortex - PubMed \[pubmed.ncbi.nlm.nih.gov\]](#)
- To cite this document: BenchChem. [Reproducibility of Nas-181's Effects on 5-HT Release: A Comparative Guide]. BenchChem, [2026]. [Online PDF]. Available at: [\[https://www.benchchem.com/product/b1419717/docs#reproducibility-of-nas-181-s-effects-on-5-ht-release-a-comparative-guide\]](https://www.benchchem.com/product/b1419717/docs#reproducibility-of-nas-181-s-effects-on-5-ht-release-a-comparative-guide)

---

### Disclaimer & Data Validity:

The information provided in this document is for Research Use Only (RUO) and is strictly not intended for diagnostic or therapeutic procedures. While BenchChem strives to provide accurate protocols, we make no warranties, express or implied, regarding the fitness of this product for every specific experimental setup.

**Technical Support:** The protocols provided are for reference purposes. Unsure if this reagent suits your experiment?

**Need Industrial/Bulk Grade?** [Request Custom Synthesis Quote](#)

## BenchChem

Our mission is to be the trusted global source of essential and advanced chemicals, empowering scientists and researchers to drive progress in science and industry.

### Contact

Address: 3281 E Guasti Rd

Ontario, CA 91761, United States

Phone: (601) 213-4426

Email: [info@benchchem.com](mailto:info@benchchem.com)

Contact our Ph.D. Support Team for a compatibility check