

A Comprehensive Technical Guide to the Biological Activities of Dimethoxyquinoline Compounds

Author: BenchChem Technical Support Team. **Date:** May 2026

Compound of Interest

Compound Name:	5,7-Dimethoxyquinoline-3-carbaldehyde
CAS No.:	363135-56-2
Cat. No.:	B1419421

[Get Quote](#)

Abstract

The quinoline scaffold represents a privileged structure in medicinal chemistry, forming the core of numerous therapeutic agents with a wide spectrum of pharmacological activities. The introduction of dimethoxy substituents, particularly at the 6- and 7-positions, has been shown to significantly enhance biological efficacy and modulate target specificity. This technical guide provides an in-depth analysis of the diverse biological activities of dimethoxyquinoline compounds, with a primary focus on their well-established anticancer properties. We will explore their multi-mechanistic approaches to cancer therapy, including the inhibition of critical oncogenic kinases, disruption of DNA replication, and modulation of the cytoskeleton. Furthermore, this guide will cover the emerging antimicrobial, anti-inflammatory, and neuroprotective potential of this versatile chemical class. Detailed experimental protocols, comparative quantitative data, and visual diagrams of key pathways are provided to serve as a valuable resource for researchers, scientists, and drug development professionals.

Introduction: The Dimethoxyquinoline Scaffold - A Privileged Structure in Drug Discovery

The quinoline ring system is a ubiquitous heterocyclic motif that plays a prominent role in drug discovery, with derivatives investigated for antimalarial, antibacterial, and anticancer activities. [1][2] Its rigid, planar structure and ability to participate in π - π stacking, hydrogen bonding, and hydrophobic interactions make it an ideal framework for designing molecules that can effectively bind to biological targets. Among the various substituted quinolines, the 6,7-dimethoxyquinazoline and quinoline cores have emerged as critical pharmacophores, particularly in the design of kinase inhibitors and other targeted therapies. [3][4]

The dimethoxy groups are not merely passive substituents; they are crucial for activity. They often act as key hydrogen bond acceptors, anchoring the molecule within the active site of a target enzyme, as seen in interactions with the hinge region of many protein kinases. This substitution pattern enhances the molecule's drug-like properties and provides a vector for further structural modification to optimize potency, selectivity, and pharmacokinetic profiles. [4] [5] This guide will systematically explore the major therapeutic avenues where dimethoxyquinoline derivatives have shown significant promise.

Anticancer Activities: A Multi-Mechanistic Approach

The most extensively documented biological activity of dimethoxyquinoline compounds is their potent and varied anticancer efficacy. [6] These compounds do not rely on a single mode of action but rather engage multiple, critical cellular pathways that are commonly deregulated in cancer. This multi-targeted approach is a significant advantage in oncology, offering the potential to overcome the drug resistance that often develops with single-target agents. [6]

Inhibition of Key Kinases in Oncogenic Signaling

Protein kinases are crucial regulators of cellular signaling pathways, and their dysregulation is a hallmark of many cancers. [3] Dimethoxyquinoline derivatives have been successfully developed as potent inhibitors of several receptor tyrosine kinases (RTKs) that are pivotal drivers of tumor growth, proliferation, and survival. [3]

2.1.1 c-Met Kinase Inhibition

The HGF/c-Met signaling pathway is a critical driver of tumorigenesis and metastasis.[5][7] Abnormal activation of the c-Met receptor tyrosine kinase leads to increased cell proliferation, survival, migration, and invasion.[7] A series of 6,7-dimethoxy-4-anilinoquinolines have been identified as potent inhibitors of c-Met.[7][8] These compounds typically function by competing with ATP for its binding site in the kinase domain, thereby preventing receptor autophosphorylation and the activation of downstream signaling cascades like the RAS-RAF-MEK-ERK and PI3K-AKT-mTOR pathways.[7]

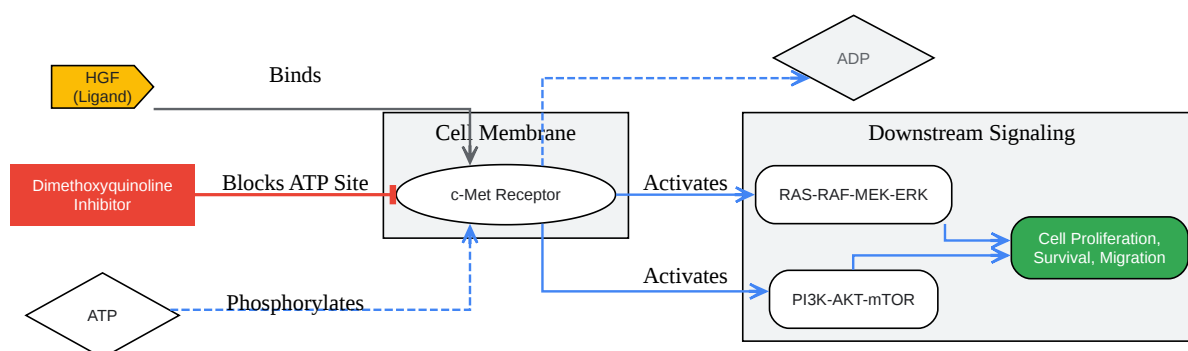

[Click to download full resolution via product page](#)

Caption: Inhibition of the HGF/c-Met signaling pathway by dimethoxyquinoline compounds.

2.1.2 Epidermal Growth Factor Receptor (EGFR) Inhibition

Similar to c-Met, the EGFR is an RTK that is often overexpressed or mutated in various cancers, leading to uncontrolled cell growth.[3] The 4-anilino-6,7-dimethoxyquinazoline scaffold is a cornerstone of many clinically successful EGFR inhibitors.[3] By blocking the ATP-binding site of the EGFR kinase domain, these compounds prevent its autophosphorylation and subsequent activation of downstream pro-survival pathways, ultimately leading to the inhibition of cell proliferation and the induction of apoptosis.[3] One potent example, 4-(3-bromoanilino)-6,7-dimethoxyquinazoline, exhibits an IC_{50} of just 25 pM against the enzyme.[9]

2.1.3 FMS-like Tyrosine Kinase 3 (FLT3) Inhibition

FLT3 is another RTK that has been identified as a critical therapeutic target in acute myeloid leukemia (AML).[2] Specific derivatives of 4-((6,7-dimethoxyquinolin-4-yl)oxy)aniline have been synthesized and shown to be potent FLT3 inhibitors, demonstrating significant antiproliferative activity against AML cell lines.[2]

Compound Class	Target Kinase	Cancer Cell Line	IC ₅₀ (μM)	Reference
6,7-dimethoxy-4-anilinoquinoline (12n)	c-Met	A549 (Lung)	7.3 ± 1.0	[7]
6,7-dimethoxy-4-anilinoquinoline (12n)	c-Met	MCF-7 (Breast)	6.1 ± 0.6	[7]
4-anilinoquinazolin e (DW-8)	Not specified	HCT116 (Colon)	8.50 ± 2.53	[6]
4-anilinoquinazolin e (DW-8)	Not specified	HT29 (Colon)	5.80 ± 0.92	[6]
4-((6,7-dimethoxyquinolin-4-yl)oxy)aniline (12c)	FLT3 (enzyme)	-	0.312	[2]
4-((6,7-dimethoxyquinolin-4-yl)oxy)aniline (12g)	FLT3 (enzyme)	-	0.384	[2]

Table 1: In Vitro cytotoxic and inhibitory activity of representative dimethoxyquinoline kinase inhibitors.

Disruption of DNA Replication and Repair

2.2.1 Topoisomerase I (TOP1) Inhibition

Topoisomerase I is an essential nuclear enzyme that relieves torsional stress in DNA during replication and transcription by creating transient single-strand breaks.[1][5] Certain 4-alkoxy-2-aryl-6,7-dimethoxyquinolines have been discovered to be a new class of potent TOP1 inhibitors.[1] Their mechanism of action is analogous to established anticancer drugs like camptothecin. They stabilize the TOP1-DNA cleavage complex, which prevents the re-ligation of the DNA strand.[1][5] This stabilization transforms the transient enzyme-DNA link into a permanent source of DNA damage, leading to replication fork collapse and the induction of apoptosis in cancer cells.[1] One potent compound, designated 14m, displayed sub-micromolar growth inhibitory (GI₅₀) values against a wide panel of 28 different tumor cell lines.[1]

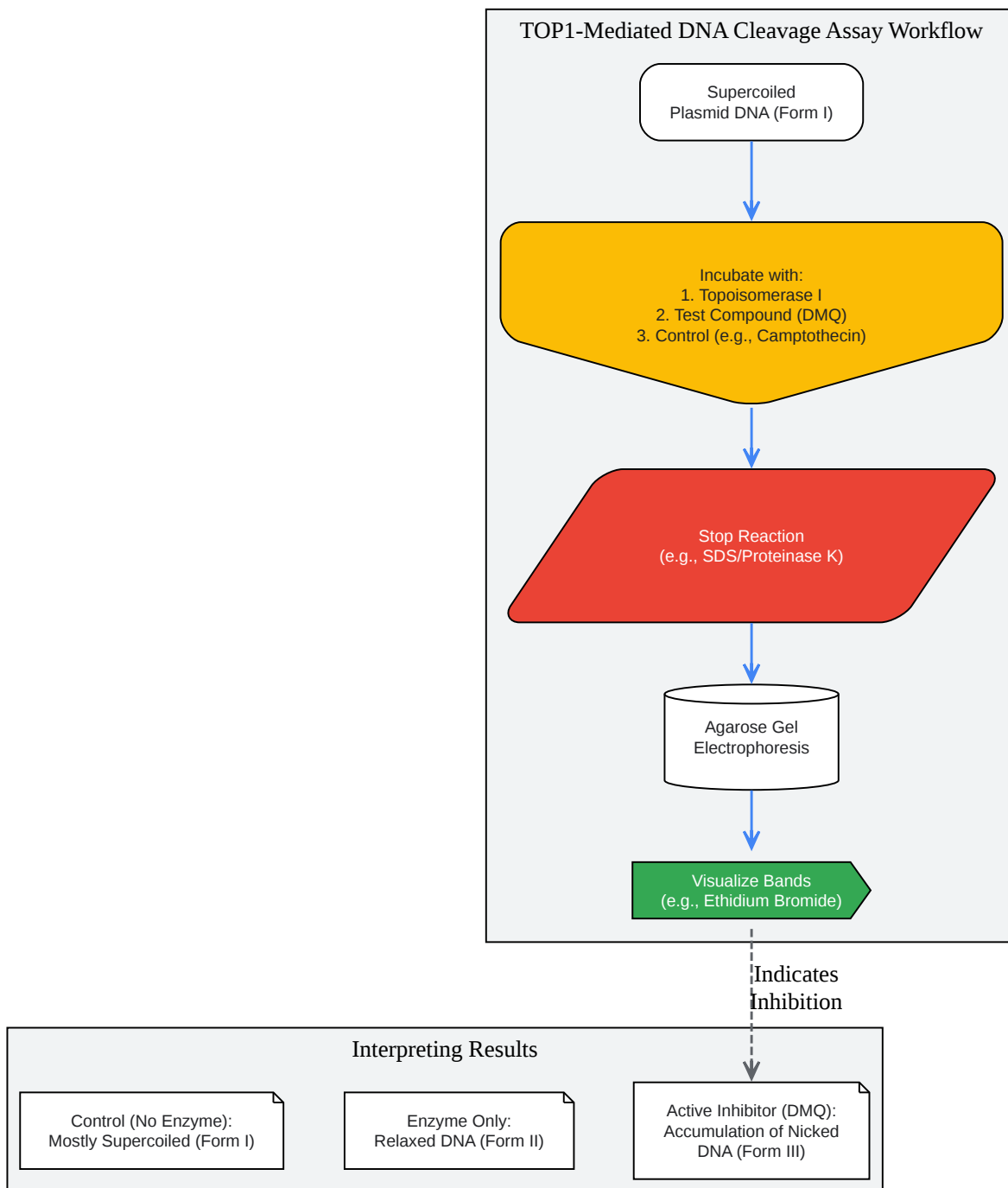

[Click to download full resolution via product page](#)

Caption: Experimental workflow for a Topoisomerase I-mediated DNA cleavage assay.

Targeting the Cytoskeleton: Tubulin Polymerization Inhibition

Microtubules are fundamental components of the cytoskeleton, essential for cell division, motility, and intracellular transport.[10] Agents that disrupt microtubule dynamics are among the most successful classes of anticancer drugs. Some quinoline derivatives have been shown to act as tubulin polymerization inhibitors, arresting cancer cells in the G2/M phase of the cell cycle, which ultimately triggers apoptosis.[1][10]

Epigenetic Modulation: G9a Inhibition

G9a is a histone lysine methyltransferase that plays a key role in epigenetic regulation. Its inhibition is an emerging strategy in cancer therapy. BIX-01294, a known G9a inhibitor, is based on a 6,7-dimethoxyquinazoline core.[11] This has spurred the development of novel 2,4-diamino-6,7-dimethoxyquinoline derivatives as substrate-competitive inhibitors of G9a, highlighting the versatility of the scaffold in targeting non-kinase enzymes.[11]

Reversing Multidrug Resistance (MDR)

A major challenge in chemotherapy is the development of multidrug resistance, often mediated by the overexpression of efflux pumps like P-glycoprotein (P-gp).[12] P-gp actively transports a wide range of anticancer drugs out of the cell, reducing their intracellular concentration and effectiveness.[12] Several 6,7-dimethoxy-1,2,3,4-tetrahydroisoquinoline and 6-methoxy-2-arylquinoline derivatives have been identified as potent P-gp inhibitors.[12][13] These compounds can reverse MDR, restoring the sensitivity of resistant cancer cells to conventional chemotherapeutic agents.[12]

Experimental Protocol: In Vitro Cytotoxicity Assessment (MTT Assay)

This protocol describes a standard colorimetric assay to measure the reduction in cell viability or cytotoxic effects of a compound on cancer cell lines.[6][7]

Objective: To determine the half-maximal inhibitory concentration (IC₅₀) of a dimethoxyquinoline compound.

Materials:

- Human cancer cell lines (e.g., A549, MCF-7, HCT116)
- Complete culture medium (e.g., DMEM or RPMI-1640 with 10% FBS)
- Dimethoxyquinoline test compound, dissolved in DMSO
- Phosphate-Buffered Saline (PBS)
- MTT solution (3-(4,5-dimethylthiazol-2-yl)-2,5-diphenyltetrazolium bromide) at 5 mg/mL in PBS
- Solubilization solution (e.g., DMSO or acidified isopropanol)
- 96-well microplates
- Multichannel pipette
- Microplate reader (570 nm)

Procedure:

- Cell Seeding: Trypsinize and count cells. Seed cells into a 96-well plate at a density of 5,000-10,000 cells/well in 100 μ L of complete culture medium.
- Incubation: Incubate the plate for 24 hours at 37°C in a humidified 5% CO₂ atmosphere to allow for cell attachment.
- Compound Treatment: Prepare serial dilutions of the dimethoxyquinoline compound in culture medium from a concentrated DMSO stock. The final DMSO concentration in the wells should be kept below 0.5% to avoid solvent toxicity. Remove the old medium from the wells and add 100 μ L of the diluted compound solutions. Include vehicle control (medium with DMSO) and blank (medium only) wells.
- Incubation: Incubate the treated plates for 48-72 hours at 37°C in a 5% CO₂ atmosphere.
- MTT Addition: Add 20 μ L of the 5 mg/mL MTT solution to each well and incubate for another 3-4 hours. During this time, viable cells with active mitochondrial dehydrogenases will convert the yellow MTT into purple formazan crystals.

- **Solubilization:** Carefully remove the medium from each well. Add 150 μL of the solubilization solution (e.g., DMSO) to each well to dissolve the formazan crystals. Gently pipette to ensure complete dissolution.
- **Data Acquisition:** Measure the absorbance of each well at 570 nm using a microplate reader.
- **Analysis:** Calculate the percentage of cell viability for each concentration relative to the vehicle control. Plot the viability percentage against the logarithm of the compound concentration and use a non-linear regression analysis to determine the IC_{50} value.

Antimicrobial Properties

While the focus has been on anticancer applications, the quinoline scaffold has a long history in antimicrobial drug discovery. Certain dimethoxyquinazoline and dimethoxyquinoline derivatives have demonstrated interesting activity against a range of pathogens.

Mechanism of Action: Targeting Bacterial Enzymes

Similar to their action in cancer, some dimethoxyquinoline compounds target essential bacterial enzymes. Novel 6,7-dimethoxy-4-piperazinylquinoline derivatives have been investigated as promising antibacterial agents against *Staphylococcus aureus*.^[14] Docking studies suggest these compounds interact with and inhibit DNA gyrase and topoisomerase IV, two crucial enzymes required for bacterial DNA replication, making them attractive targets for antibiotic development.^[14]

Spectrum of Activity

Studies have reported that some dimethoxyquinazoline derivatives possess a broad spectrum of antimicrobial activity, showing inhibitory effects against various Gram-positive bacteria (e.g., *Staphylococcus aureus*, *Bacillus cereus*), Gram-negative bacteria (*Escherichia coli*), and fungi (*Candida albicans*, *Aspergillus fumigatus*).^[15]^[16]

Experimental Protocol: Minimum Inhibitory Concentration (MIC) Assay

This protocol outlines the broth microdilution method to determine the lowest concentration of a compound that visibly inhibits microbial growth.^[15]

Objective: To determine the MIC of a dimethoxyquinoline compound against a specific bacterial or fungal strain.

Materials:

- Bacterial or fungal strain (e.g., *S. aureus* ATCC 29213)
- Appropriate broth medium (e.g., Mueller-Hinton Broth for bacteria, RPMI-1640 for fungi)
- Dimethoxyquinoline test compound, dissolved in DMSO
- Sterile 96-well microplates
- Bacterial inoculum standardized to $\sim 5 \times 10^5$ CFU/mL
- Positive control antibiotic (e.g., Ciprofloxacin)
- Incubator

Procedure:

- **Compound Dilution:** In a 96-well plate, add 50 μ L of broth to all wells except the first column. Add 100 μ L of the test compound at twice the highest desired concentration to the first column.
- **Serial Dilution:** Perform a 2-fold serial dilution by transferring 50 μ L from the first column to the second, mixing, and continuing this process across the plate. Discard the final 50 μ L from the last column. This creates a gradient of compound concentrations.
- **Inoculation:** Add 50 μ L of the standardized microbial inoculum to each well, bringing the total volume to 100 μ L.
- **Controls:** Include a positive control (wells with inoculum and a known antibiotic), a negative/growth control (wells with inoculum and no compound), and a sterility control (wells with broth only).
- **Incubation:** Cover the plate and incubate at 35-37°C for 18-24 hours for bacteria, or as appropriate for fungi.

- Reading Results: The MIC is determined as the lowest concentration of the compound at which there is no visible turbidity (growth). This can be assessed visually or by using a plate reader.

Anti-inflammatory Potential

Inflammation is a complex biological response implicated in numerous diseases. The quinazoline scaffold is known to be associated with anti-inflammatory properties.[3][15]

Inhibition of Inflammatory Mediators

The anti-inflammatory action of some related compounds is mediated through the inhibition of key enzymes in the arachidonic acid cascade. For instance, a phenanthraquinone derivative with a dimethoxy substitution pattern was shown to be a potent dual inhibitor of cyclooxygenase-2 (COX-2) and 5-lipoxygenase (5-LOX).[17] Inhibition of these enzymes reduces the production of pro-inflammatory prostaglandins and leukotrienes, respectively.[17] Similarly, studies on dimethoxy flavones have shown significant inhibition of COX enzymes.[18] More directly, a series of 2-chloro-4-(aryl amino)-6, 7-dimethoxy quinazoline derivatives were synthesized and showed good anti-inflammatory activity in a protein denaturation assay, with one compound having an IC₅₀ value of 1.772 µg/ml.[19]

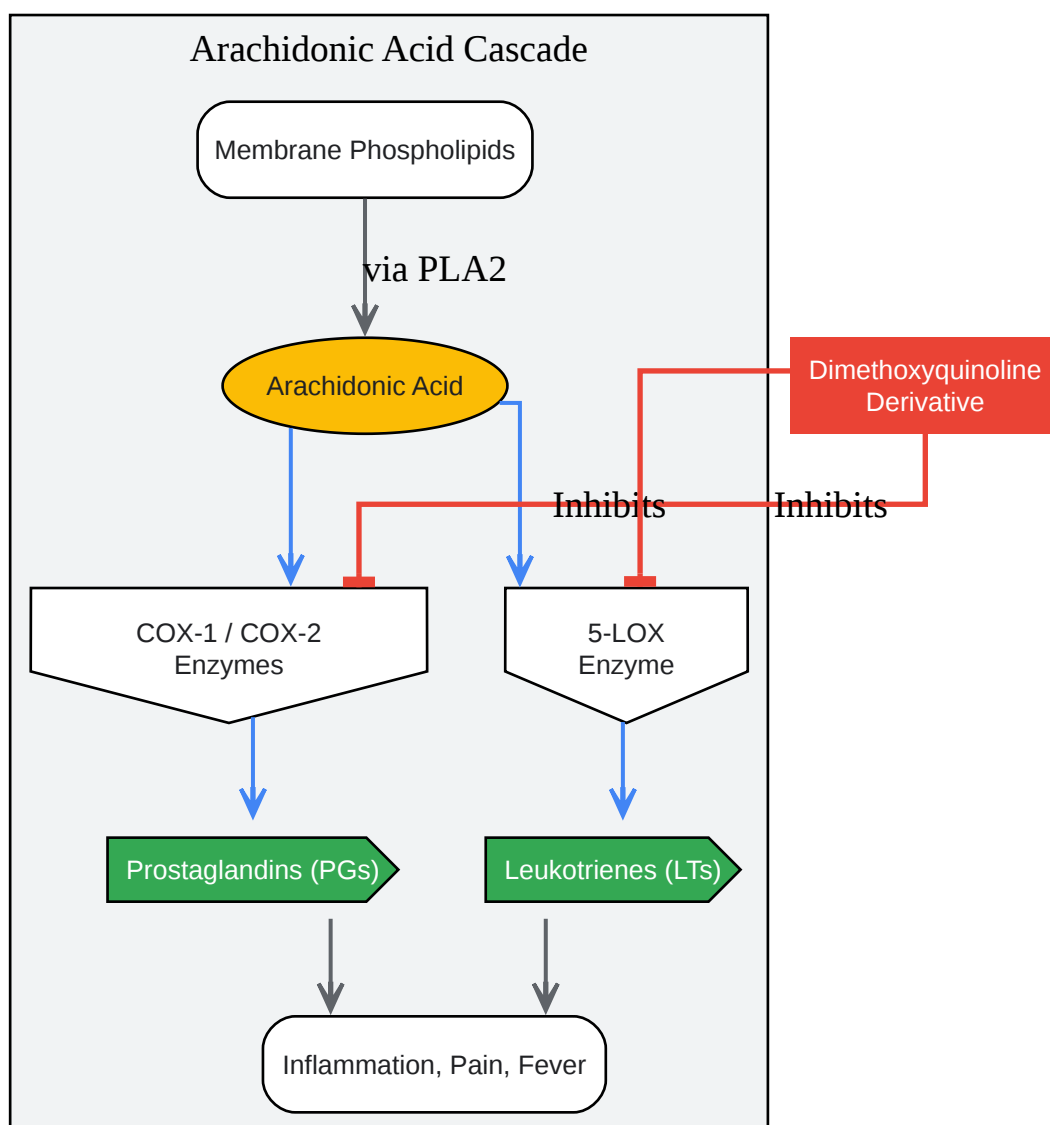

[Click to download full resolution via product page](#)

Caption: Point of intervention for anti-inflammatory dimethoxy-substituted compounds.

Modulation of Pro-inflammatory Cytokines

In addition to enzymatic inhibition, some dimethoxy-containing compounds can reduce the production of pro-inflammatory cytokines like tumor necrosis factor- α (TNF- α) and interleukin- 1β (IL- 1β), which are key mediators of the inflammatory response.[18]

Emerging Neuroprotective Activities

While less explored than their other properties, dimethoxyquinoline derivatives are beginning to be investigated for their potential in treating diseases of the central nervous system.

Research into synthesizing 6,7-dimethoxyquinazolin-4(3H)-one derivatives combined with neuroactive amino acids and dipeptides is underway to explore their cerebroprotective properties against conditions like cerebral ischemia.[20] Cationic arginine-rich peptides, for example, have shown intrinsic neuroprotective properties.[20] Furthermore, a related antioxidant dihydroquinoline derivative demonstrated a significant neuroprotective effect in models of cerebral ischemia, preventing delayed neuronal cell death in the hippocampus.[21] These early findings suggest that the dimethoxyquinoline scaffold could serve as a promising starting point for the development of novel agents against neurodegenerative diseases.[20]

Conclusion and Future Directions

Dimethoxyquinoline compounds represent a remarkably versatile and privileged scaffold in modern drug discovery. Their success, particularly in oncology, is a testament to their ability to be chemically tailored to potently and selectively inhibit a wide array of high-value biological targets, from protein kinases and DNA-modifying enzymes to epigenetic regulators and cytoskeletal proteins. The demonstrated multi-mechanistic approach to cancer, combined with the ability to overcome multidrug resistance, makes this class of compounds exceptionally valuable.

While the anticancer activities are well-established, the emerging data on their antimicrobial, anti-inflammatory, and neuroprotective potential indicate that the full therapeutic scope of these compounds is yet to be realized. Future research will likely focus on:

- **Improving Selectivity:** Developing derivatives with higher selectivity for specific kinase isoforms or microbial enzymes to minimize off-target effects and improve safety profiles.[3]
- **Overcoming Resistance:** Designing next-generation compounds that can effectively target mutated enzymes that confer resistance to current therapies.[3]
- **Exploring New Targets:** Leveraging the scaffold's versatility to design inhibitors for novel targets in other therapeutic areas, such as neuroinflammation and metabolic disorders.

The continued exploration of the structure-activity relationships of dimethoxyquinoline derivatives promises to yield new and improved therapeutic agents to combat a range of

human diseases.[4]

References

- Elbadawi, M. M., Eldehna, W. M., Wang, W., Agama, K., Pommier, Y., & Abe, M. (n.d.). Discovery of 4-alkoxy-2-aryl-6,7-dimethoxyquinolines as a new class of topoisomerase I inhibitors endowed with potent in vitro anticancer activity. PMC - NIH. Retrieved from [\[Link\]](#)
- Zhang, Q. W., Ye, Z. D., Shen, C., Tie, H. X., Wang, L., & Shi, L. (2019). Synthesis of novel 6,7-dimethoxy-4-anilinoquinolines as potent c-Met inhibitors. *Journal of Enzyme Inhibition and Medicinal Chemistry*, 34(1), 124–133. Retrieved from [\[Link\]](#)
- (n.d.). Fragment Based Drug Development Based on 6,7-Dimethoxyquinazoline as a Core Scaffold. University of Texas at El Paso. Retrieved from [\[Link\]](#)
- NINGBO INNO PHARMCHEM CO.,LTD. (n.d.). 4-Chloro-6,7-dimethoxyquinoline: Key Intermediate for Anticancer Drug Synthesis and Pharmaceutical Applications. inno-pharmchem.com. Retrieved from [\[Link\]](#)
- (2019). Design, synthesis, and biological evaluation of 4-((6,7-dimethoxyquinoline-4-yl)oxy)aniline derivatives as FLT3 inhibitors for the treatment of acute myeloid leukemia. *Bioorganic & Medicinal Chemistry Letters*. Retrieved from [\[Link\]](#)
- (n.d.). SYNTHESIS AND BIOLOGICAL ACTIVITY OF A NOVEL SERIES OF 6,7-DIMETHOXYQUINAZOLINE-2,4(1H,3H)-DIONE DERIVATIVES. *Acta Poloniae Pharmaceutica*. Retrieved from [\[Link\]](#)
- RSC Publishing. (n.d.). Identification of 2,4-diamino-6,7-dimethoxyquinoline derivatives as G9a inhibitors. RSC Publishing. Retrieved from [\[Link\]](#)
- MDPI. (n.d.). Antiproliferative Efficacy of N-(3-chloro-4-fluorophenyl)-6,7-dimethoxyquinazolin-4-amine, DW-8, in Colon Cancer Cells Is Mediated by Intrinsic Apoptosis. MDPI. Retrieved from [\[Link\]](#)
- Alamia, F., La Monica, G., Bono, A., Lauria, A., Alduina, R., Gallo, A., & Martorana, A. (2024). Novel 6,7-dimethoxy-4-piperazinylquinoline derivatives as promising antibacterial agents against *Staphylococcus aureus*. IRIS UniPA. Retrieved from [\[Link\]](#)

- Zhang, Q. W., Ye, Z. D., Shen, C., Tie, H. X., Wang, L., & Shi, L. (2019). Synthesis of novel 6,7-dimethoxy-4-anilinoquinolines as potent c-Met inhibitors. Semantic Scholar. Retrieved from [\[Link\]](#)
- Sahoo, C. R., et al. (2024). Isolation, chemical characterization, antimicrobial activity, and molecular docking studies of 2,6-dimethoxy benzoquinone isolated from medicinal plant *Flacourtia jangomas*. PubMed. Retrieved from [\[Link\]](#)
- (2024). Therapeutic Potential of 1-(2-Chlorophenyl)-6,7-dimethoxy-3-methyl-3,4-dihydroisoquinoline. MDPI. Retrieved from [\[Link\]](#)
- Jin, M., et al. (2011). Anti-inflammatory activity of 6-hydroxy-2,7-dimethoxy-1,4-henantraquinone from tuberous roots of yam (*Dioscorea batatas*) through inhibition of prostaglandin D₂ and leukotriene C₄ production in mouse bone marrow-derived mast cells. PubMed. Retrieved from [\[Link\]](#)
- (n.d.). Design, synthesis, and biological evaluation of novel 5,6,7-trimethoxy quinolines as potential anticancer agents and tubulin polymerization inhibitors. NIH. Retrieved from [\[Link\]](#)
- Zhang, Q. W., et al. (2019). Synthesis of Novel 6,7-dimethoxy-4-anilinoquinolines as Potent c-Met Inhibitors. PubMed. Retrieved from [\[Link\]](#)
- Fry, D. W., et al. (1994). Tyrosine Kinase Inhibitors. 8. An Unusually Steep Structure–Activity Relationship for Analogues of 4-(3-Bromoanilino)-6,7-dimethoxyquinazoline (PD 153035), a Potent Inhibitor of the Epidermal Growth Factor Receptor. *Journal of Medicinal Chemistry*. Retrieved from [\[Link\]](#)
- (2025). Design, synthesis, and biological activity study of 6,7-dimethoxy-1,2,3,4-tetrahydroisoquinoline derivatives against multidrug resistance in Eca109/VCR cells. PubMed. Retrieved from [\[Link\]](#)
- Sahoo, C. R., et al. (2024). Isolation, chemical characterization, antimicrobial activity, and molecular docking studies of 2,6-dimethoxy benzoquinone isolated from medicinal plant *Flacourtia jangomas*. PMC - NIH. Retrieved from [\[Link\]](#)
- (2022). Synthesis and evaluation of cerebroprotective activity of novel 6,7-dimethoxyquinazolin-4(3H). *The Distant Reader*. Retrieved from [\[Link\]](#)

- (n.d.). Design, Synthesis, Antitumor and Antimicrobial Activity of Some Novel 6,7-Dimethoxyquinazoline Derivatives. ResearchGate. Retrieved from [\[Link\]](#)
- (n.d.). Synthesis, Characterization, and Anticancer Activity of New Quinazoline Derivatives against MCF-7 Cells. NIH. Retrieved from [\[Link\]](#)
- (2024). Synthesis and Anti-inflammatory Activity of Novel 2-Chloro-4-(Aryl Amino)-6, 7-Dimethoxy Quinazoline Derivatives. ResearchGate. Retrieved from [\[Link\]](#)
- (n.d.). Biological Evaluation of 8-Methoxy-2,5-dimethyl-5H-indolo[2,3-b] Quinoline as a Potential Antitumor Agent via PI3K/AKT/mTOR Signaling. MDPI. Retrieved from [\[Link\]](#)
- (n.d.). Design, synthesis, and biological evaluation of 6-methoxy-2-arylquinolines as potential P-glycoprotein inhibitors. PMC - NIH. Retrieved from [\[Link\]](#)
- Jantan, I., et al. (1997). Anti-inflammatory activity of compound D {(E)-4-(3',4'-dimethoxyphenyl)but-3-en-2-ol} isolated from Zingiber cassumunar Roxb. PubMed. Retrieved from [\[Link\]](#)
- (2025). (PDF) Biological Evaluation of 8-Methoxy-2,5-dimethyl-5H-indolo[2,3-b] Quinoline as a Potential Antitumor Agent via PI3K/AKT/mTOR Signaling. ResearchGate. Retrieved from [\[Link\]](#)
- (2025). Design, synthesis, anticancer evaluation, biological screening, and computational study of novel 6,7-dimethoxyquinazoline derivatives as VEGFR-2 inhibitors and apoptotic inducers. PubMed. Retrieved from [\[Link\]](#)
- Kamal, J. K., et al. (2015). Anti-inflammatory effect of certain dimethoxy flavones. PubMed. Retrieved from [\[Link\]](#)
- (n.d.). Isolation, chemical characterization, antimicrobial activity, and molecular docking studies of 2,6-dimethoxy benzoquinone isolated from medicinal plant Flacourtia jangomas. ResearchGate. Retrieved from [\[Link\]](#)
- (2025). Elucidating the Neuroprotective Mechanism of 5,7-Dimethoxyflavone and 5,7',4'-Trimethoxyflavone Through In Silico Target Prediction and in Memory-Impaired Mice. PubMed. Retrieved from [\[Link\]](#)

- Jantan, I., et al. (2001). Anti-inflammatory activity of 5,7-dimethoxyflavone. PubMed. Retrieved from [[Link](#)]
- De Nanteuil, G., et al. (1998). Protective effect of the antioxidant 6-ethoxy-2,2-pentamethylen-1,2-dihydroquinoline (S 33113) in models of cerebral neurodegeneration. PubMed. Retrieved from [[Link](#)]

Need Custom Synthesis?

BenchChem offers custom synthesis for rare earth carbides and specific isotopic labeling.

Email: info@benchchem.com or [Request Quote Online](#).

Sources

- 1. Discovery of 4-alkoxy-2-aryl-6,7-dimethoxyquinolines as a new class of topoisomerase I inhibitors endowed with potent in vitro anticancer activity - PMC [pmc.ncbi.nlm.nih.gov]
- 2. Design, synthesis, and biological evaluation of 4-((6,7-dimethoxyquinoline-4-yl)oxy)aniline derivatives as FLT3 inhibitors for the treatment of acute myeloid leukemia - PubMed [pubmed.ncbi.nlm.nih.gov]
- 3. pdf.benchchem.com [pdf.benchchem.com]
- 4. "Fragment Based Drug Development Based on 6,7-Dimethoxyquinazoline as a" by Cody M. Orahoske [engagedscholarship.csuohio.edu]
- 5. pdf.benchchem.com [pdf.benchchem.com]
- 6. mdpi.com [mdpi.com]
- 7. Synthesis of novel 6,7-dimethoxy-4-anilinoquinolines as potent c-Met inhibitors - PMC [pmc.ncbi.nlm.nih.gov]
- 8. Synthesis of novel 6,7-dimethoxy-4-anilinoquinolines as potent c-Met inhibitors - PubMed [pubmed.ncbi.nlm.nih.gov]
- 9. pubs.acs.org [pubs.acs.org]
- 10. Design, synthesis, and biological evaluation of novel 5,6,7-trimethoxy quinolines as potential anticancer agents and tubulin polymerization inhibitors - PMC [pmc.ncbi.nlm.nih.gov]
- 11. Identification of 2,4-diamino-6,7-dimethoxyquinoline derivatives as G9a inhibitors - PMC [pmc.ncbi.nlm.nih.gov]

- 12. Design, synthesis, and biological activity study of 6,7-dimethoxy-1,2,3,4-tetrahydroisoquinoline derivatives against multidrug resistance in Eca109/VCR cells - PubMed [pubmed.ncbi.nlm.nih.gov]
- 13. Design, synthesis, and biological evaluation of 6-methoxy-2-arylquinolines as potential P-glycoprotein inhibitors - PMC [pmc.ncbi.nlm.nih.gov]
- 14. Novel 6,7-dimethoxy-4-piperazinylquinoline derivatives as promising antibacterial agents against Staphylococcus aureus [iris.unipa.it]
- 15. ptfarm.pl [ptfarm.pl]
- 16. researchgate.net [researchgate.net]
- 17. Anti-inflammatory activity of 6-hydroxy-2,7-dimethoxy-1,4-henantraquinone from tuberous roots of yam (*Dioscorea batatas*) through inhibition of prostaglandin D₂ and leukotriene C₄ production in mouse bone marrow-derived mast cells - PubMed [pubmed.ncbi.nlm.nih.gov]
- 18. Anti-inflammatory effect of certain dimethoxy flavones - PubMed [pubmed.ncbi.nlm.nih.gov]
- 19. researchgate.net [researchgate.net]
- 20. distantreader.org [distantreader.org]
- 21. Protective effect of the antioxidant 6-ethoxy-2,2-pentamethylen-1,2-dihydroquinoline (S 33113) in models of cerebral neurodegeneration - PubMed [pubmed.ncbi.nlm.nih.gov]
- To cite this document: BenchChem. [A Comprehensive Technical Guide to the Biological Activities of Dimethoxyquinoline Compounds]. BenchChem, [2026]. [Online PDF]. Available at: [https://www.benchchem.com/product/b1419421/docs#a-comprehensive-technical-guide-to-the-biological-activities-of-dimethoxyquinoline-compounds]

Disclaimer & Data Validity:

The information provided in this document is for Research Use Only (RUO) and is strictly not intended for diagnostic or therapeutic procedures. While BenchChem strives to provide accurate protocols, we make no warranties, express or implied, regarding the fitness of this product for every specific experimental setup.

Technical Support: The protocols provided are for reference purposes. Unsure if this reagent suits your experiment?

Need Industrial/Bulk Grade? [Request Custom Synthesis Quote](#)

BenchChem

Our mission is to be the trusted global source of essential and advanced chemicals, empowering scientists and researchers to drive progress in science and industry.

Contact

Address: 3281 E Guasti Rd

Ontario, CA 91761, United States

Phone: (601) 213-4426

Email: info@benchchem.com

[Contact our Ph.D. Support Team for a compatibility check](#)