

Technical Support Center: Artifact Mitigation in GC-MS Derivatization

Author: BenchChem Technical Support Team. **Date:** May 2026

Compound of Interest

Compound Name: 2-(4-Nitrophenoxy)ethylamine
hydrochloride

CAS No.: 98395-62-1

Cat. No.: B1418339

[Get Quote](#)

Current Status: • Operational Support Tier: Level 3 (Senior Application Scientist) Topic: Reducing Artifact Formation in Silylation & Acylation Workflows

Welcome to the Advanced Derivatization Support Hub

You have reached the technical escalation desk. We do not provide generic advice here; we analyze the mechanism of failure to engineer robust solutions. Artifacts in GC-MS are not random; they are chemical signatures of specific process failures—usually related to moisture, steric hindrance, or thermal instability.

Below you will find our Active Support Tickets covering the most frequent artifact scenarios, followed by precise troubleshooting protocols.

Ticket #1: "My analyte is splitting into multiple peaks."

Diagnosis: Incomplete Derivatization or Tautomeric Shift.

If a single compound appears as two or more peaks with different retention times but similar mass spectra, the reaction has failed to lock the molecule into a single stable form.

The Mechanism

- Steric Hindrance: Bulky functional groups prevent the silylating reagent from reaching all active protons. You get a mix of mono-TMS, di-TMS, and tri-TMS derivatives.[1]
- Keto-Enol Tautomerism: Compounds with carbonyl groups (sugars, keto-acids) oscillate between ring/chain or keto/enol forms. If you silylate immediately, you "freeze" the population in its current state, creating multiple peaks for one compound (e.g.,

-glucose-TMS and

-glucose-TMS).

The Solution: Two-Step Derivatization (Methoximation)

You must "lock" the carbonyl functionality before silylation.

Protocol:

- Step A (Protection): Add Methoxyamine Hydrochloride (MeOX) in Pyridine.[2] This converts carbonyls () to oximes (), preventing ring closure and tautomerization.[2][3]
- Step B (Volatilization): Add Silylating reagent (MSTFA/BSTFA).

Decision Logic:

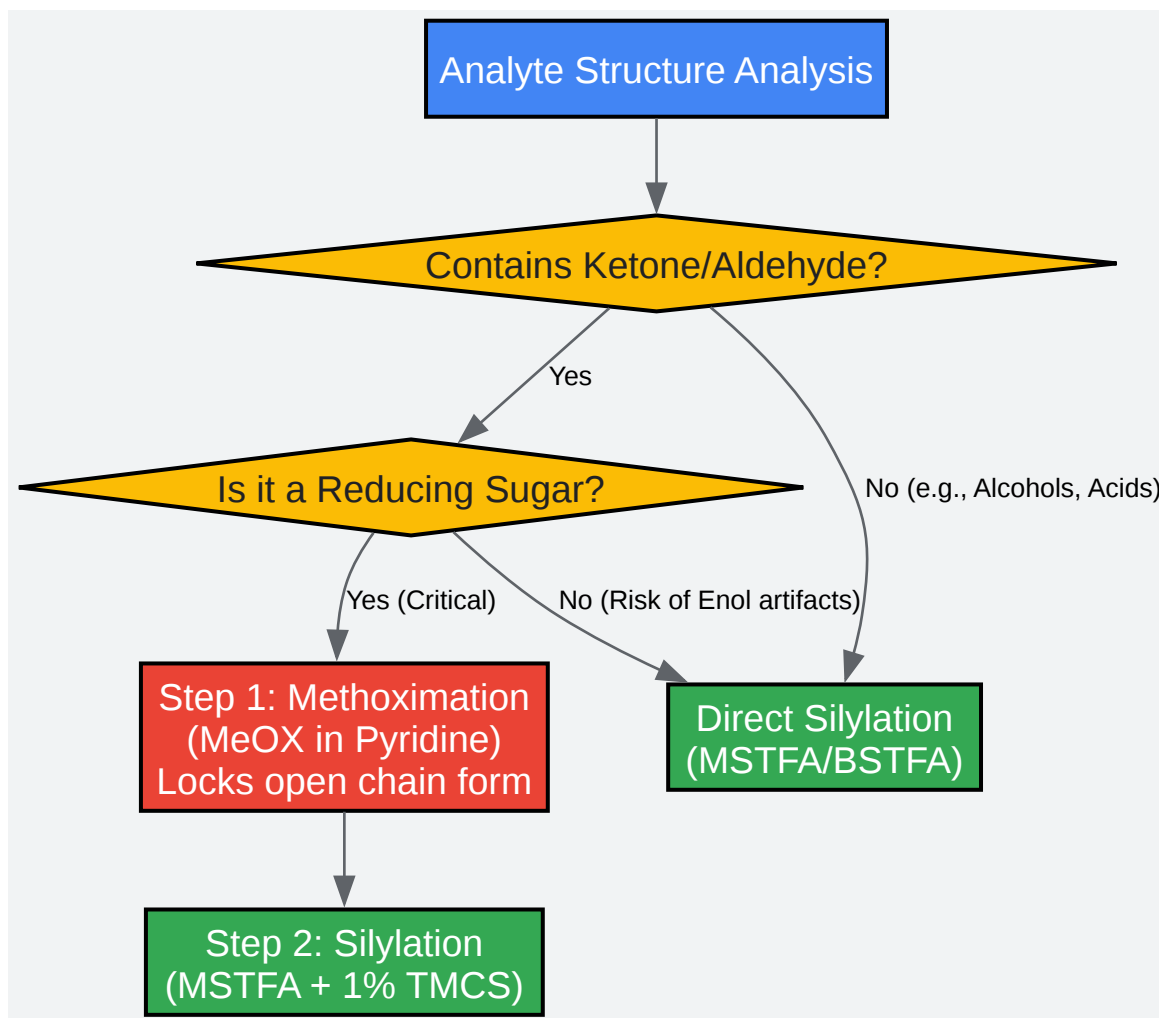

[Click to download full resolution via product page](#)

Figure 1: Decision matrix for determining when to employ methoximation to prevent tautomeric artifacts.

Ticket #2: "I see 'Ghost Peaks' or my derivative yield is low."

Diagnosis: Hydrolysis (Moisture Contamination).

TMS derivatives are hydrolytically unstable. Trace water acts as a nucleophile, cleaving the Si-O bond and returning the analyte to its underivatized (non-volatile) state, or forming hexamethyldisiloxane (HMDSO) artifacts.

The Mechanism

The byproduct (

) dimerizes to form siloxane peaks that clutter the chromatogram.

The Solution: Chemical Drying & Scavenging

Physical drying (nitrogen blow-down) is often insufficient because pyridine is hygroscopic.

Protocol:

- Azeotropic Drying: If your sample is aqueous, dry it down, then add 50 μ L of benzene or toluene and dry again. This pulls residual water out.
- Reagent Scavenging: Use reagents with high silylating power that consume water.
 - Standard: BSTFA (N,O-Bis(trimethylsilyl)trifluoroacetamide).[1][4][5][6]
 - Aggressive: BSTFA + 1% TMCS (Trimethylchlorosilane).[7] TMCS acts as a catalyst and a water scavenger.

Comparison of Silylating Power:

Reagent	Strength	Volatility	Best Use Case	Artifact Risk
MSTFA	High	Very High	Metabolomics, early eluting peaks	Low (Byproducts are volatile)
BSTFA	High	High	General purpose (Drugs, Steroids)	Medium (Byproducts less volatile)
BSTFA + 1% TMCS	Very High	High	Sterically hindered alcohols/amines	High (If moisture is present, HCl forms)
TMSI	Extreme	Low	Sugars, steroids with -OH	High (Hard to remove reagent)

Ticket #3: "My peaks are tailing or disappearing in the inlet."

Diagnosis: Thermal Degradation & Active Sites.

The GC inlet is a reactor. If you inject a thermally labile derivative (like a carbamate or certain amino acids) into a 280°C dirty liner, it will degrade before reaching the column.

The Mechanism

- **Liner Activity:** Silanol groups (-Si-OH) on glass wool or the liner wall hydrogen bond with the analyte, causing tailing or catalytic breakdown.
- **Thermal Shock:** Sudden heating causes bond cleavage (e.g., loss of CO₂ from carbamates).

The Solution: Inlet Deactivation

- **Liner Selection:** Use Ultra-Inert liners with deactivated glass wool. Avoid unpacked straight tubes for splitless injections (poor heat transfer).
- **Pressure Pulse Injection:** Increase inlet pressure (e.g., 30 psi) for 0.5 min during injection. This pushes the sample onto the column faster, reducing residence time in the hot inlet.
- **Temperature Ramp:** If degradation persists, use a PTV (Programmed Temperature Vaporizer) inlet. Inject cold (40°C), then ramp rapidly to volatilize.

Ticket #4: "I have unexpected peaks at specific masses (m/z 73, 147, 207, 281)."

Diagnosis: Septum Bleed or Column Bleed (Polysiloxanes).

These are not sample artifacts; they are system artifacts.

- m/z 73:

(The TMS group itself).

- m/z 207, 281: Cyclic siloxanes (D3, D4) from column stationary phase degradation or septum off-gassing.

Troubleshooting:

- Check the Septum: Is it cored? Replace it. Use "High Temp" septa.
- Check the Reagent: Old BSTFA hydrolyzes to form siloxanes. Inject a blank (solvent + reagent only). If you see the peaks, buy new reagent.

Master Protocol: The "Gold Standard" Metabolomics Workflow

Designed to minimize all above artifacts for complex biological samples.

Reagents Required:

- Methoxyamine HCl (20 mg/mL in Pyridine)[6]
- MSTFA + 1% TMCS[7]
- Internal Standard (e.g., Ribitol)

Step-by-Step:

- Lyophilization: Dry sample completely.
- Secondary Drying: Add 50 μ L acetonitrile, vortex, and dry under
to remove trace water azeotropically.
- Methoximation:
 - Add 80 μ L MeOX/Pyridine.
 - Incubate at 37°C for 90 mins. (Do not overheat; causes degradation).
- Silylation:
 - Add 80 μ L MSTFA + 1% TMCS.
 - Incubate at 37°C for 30 mins.

- Settling: Centrifuge at 14,000 rpm for 2 mins to precipitate any salts (ammonium chloride).
- Injection: Transfer supernatant to a vial with a glass insert. Inject within 24 hours.

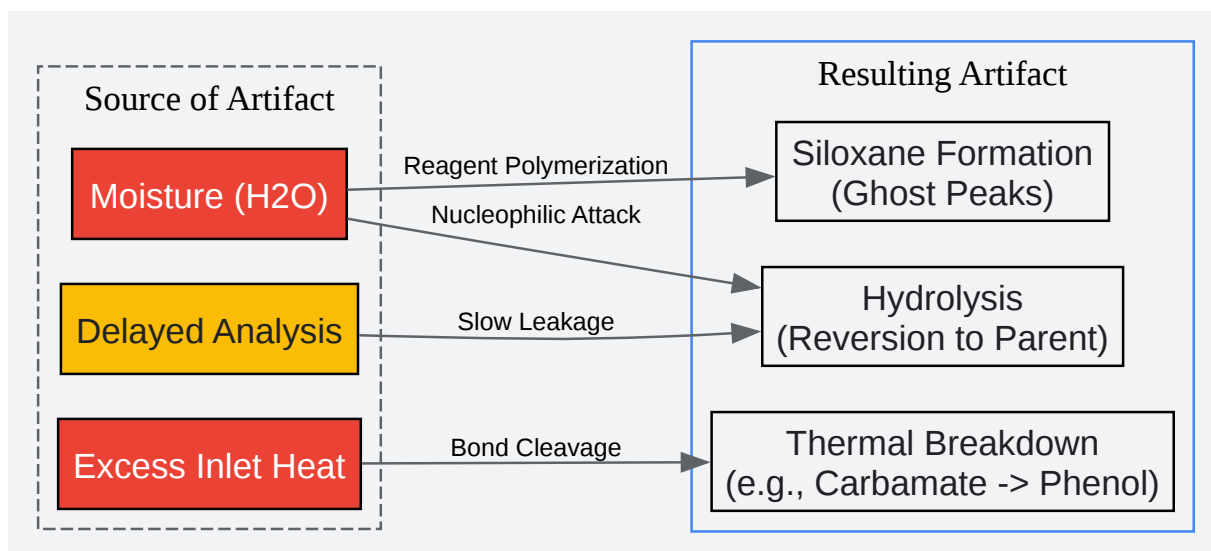

[Click to download full resolution via product page](#)

Figure 2: Causal pathways for common GC-MS artifacts.

References

- Little, J. L. (1999).^{[5][8][9]} Artifacts in trimethylsilyl derivatization reactions and ways to avoid them. *Journal of Chromatography A*, 844(1-2), 1-22. [Link](#)
- Fiehn, O. (2016). *Metabolomics by Gas Chromatography-Mass Spectrometry: Combined Targeted and Untargeted Profiling*. *Current Protocols in Molecular Biology*. [Link](#)
- Knapp, D. R. (1979). *Handbook of Analytical Derivatization Reactions*. John Wiley & Sons. (Canonical Text).
- Schummer, C., et al. (2009). Comparison of MTBSTFA and BSTFA in derivatization reactions of polar compounds prior to GC/MS analysis. *Talanta*, 77(4), 1473-1482. [Link](#)
- Kanani, H., et al. (2008). Corrections for temporal scaling and reagent-derived artifacts in GC-MS-based metabolomics. *Analytical Biochemistry*, 381(1), 17-23. [Link](#)

Need Custom Synthesis?

BenchChem offers custom synthesis for rare earth carbides and specific isotopic labeling.

Email: info@benchchem.com or [Request Quote Online](#).

Sources

- 1. Formation of multiple trimethylsilyl derivatives in the derivatization of 17alpha-ethinylestradiol with BSTFA or MSTFA followed by gas chromatography-mass spectrometry determination - PubMed [pubmed.ncbi.nlm.nih.gov]
- 2. Derivatization of metabolites for GC-MS via methoximation+silylation – The Bumbling Biochemist [thebumblingbiochemist.com]
- 3. Optimized Workflow for On-Line Derivatization for Targeted Metabolomics Approach by Gas Chromatography-Mass Spectrometry - PMC [pmc.ncbi.nlm.nih.gov]
- 4. littlesandsailing.wordpress.com [littlesandsailing.wordpress.com]
- 5. sigmaaldrich.com [sigmaaldrich.com]
- 6. Drying Enhances Signal Intensities for Global GC–MS Metabolomics - PMC [pmc.ncbi.nlm.nih.gov]
- 7. palsystem.com [palsystem.com]
- 8. mzinterpretation.com [mzinterpretation.com]
- 9. Will excess BSTFA in GCMS cause problems? - Chromatography Forum [chromforum.org]
- To cite this document: BenchChem. [Technical Support Center: Artifact Mitigation in GC-MS Derivatization]. BenchChem, [2026]. [Online PDF]. Available at: [<https://www.benchchem.com/product/b1418339/docs#technical-support-center-artifact-mitigation-in-gc-ms-derivatization>]

Disclaimer & Data Validity:

The information provided in this document is for Research Use Only (RUO) and is strictly not intended for diagnostic or therapeutic procedures. While BenchChem strives to provide accurate protocols, we make no warranties, express or implied, regarding the fitness of this product for every specific experimental setup.

Technical Support: The protocols provided are for reference purposes. Unsure if this reagent suits your experiment?

Need Industrial/Bulk Grade? [Request Custom Synthesis Quote](#)

BenchChem

Our mission is to be the trusted global source of essential and advanced chemicals, empowering scientists and researchers to drive progress in science and industry.

Contact

Address: 3281 E Guasti Rd
Ontario, CA 91761, United States
Phone: (601) 213-4426
Email: info@benchchem.com

[Contact our Ph.D. Support Team for a compatibility check](#)