

Technical Monograph: 2-Chloro-3-nitropyridin-4-ol

Author: BenchChem Technical Support Team. **Date:** May 2026

Compound of Interest

Compound Name: 2-Chloro-3-nitropyridin-4-OL

CAS No.: 629655-23-8

Cat. No.: B1418837

[Get Quote](#)

Chemical Identity & Nomenclature

2-Chloro-3-nitropyridin-4-ol is a tri-substituted pyridine derivative characterized by orthogonal reactivity patterns, making it a "privileged scaffold" for constructing bicyclic heterocycles (e.g., imidazopyridines, pyrrolopyridines).

Core Identifiers

Property	Detail
IUPAC Name	2-Chloro-3-nitropyridin-4-ol
Preferred Tautomeric Name	2-Chloro-3-nitro-1H-pyridin-4-one
CAS Registry Number	629655-23-8
Molecular Formula	C ₅ H ₃ ClN ₂ O ₃
Molecular Weight	174.54 g/mol
SMILES	<chem>OC1=C(N(=O)=O)C(Cl)=NC=C1</chem>

Tautomerism: The "Ol" vs. "One" Dichotomy

In solution and solid states, 4-hydroxypyridines exist in dynamic equilibrium with their 4-pyridone tautomers. For this specific compound, the electron-withdrawing nitro group at position 3 increases the acidity of the hydroxyl proton, potentially influencing the equilibrium. However, in polar solvents (DMSO, MeOH) and the solid phase, the pyridone (NH) form is generally dominant due to lattice energy stabilization and solvation effects.

- Implication for Synthesis: When using this compound as a nucleophile (e.g., alkylation), the reaction can occur at the oxygen (O-alkylation) or the nitrogen (N-alkylation), depending on the base and solvent used.

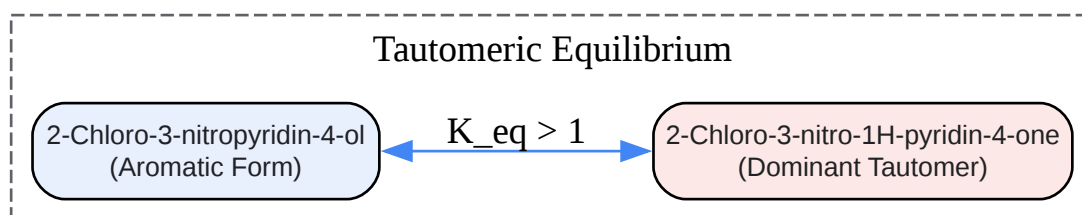

[Click to download full resolution via product page](#)

Figure 1: Tautomeric equilibrium between the hydroxypyridine and pyridone forms. The pyridone form typically predominates in polar media.

Synthesis & Production

The most robust synthetic route to **2-Chloro-3-nitropyridin-4-ol** utilizes regioselective nucleophilic aromatic substitution (S_NAr) starting from 2,4-dichloro-3-nitropyridine.

Reaction Mechanism & Regioselectivity

The starting material, 2,4-dichloro-3-nitropyridine, possesses two electrophilic sites (C2 and C4).

- Activation: Both positions are activated by the ring nitrogen and the electron-withdrawing nitro group at C3.

- Selectivity: The C4 position is generally more reactive toward nucleophiles (like water or hydroxide) due to the "para-like" activation from the pyridine nitrogen and the specific steric/electronic environment created by the adjacent nitro group. The C2 position is flanked by the ring nitrogen and the nitro group, creating a "pocket" that can sterically hinder the approach of nucleophiles compared to the more exposed C4 position.

Validated Experimental Protocol

Objective: Hydrolysis of 2,4-dichloro-3-nitropyridine to **2-chloro-3-nitropyridin-4-ol**.

Reagents:

- 2,4-Dichloro-3-nitropyridine (1.0 eq)
- Sodium Acetate (NaOAc) (2.0 - 2.5 eq)
- Solvent: N,N-Dimethylformamide (DMF) or Water/Dioxane mixtures.

Step-by-Step Methodology:

- Preparation: Charge a round-bottom flask with 2,4-dichloro-3-nitropyridine (e.g., 100 g) and DMF (500 mL).
- Activation: Add anhydrous Sodium Acetate (102.4 g). The use of acetate acts as a mild base and nucleophile, initially forming an acetoxy intermediate which rapidly hydrolyzes, or buffering the generation of HCl.
- Reaction: Heat the mixture to 120–125°C. Maintain this temperature for 2–3 hours. Monitor by HPLC/TLC for the disappearance of the starting dichloro species.
- Work-up:
 - Cool the reaction mass to room temperature (25–30°C).
 - Concentrate the solvent under reduced pressure (vacuum distillation) if DMF is used.
 - Quench the residue with saturated ammonium chloride solution and extract with dichloromethane (DCM) or Ethyl Acetate to remove non-polar impurities (though the

product is amphoteric/polar).

- Alternative Isolation: For high purity, dilute the reaction mixture with water and adjust pH to ~3-4 with dilute HCl to precipitate the pyridone/pyridinol product.
- Purification: Recrystallize from Toluene or Ethanol/Water if necessary.
- Yield: Typical yields range from 85% to 95%.

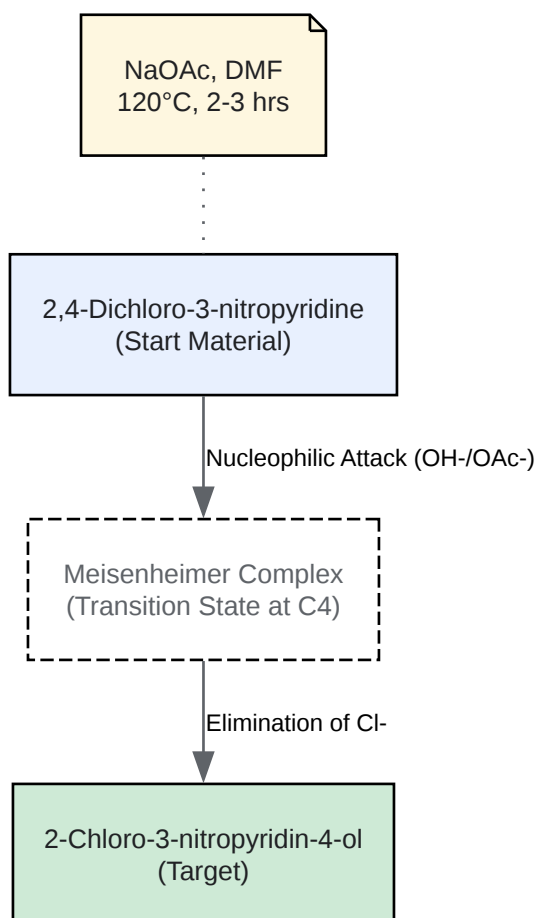

[Click to download full resolution via product page](#)

Figure 2: Synthetic pathway illustrating the regioselective hydrolysis at the C4 position.

Applications in Drug Discovery

2-Chloro-3-nitropyridin-4-ol serves as a high-value scaffold because it allows for orthogonal functionalization. Medicinal chemists can modify the molecule sequentially at three distinct positions:

- C4-OH: Can be alkylated (ether formation) or converted to a leaving group (Cl, Br, OTf) for cross-coupling.
- C2-Cl: Available for S_NAr with amines or Suzuki-Miyaura coupling.
- C3-NO₂: Precursor to an amine (-NH₂), enabling cyclization reactions.

Case Study: JAK Inhibitor Synthesis (Baricitinib Analogs)

This scaffold is frequently cited in the synthesis of Janus Kinase (JAK) inhibitors. A common workflow involves protecting the C4-hydroxyl group to direct subsequent chemistry to the C2 position.

Workflow:

- Protection: React **2-chloro-3-nitropyridin-4-ol** with SEM-Cl (2-(Trimethylsilyl)ethoxymethyl chloride) to form 2-chloro-3-nitro-4-((2-(trimethylsilyl)ethoxy)methoxy)pyridine. This protects the oxygen and improves solubility.
- S_NAr: Displace the C2-chloride with a functionalized amine (e.g., a pyrazole or amine linker).
- Reduction & Cyclization: Reduce the C3-nitro group to an amine. The resulting diamine (C3-NH₂, C2-NH-R) can be cyclized with orthoformate or phosgene to form imidazopyridines or triazolopyridines.

Key Derivatives

Derivative Class	Reaction Type	Application
4-Alkoxy-2-chloropyridines	O-Alkylation	Building blocks for ether-linked kinase inhibitors.
2-Amino-3-nitropyridin-4-ols	S _N Ar at C2	Precursors for Hsp90 or Topoisomerase inhibitors.
Imidazo[4,5-b]pyridines	Reduction + Cyclization	Core scaffold for various anti-cancer agents.

Safety & Handling (MSDS Highlights)

While specific toxicological data for this intermediate is limited compared to commercial drugs, it shares hazard profiles with similar nitropyridines.

- GHS Classification:
 - Skin Irritation: Category 2 (H315)
 - Eye Irritation: Category 2A (H319)
 - STOT-SE: Category 3 (Respiratory Irritation) (H335)
- Handling Precautions:
 - Engineering Controls: Use only in a chemical fume hood to avoid inhalation of dust/vapors.
 - PPE: Nitrile gloves, safety goggles, and lab coat are mandatory.
 - Storage: Store in a cool, dry place under inert atmosphere (Argon/Nitrogen) if possible, as nitropyridines can be light-sensitive.

References

- Google Patents. (2010). WO2010089773A2 - Process for preparation of nitropyridine derivatives.
- PubChem. (2025).[1] 2-Chloro-3-nitropyridine (Related Compound Data). National Library of Medicine. Retrieved from [\[Link\]](#)

Need Custom Synthesis?

BenchChem offers custom synthesis for rare earth carbides and specific isotopic labeling.

Email: info@benchchem.com or [Request Quote Online](#).

Sources

- [1. 2-Chloro-5-nitropyridine | C5H3ClN2O2 | CID 78308 - PubChem](#)
[\[pubchem.ncbi.nlm.nih.gov\]](https://pubchem.ncbi.nlm.nih.gov)
- To cite this document: BenchChem. [Technical Monograph: 2-Chloro-3-nitropyridin-4-ol]. BenchChem, [2026]. [Online PDF]. Available at:
[\[https://www.benchchem.com/product/b1418837/docs#technical-monograph-2-chloro-3-nitropyridin-4-ol\]](https://www.benchchem.com/product/b1418837/docs#technical-monograph-2-chloro-3-nitropyridin-4-ol)

Disclaimer & Data Validity:

The information provided in this document is for Research Use Only (RUO) and is strictly not intended for diagnostic or therapeutic procedures. While BenchChem strives to provide accurate protocols, we make no warranties, express or implied, regarding the fitness of this product for every specific experimental setup.

Technical Support: The protocols provided are for reference purposes. Unsure if this reagent suits your experiment?

Need Industrial/Bulk Grade? [Request Custom Synthesis Quote](#)

BenchChem

Our mission is to be the trusted global source of essential and advanced chemicals, empowering scientists and researchers to drive progress in science and industry.

Contact

Address: 3281 E Guasti Rd
Ontario, CA 91761, United States
Phone: (601) 213-4426
Email: info@benchchem.com

[Contact our Ph.D. Support Team for a compatibility check](#)