

# Application Notes & Protocols: The Conrad-Limpach Synthesis of Substituted Quinolines

**Author:** BenchChem Technical Support Team. **Date:** May 2026

## Compound of Interest

Compound Name: 5-Methoxy-4-methylquinoline

CAS No.: 144147-05-7

Cat. No.: B1418731

[Get Quote](#)

## Introduction

The quinoline scaffold is a cornerstone in medicinal chemistry and drug development, forming the core of numerous therapeutic agents. Molecules incorporating this nitrogen-containing heterocycle exhibit a vast range of biological activities, including antimalarial, antibacterial, and anticancer properties.<sup>[1][2]</sup> The Conrad-Limpach synthesis, first reported by Max Conrad and Leonhard Limpach in 1887, remains a powerful and relevant method for constructing substituted 4-hydroxyquinolines (which exist in equilibrium with their quinolin-4-one tautomers).<sup>[3][4][5]</sup>

This document provides an in-depth guide for researchers and drug development professionals, moving beyond a simple recitation of steps to explain the underlying principles, critical parameters, and practical considerations necessary for the successful application of this classic reaction.

## Theoretical Framework: Mechanism and Regioselectivity

The Conrad-Limpach synthesis is fundamentally a two-stage process involving the condensation of an aromatic amine (an aniline) with a  $\beta$ -ketoester, followed by a high-temperature thermal cyclization.[4][6]

#### Stage 1: Enamine Formation (Kinetic Control)

The reaction is initiated by the nucleophilic attack of the aniline's amino group on the electrophilic ketone carbonyl of the  $\beta$ -ketoester.[3][5] This pathway is kinetically favored and typically conducted at moderate temperatures (room temperature to  $\sim 100$  °C) to yield a stable  $\beta$ -aminoacrylate intermediate (an enamine).[3][7] An acid catalyst is often employed to facilitate this condensation.[3]

#### Stage 2: Thermal Cyclization

The crucial ring-forming step requires significant thermal energy. The enamine intermediate is heated to temperatures around  $250$  °C in a high-boiling, inert solvent.[3][4] This high temperature facilitates an electrocyclic ring closure onto the aromatic ring, which is the rate-determining step of the synthesis.[3] This step temporarily disrupts the aromaticity of the aniline ring, contributing to the high energy barrier.[1] Subsequent elimination of an alcohol molecule (from the original ester) and tautomerization yields the final 4-hydroxyquinoline product.[3][5]

The final product is often represented as the 4-hydroxyquinoline (enol form), but it is widely believed that the quinolin-4(1H)-one (keto form) is the predominant tautomer.[3]

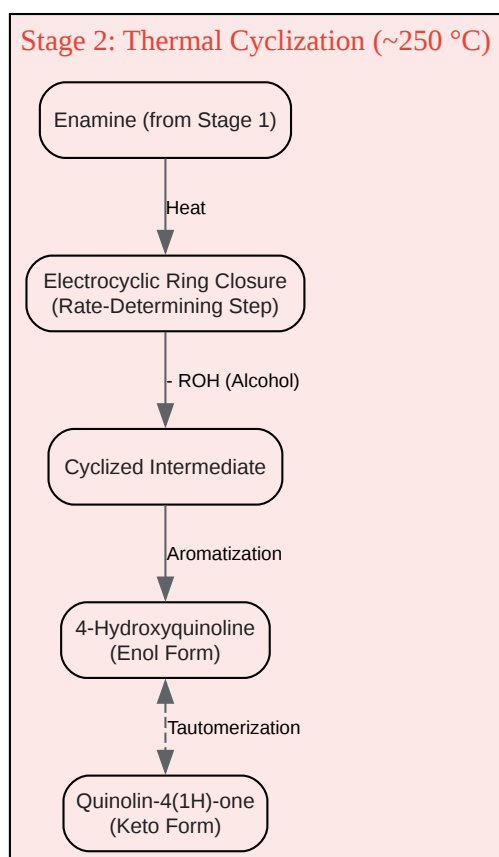
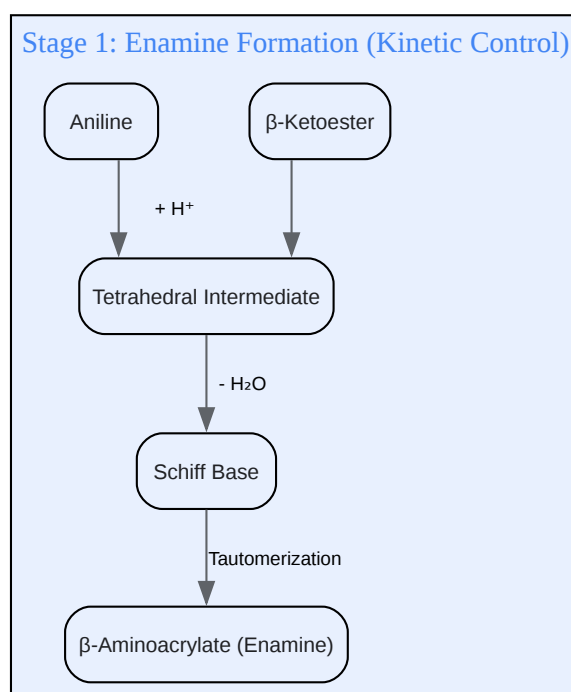

[Click to download full resolution via product page](#)

Figure 1: Reaction mechanism of the Conrad-Limpach synthesis.

## The Decisive Role of Temperature: Conrad-Limpach vs. Knorr Synthesis

A critical aspect of this chemistry is the regioselectivity governed by reaction temperature during the initial condensation. The  $\beta$ -ketoester possesses two electrophilic sites: the ketone (more reactive) and the ester (less reactive).

- **Conrad-Limpach Pathway (Kinetic Control):** At lower temperatures (e.g., room temperature), the reaction is under kinetic control, and the aniline preferentially attacks the more reactive ketone carbonyl, leading to the enamine intermediate required for 4-hydroxyquinoline synthesis.[3][8]
- **Knorr Pathway (Thermodynamic Control):** At higher temperatures (e.g.,  $\sim 140^\circ\text{C}$ ), the reaction becomes reversible.[8] While the attack on the ketone is faster, the reverse reaction is also fast. The attack on the less reactive ester carbonyl is slower but forms a more stable  $\beta$ -keto anilide intermediate.[8] Under these thermodynamically controlled conditions, this anilide accumulates and, upon cyclization, yields the isomeric 2-hydroxyquinoline.[3][7]

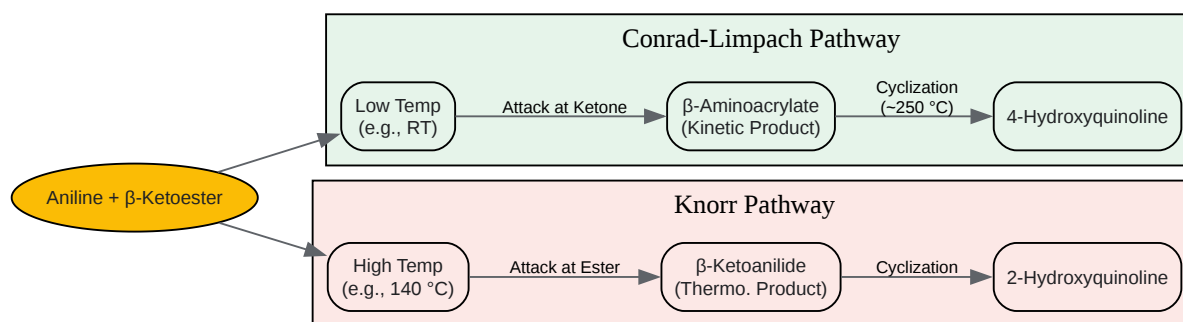

[Click to download full resolution via product page](#)

Figure 2: Temperature-dependent regioselectivity determines the product isomer.

## Experimental Protocols and Workflow

The following protocols provide a generalized yet detailed methodology. Researchers should optimize conditions based on their specific substrates.

## Workflow Overview

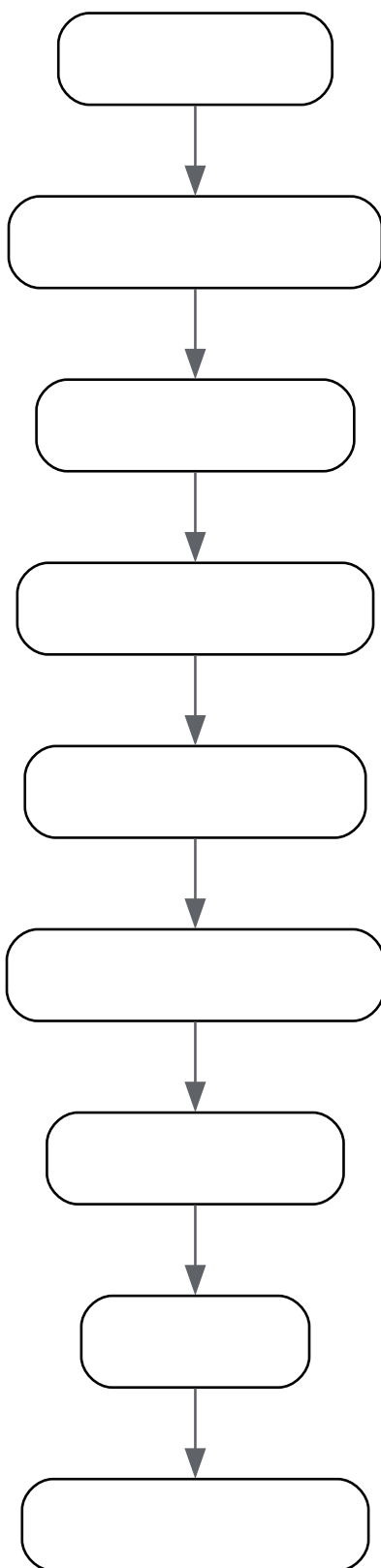

[Click to download full resolution via product page](#)

Figure 3: General experimental workflow for the Conrad-Limpach synthesis.

## Part A: Synthesis of Enamine Intermediate (Ethyl 3-anilinobut-2-enoate)

Materials:

- Aniline (1.0 eq)
- Ethyl acetoacetate (1.0 eq)
- Toluene or Ethanol
- Glacial acetic acid (catalytic amount, ~0.1 eq)
- Round-bottom flask with Dean-Stark trap and condenser

Procedure:

- To a round-bottom flask, add aniline (1.0 eq), ethyl acetoacetate (1.0 eq), and the chosen solvent (e.g., toluene).
- Add a catalytic amount of glacial acetic acid.
- Fit the flask with a Dean-Stark trap and reflux condenser.
- Heat the mixture to reflux for 2-4 hours, collecting the water generated during the condensation in the trap.
- Once the theoretical amount of water has been collected, cool the reaction mixture to room temperature.
- Remove the solvent under reduced pressure using a rotary evaporator. The resulting oil or solid is the crude enamine intermediate. In many cases, this crude product is of sufficient purity to be carried directly into the next step without further purification.[9]

## Part B: Thermal Cyclization to 4-hydroxy-2-methylquinoline

Materials:

- Crude Ethyl 3-anilinobut-2-enoate (from Part A)
- High-boiling solvent (e.g., Diphenyl ether, Mineral Oil, Dowtherm A)
- High-temperature thermometer
- Three-neck flask with mechanical stirrer and condenser
- Hexanes or petroleum ether for washing

Procedure:

- In a three-neck flask equipped with a mechanical stirrer, condenser, and a high-temperature thermometer, add the high-boiling solvent (e.g., diphenyl ether).
- Heat the solvent with vigorous stirring to ~250 °C. CAUTION: This step involves extremely high temperatures and should be performed in a well-ventilated fume hood with appropriate personal protective equipment.
- Once the solvent has reached a stable temperature of 250 °C, add the crude enamine intermediate from Part A dropwise or in small portions over 20-30 minutes.
- Maintain the reaction temperature at 250 °C for an additional 30 minutes after the addition is complete.
- Remove the heat source and allow the reaction mixture to cool slowly to below 100 °C.
- While still warm, pour the mixture into a beaker containing a large volume of a non-polar solvent like hexanes or petroleum ether to precipitate the product and dilute the high-boiling solvent.
- Stir the resulting slurry and allow it to cool completely to room temperature or in an ice bath to maximize precipitation.
- Collect the solid product by vacuum filtration.
- Wash the filter cake thoroughly with hexanes or petroleum ether to remove residual high-boiling solvent.

- Purify the crude product by recrystallization from a suitable solvent (e.g., ethanol, acetic acid, or DMF).

## Critical Parameters and Optimization Strategies

### Solvent Selection for Thermal Cyclization

The choice of solvent for the high-temperature cyclization is arguably the most critical parameter for achieving high yields.<sup>[3]</sup> The solvent must be inert and have a boiling point at or above the required reaction temperature (~250 °C). While traditional solvents are effective, they have drawbacks such as cost, odor, or inconvenient physical properties (e.g., mineral oil's viscosity, diphenyl ether being a solid at room temperature).<sup>[1]</sup> Recent studies have explored alternatives.<sup>[1]</sup>

Solvent	Boiling Point (°C)	Typical Yield (%)	Notes
Mineral Oil	> 275	Moderate to High	Inexpensive but difficult to handle and remove.[1]
Diphenyl Ether	259	High	Effective, but solid at room temp with an unpleasant odor.[1]
Dowtherm A	257	High	Liquid at room temp, but expensive with an unpleasant odor.[1]
Ethyl Benzoate	212	Moderate (~25%)	Lower yield due to lower boiling point.[1]
iso-Butyl Benzoate	247	High (~66%)	Good yield but significantly more expensive.[1]
1,2,4-Trichlorobenzene	214	Moderate	Inexpensive alternative.[1]
2,6-di-tert-butylphenol	265	High (~65%)	Excellent alternative; clean reaction, no odor, less expensive than Dowtherm A.[1]

Table 1: Comparison of solvents for the Conrad-Limpach thermal cyclization. Data adapted from Pratt, et al.[1]

Insight: The data clearly shows a correlation between higher boiling points and improved yields, up to a plateau around 65-70%. [1] For large-scale synthesis, 2,6-di-tert-butylphenol presents a compelling, user-friendly alternative to traditional solvents.[1]

## Troubleshooting Guide

Problem	Possible Cause(s)	Recommended Solution(s)
Low Yield in Cyclization	1. Reaction temperature was too low. 2. Reaction time was insufficient. 3. Inappropriate solvent choice.	1. Ensure accurate temperature monitoring at 250 °C. 2. Increase reaction time incrementally. 3. Switch to a higher-boiling solvent (see Table 1).
Formation of Knorr Product (2-Hydroxyquinoline)	The initial enamine formation step was conducted at too high a temperature, favoring the thermodynamic anilide product.	Maintain a lower temperature (RT to 100 °C) during the condensation of the aniline and $\beta$ -ketoester.
Tarring/Decomposition	1. Cyclization temperature was excessively high. 2. Presence of impurities in the enamine intermediate. 3. Prolonged reaction time at high temperature.	1. Do not exceed 260 °C. 2. Consider a simple purification (e.g., short-path distillation) of the enamine if it is particularly unstable. 3. Optimize the reaction time to find the point of maximum conversion before decomposition becomes significant.
Product Fails to Precipitate	The product is soluble in the hexanes/high-boiling solvent mixture.	1. Use a larger volume of the precipitating solvent (e.g., hexanes). 2. Ensure the mixture is thoroughly cooled in an ice bath. 3. If the product is an oil, attempt to triturate with the non-polar solvent to induce crystallization.

## References

- Conrad–Limpach synthesis. (URL: )

- A Survey of Solvents for the Conrad-Limpach Synthesis of 4-Hydroxyquinolones. (URL: [\[Link\]](#))
- Conrad-Limpach Synthesis. SynArchive. (URL: )
- Synthesis of 4-Hydroxyquinolines as Potential Cytotoxic Agents. MDPI. (URL: [\[Link\]](#))
- Synthesis, Reactions and Medicinal Uses of Quinoline. Pharmaguideline. (URL: )
- Conrad-Limpach Quinoline Synthesis: A. General Description of The Reaction. Scribd. (URL: [\[Link\]](#))
- Recent Advances in Metal-Free Quinoline Synthesis. PMC - NIH. (URL: [\[Link\]](#))
- Conrad-Limpach Reaction. (URL: [\[Link\]](#))
- Quinolin-4-ones: Methods of Synthesis and Application in Medicine. MDPI. (URL: [\[Link\]](#))
- Conrad-Limpach reaction. ResearchGate. (URL: [\[Link\]](#))
- Mechanism of Conrad–Limpach synthesis of 4-hydroxyquinolines/ quinolin-4(1H)-ones. ResearchGate. (URL: [\[Link\]](#))
- Conrad-Limpach-Chinolinsynthese. Wikipedia. (URL: [\[Link\]](#))
- Conrad-limpach-knorr synthesis of Quinolone. YouTube. (URL: [\[Link\]](#))
- Lecture 43 | Conrad-Limpach Reaction | Name Reactions | Organic Chemistry. YouTube. (URL: [\[Link\]](#))

#### **Need Custom Synthesis?**

BenchChem offers custom synthesis for rare earth carbides and specific isotopic labeling.

Email: [info@benchchem.com](mailto:info@benchchem.com) or [Request Quote Online](#).

## Sources

- [1. A Survey of Solvents for the Conrad-Limpach Synthesis of 4-Hydroxyquinolones - PMC \[pmc.ncbi.nlm.nih.gov\]](#)
- [2. researchgate.net \[researchgate.net\]](#)
- [3. Conrad–Limpach synthesis - Wikipedia \[en.wikipedia.org\]](#)
- [4. synarchive.com \[synarchive.com\]](#)
- [5. Conrad-Limpach-Chinolinsynthese – Wikipedia \[de.wikipedia.org\]](#)
- [6. Conrad-Limpach Reaction \(Chapter 17\) - Name Reactions in Organic Synthesis \[resolve.cambridge.org\]](#)
- [7. Synthesis, Reactions and Medicinal Uses of Quinoline | Pharmaguideline \[pharmaguideline.com\]](#)
- [8. m.youtube.com \[m.youtube.com\]](#)
- [9. scribd.com \[scribd.com\]](#)
- To cite this document: BenchChem. [Application Notes & Protocols: The Conrad-Limpach Synthesis of Substituted Quinolines]. BenchChem, [2026]. [Online PDF]. Available at: [\[https://www.benchchem.com/product/b1418731/docs#application-notes-protocols-the-conrad-limpach-synthesis-of-substituted-quinolines\]](https://www.benchchem.com/product/b1418731/docs#application-notes-protocols-the-conrad-limpach-synthesis-of-substituted-quinolines)

---

#### Disclaimer & Data Validity:

The information provided in this document is for Research Use Only (RUO) and is strictly not intended for diagnostic or therapeutic procedures. While BenchChem strives to provide accurate protocols, we make no warranties, express or implied, regarding the fitness of this product for every specific experimental setup.

**Technical Support:** The protocols provided are for reference purposes. Unsure if this reagent suits your experiment?

**Need Industrial/Bulk Grade?** [Request Custom Synthesis Quote](#)

# BenchChem

Our mission is to be the trusted global source of essential and advanced chemicals, empowering scientists and researchers to drive progress in science and industry.

## Contact

Address: 3281 E Guasti Rd

Ontario, CA 91761, United States

Phone: (601) 213-4426

Email: [info@benchchem.com](mailto:info@benchchem.com)

[Contact our Ph.D. Support Team for a compatibility check](#)