

Potential Applications of Substituted Triarylamines in Materials Science: A Technical Guide

Author: BenchChem Technical Support Team. **Date:** April 2026

Compound of Interest

Compound Name:	<i>3-Iodo-N,N-bis(4-methylphenyl)aniline</i>
CAS No.:	928032-78-4
Cat. No.:	B14179613

[Get Quote](#)

Executive Summary

Substituted triarylamines (TAAs) represent a cornerstone class of hole-transporting materials (HTMs) in organic electronics and optoelectronics. Their utility stems from a unique structural duality: the nitrogen center provides a stable, reversible redox couple (N/N⁺) for charge transport, while the "propeller-like" geometry of the aryl rings prevents π - π stacking, facilitating the formation of stable, amorphous films essential for device longevity.

This guide explores the causal relationship between TAA substitution patterns and their performance in Perovskite Solar Cells (PSCs), Organic Light-Emitting Diodes (OLEDs), and emerging bio-imaging modalities.

Fundamental Chemistry & Structure-Property Relationships

The Propeller Geometry & Amorphous Stability

Unlike planar polyaromatics (e.g., pentacene) that crystallize readily, the steric repulsion between ortho-hydrogens in TAAs forces the aryl rings to twist (approx. 40–50°). This frustration prevents crystallization, allowing TAAs to form pinhole-free amorphous films via solution processing—a critical requirement for preventing leakage currents in OLEDs and PSCs.

Electronic Tuning via Substitution

The Highest Occupied Molecular Orbital (HOMO) of TAAs is localized on the nitrogen lone pair and the π -system of the aryl rings.

- **Electron-Donating Groups (EDGs):** Substituents like methoxy (-OMe) or alkylamines raise the HOMO level, facilitating hole injection from anodes (e.g., ITO) or perovskites.
- **Electron-Withdrawing Groups (EWGs):** Substituents like fluorine (-F) or cyano (-CN) lower the HOMO level, increasing oxidative stability and open-circuit voltage () in solar cells.

Visualization: Structure-Property Logic

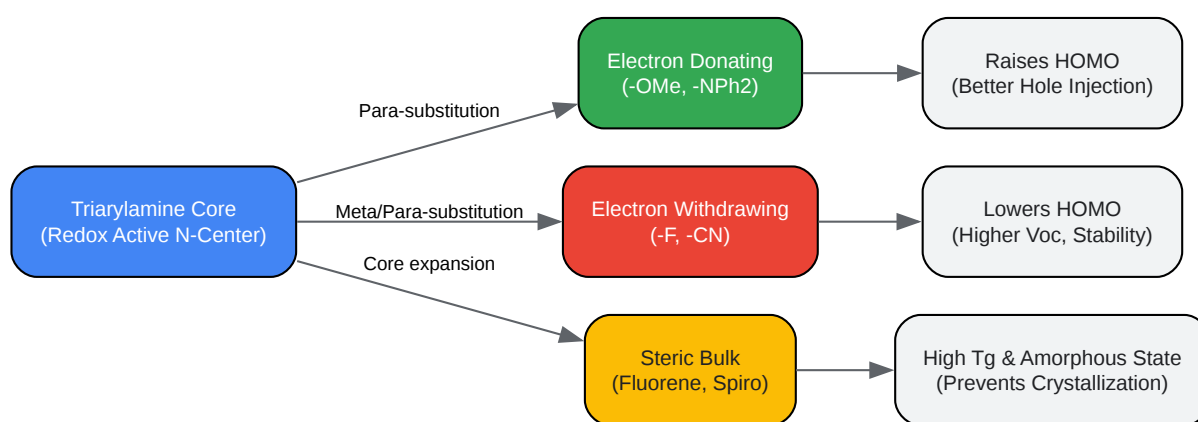

[Click to download full resolution via product page](#)

Caption: Causal map illustrating how specific chemical substitutions on the triarylamine core dictate electronic energy levels and morphological stability.

Key Application Domains

Perovskite Solar Cells (PSCs)

TAA is the standard for Hole Transport Materials (HTMs) in n-i-p perovskite architectures.^[1] The benchmark material, Spiro-OMeTAD, is a TAA derivative. However, recent research focuses on cost-effective alternatives like star-shaped TAAs and fluorinated derivatives.

- Mechanism: The HTM extracts photogenerated holes from the perovskite valence band and transports them to the metal electrode.
- Critical Protocol (Doping): Pristine TAAs often have low hole mobility (

cm^2/Vs). They require chemical doping with Li-TFSI (lithium bis(trifluoromethanesulfonyl)imide) and tBP (4-tert-butylpyridine) to generate radical cations (polarons) that increase conductivity to

cm^2/Vs .

Comparative Data: High-Performance TAA Derivatives

Material	Molecular Design Feature	PCE (%)	Hole Mobility (cm ² /Vs)	Key Advantage
Spiro-OMeTAD	Spiro-core, methoxy donors	~22-25%		Industry Benchmark
DTP-FOS	Fluorinated TAA arms	23.6%	High	Enhanced thermal stability
DImBT-4D	Imidazole-capped bithiophene	20.11%	Comparable to Spiro	Lower synthesis cost
STR0	Oxygen-bridged core	13.3%	range	High Tg, amorphous stability

Organic Light-Emitting Diodes (OLEDs)

In OLEDs, TAAs function primarily as the Hole Transport Layer (HTL) and Hole Injection Layer (HIL).

- Role: They step down the energy barrier between the anode (ITO) and the emissive layer.^[2]
- Cross-Linking: To enable solution processing of multilayer stacks (where the second solvent dissolves the first layer), TAAs are functionalized with cross-linkable groups (e.g., styryl or oxetane). Upon heating, these form an insoluble network.

Biological & Theranostic Applications

For drug development professionals, TAAs offer a scaffold for fluorescent probes and photosensitizers.

- AIE Active Probes: Unlike traditional dyes that quench in aggregate (ACQ), TAA derivatives often exhibit Aggregation-Induced Emission (AIE) due to the restriction of intramolecular rotation (RIR) in the solid state or when bound to biomolecules.

- ROS Detection: TAA probes can be designed to react specifically with Reactive Oxygen Species (ROS) or sulfur dioxide derivatives in mitochondria, changing fluorescence upon oxidation.

Experimental Protocols (Self-Validating Systems)

Synthesis: Buchwald-Hartwig Amination

The most reliable method for synthesizing TAA derivatives is Palladium-catalyzed C-N coupling.

Protocol: Synthesis of a Star-Shaped TAA (General Procedure)

- Objective: Couple a secondary amine (e.g., diphenylamine) with an aryl halide core.
- Reagents:
 - Aryl Halide (1.0 equiv)^[3]
 - Secondary Amine (1.2 equiv per halide)
 - Catalyst:
(2-5 mol%) or
 - Ligand:
or BINAP (2-4 equiv relative to Pd)
 - Base:
(Sodium tert-butoxide) (1.5 equiv per halide)
 - Solvent: Anhydrous Toluene or Xylene

Step-by-Step Workflow:

- Inert Atmosphere: Flame-dry a Schlenk flask and cycle with /Argon 3 times. Oxygen poisons the Pd catalyst.

- **Mixing:** Add Aryl Halide, Amine, Base, and Toluene. Degas the solvent by bubbling for 20 mins.
- **Catalyst Addition:** Add Pd source and Ligand quickly under positive flow.
- **Reaction:** Heat to 110°C (reflux) for 12–24 hours. Monitor via TLC (Thin Layer Chromatography).
- **Work-up:** Cool to RT. Filter through a Celite pad (removes Pd black and salts). Wash with dichloromethane.
- **Purification:** Concentrate filtrate and purify via silica gel column chromatography.

Validation Checkpoint:

- **NMR:** Verify disappearance of N-H peak (approx. 5-6 ppm) and appearance of new aromatic protons.
- **Mass Spec:** Confirm molecular ion peak

Visualization: Synthesis Workflow

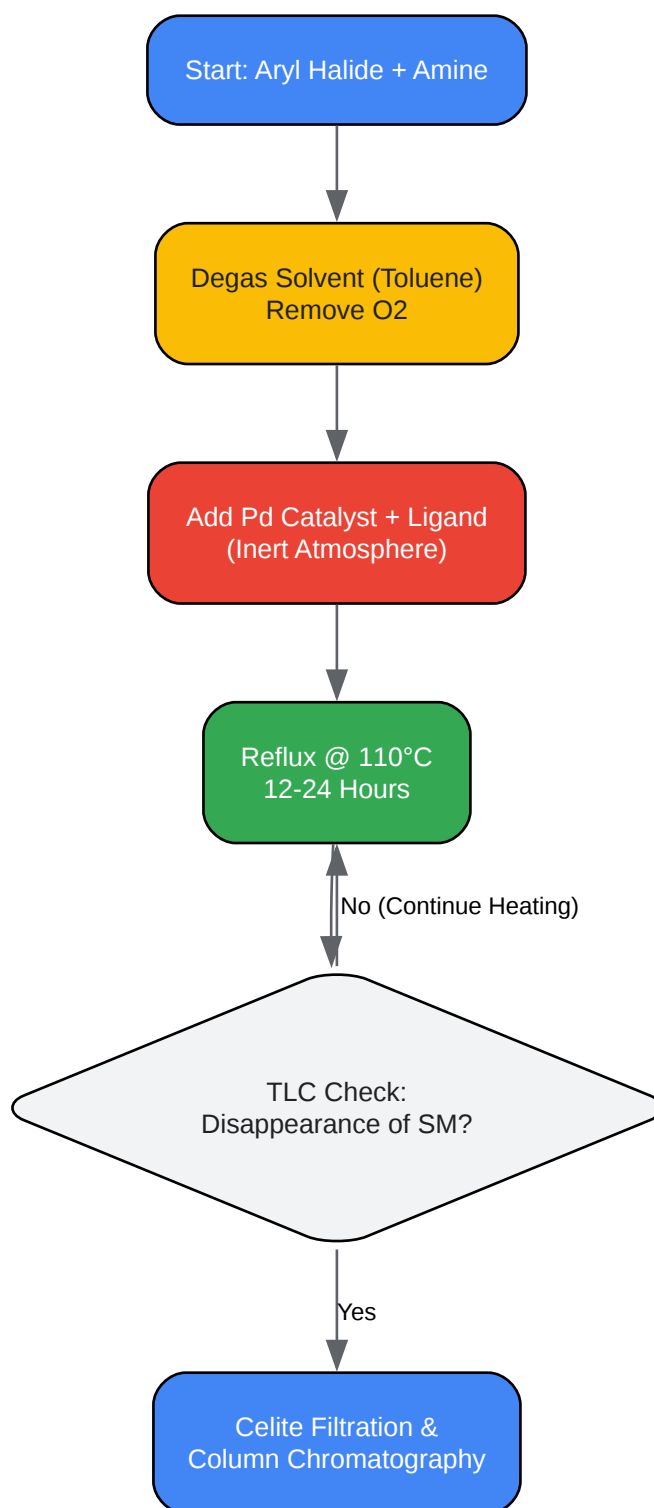

[Click to download full resolution via product page](#)

Caption: Operational workflow for the Buchwald-Hartwig amination synthesis of triarylamines.

Characterization: Hole Mobility (SCLC Method)

To validate a TAA as an HTM, you must measure its hole mobility using the Space Charge Limited Current (SCLC) method.

Protocol:

- Device Fabrication: Fabricate a "hole-only" device: ITO / PEDOT:PSS / TAA-Film / Au. (Note: The high work function of Au prevents electron injection).
- Measurement: Apply voltage () and measure current density () in the dark.
- Analysis: Fit the curve to the Mott-Gurney law:
 - Where is mobility, is film thickness, and is permittivity.
- Validation: The plot of vs. should be linear in the SCLC region.

References

- Star-shaped triarylamine-based hole-transport materials in perovskite solar cells. Sustainable Energy & Fuels. [Link](#)
- Triarylamine-Functionalized Imidazolyl-Capped Bithiophene Hole Transporting Material for Cost-Effective Perovskite Solar Cells. ACS Applied Materials & Interfaces. [Link](#)

- Heteroatom engineering of ortho-fluorinated triarylamine based hole transport materials for enhanced performance in perovskite solar cells. *Journal of Materials Chemistry A*. [Link](#)
- Rational design of one-dimensional triarylamine-based covalent organic frameworks for perovskite solar cells. *Journal of Materials Chemistry A*. [Link](#)
- Clean synthesis of triarylamines: Buchwald–Hartwig reaction in water. *Chemical Communications*. [Link](#)
- Advancements and Future Perspectives of Triphenylamine-Based Fluorescent Probes in Biomedical Applications. *Biomaterials*. [Link](#)
- Hole Transport in Triphenylamine Based OLED Devices: From Theoretical Modeling to Properties Prediction. *The Journal of Physical Chemistry A*. [Link](#)

Need Custom Synthesis?

BenchChem offers custom synthesis for rare earth carbides and specific isotopic labeling.

Email: info@benchchem.com or [Request Quote Online](#).

Sources

- [1. nanoGe - HOPE-PV - Design and Investigation of Triarylamine Derivatives as Hole Transport Materials for Perovskite Solar Cells \[nanoge.org\]](#)
- [2. pubs.acs.org \[pubs.acs.org\]](#)
- [3. organic-synthesis.com \[organic-synthesis.com\]](#)
- To cite this document: BenchChem. [Potential Applications of Substituted Triarylamines in Materials Science: A Technical Guide]. BenchChem, [2026]. [Online PDF]. Available at: [<https://www.benchchem.com/product/b14179613/docs#potential-applications-of-substituted-triarylamines-in-materials-science-a-technical-guide>]

Disclaimer & Data Validity:

The information provided in this document is for Research Use Only (RUO) and is strictly not intended for diagnostic or therapeutic procedures. While BenchChem strives to provide

accurate protocols, we make no warranties, express or implied, regarding the fitness of this product for every specific experimental setup.

Technical Support: The protocols provided are for reference purposes. Unsure if this reagent suits your experiment?

Need Industrial/Bulk Grade? [Request Custom Synthesis Quote](#)

BenchChem

Our mission is to be the trusted global source of essential and advanced chemicals, empowering scientists and researchers to drive progress in science and industry.

Contact

Address: 3281 E Guasti Rd

Ontario, CA 91761, United States

Phone: (601) 213-4426

Email: info@benchchem.com

[Contact our Ph.D. Support Team for a compatibility check](#)