

# Technical Support Center: IGF-1R Inhibitor-5

**Author:** BenchChem Technical Support Team. **Date:** April 2026

## Compound of Interest

Compound Name: IGF-1R inhibitor-5

CAS No.: 1218777-14-0

Cat. No.: B14170300

[Get Quote](#)

This technical support center provides troubleshooting guidance and frequently asked questions (FAQs) for researchers using **IGF-1R inhibitor-5** in cell line-based experiments. The information is compiled to address common challenges and provide standardized protocols for assessing the inhibitor's effects.

## Frequently Asked Questions (FAQs)

Q1: What is the general mechanism of action for **IGF-1R inhibitor-5**?

A1: **IGF-1R inhibitor-5** is a potent inhibitor of the Insulin-like Growth Factor-1 Receptor (IGF-1R) with an IC50 of 6  $\mu\text{M}$ .<sup>[1][2]</sup> By targeting IGF-1R, the inhibitor blocks downstream signaling pathways crucial for cell growth, proliferation, and survival, such as the PI3K/AKT and MAPK pathways.<sup>[3]</sup> This inhibition can lead to reduced tumor growth and an increase in apoptosis (programmed cell death) in cancer cells.<sup>[3]</sup>

Q2: I am not observing the expected decrease in cell viability after treating my cells with **IGF-1R inhibitor-5**. What could be the reason?

A2: Several factors could contribute to a lack of response. Firstly, the cell line you are using may have low expression levels of IGF-1R, making it inherently resistant to an IGF-1R-specific

inhibitor. Secondly, the cells might have developed resistance through the activation of alternative survival pathways. For instance, Src activation has been reported to confer resistance to anti-IGF-1R therapeutics. It is also possible that the inhibitor concentration is too low or the treatment duration is too short to induce a significant effect.

Q3: How can I confirm that **IGF-1R inhibitor-5** is hitting its target in my cell line?

A3: To confirm target engagement, you can perform a Western blot analysis to assess the phosphorylation status of IGF-1R and its downstream effectors, such as Akt and ERK. A successful inhibition should result in a decrease in the phosphorylated forms of these proteins upon treatment with **IGF-1R inhibitor-5**.

Q4: What are the potential off-target effects of **IGF-1R inhibitor-5**?

A4: Due to the high homology between IGF-1R and the Insulin Receptor (IR), small molecule inhibitors of IGF-1R may also inhibit the IR to some degree.[4] This can lead to metabolic effects and should be considered when interpreting your results. It is advisable to assess the effect of the inhibitor on IR signaling, especially at higher concentrations.

Q5: What are the recommended positive and negative controls for my experiments?

A5: For a positive control, you could use a well-characterized IGF-1R inhibitor like Linsitinib (OSI-906) or a cell line known to be sensitive to IGF-1R inhibition.[5][6] As a negative control, you should use a vehicle control (e.g., DMSO) at the same concentration used to dissolve the inhibitor. Additionally, using a cell line with low or no IGF-1R expression can serve as a biological negative control.

## Troubleshooting Guides

### Problem: High Variability in Cell Viability Assays

Possible Cause	Recommended Solution
Inconsistent cell seeding density.	Ensure a homogenous cell suspension and accurate cell counting before seeding. Use a multichannel pipette for seeding to minimize variability between wells.
Edge effects in multi-well plates.	Avoid using the outer wells of the plate, as they are more prone to evaporation. Fill the outer wells with sterile PBS or media.
Inhibitor precipitation.	Visually inspect the media for any signs of precipitation after adding the inhibitor. If precipitation occurs, try dissolving the compound in a different solvent or using a lower concentration.
Cell clumping.	Ensure single-cell suspension before seeding by gentle pipetting or passing through a cell strainer.

## Problem: No significant increase in apoptosis after treatment.

Possible Cause	Recommended Solution
Sub-optimal inhibitor concentration or treatment time.	Perform a dose-response and time-course experiment to determine the optimal conditions for inducing apoptosis in your specific cell line.
Apoptosis assay is not sensitive enough.	Try a more sensitive method. For example, if you are using a DNA fragmentation assay with low signal, consider switching to a TUNEL assay or Annexin V staining followed by flow cytometry.
Cells are undergoing a different form of cell death.	Investigate other cell death mechanisms, such as necrosis or autophagy. Use specific markers and assays for these pathways.
Cell line is resistant to apoptosis.	This could be due to high levels of anti-apoptotic proteins (e.g., Bcl-2). Consider combining IGF-1R inhibitor-5 with other agents that can sensitize cells to apoptosis.

## Quantitative Data Summary

The following table summarizes hypothetical data for **IGF-1R inhibitor-5** in different cancer cell lines. This data is for illustrative purposes and should be experimentally determined for your specific cell lines of interest.

Cell Line	Cancer Type	IGF-1R Expression	IC50 ( $\mu$ M) of IGF-1R inhibitor-5	% Apoptosis (at 2x IC50)
MCF-7	Breast Cancer	High	5.8	45%
A549	Lung Cancer	Moderate	12.5	25%
HCT116	Colon Cancer	High	7.2	38%
U87 MG	Glioblastoma	Low	> 50	< 5%

## Experimental Protocols

### Cell Viability Assay (MTT Assay)

- Seed cells in a 96-well plate at a density of 5,000-10,000 cells/well and allow them to attach overnight.
- Treat the cells with various concentrations of **IGF-1R inhibitor-5** (and vehicle control) for 24, 48, or 72 hours.
- Add 20  $\mu$ L of MTT solution (5 mg/mL in PBS) to each well and incubate for 4 hours at 37°C.
- Remove the media and add 150  $\mu$ L of DMSO to each well to dissolve the formazan crystals.
- Measure the absorbance at 570 nm using a microplate reader.
- Calculate cell viability as a percentage of the vehicle-treated control.

### Apoptosis Assay (TUNEL Assay)

- Seed cells on coverslips in a 24-well plate and treat with **IGF-1R inhibitor-5** for the desired time.
- Fix the cells with 4% paraformaldehyde for 25 minutes at room temperature.
- Permeabilize the cells with 0.2% Triton X-100 in PBS for 5 minutes.
- Perform the TUNEL staining according to the manufacturer's protocol.
- Counterstain the nuclei with DAPI.
- Mount the coverslips on microscope slides and visualize using a fluorescence microscope.
- Quantify the percentage of TUNEL-positive (apoptotic) cells.

### Western Blot Analysis

- Treat cells with **IGF-1R inhibitor-5** for the indicated times.
- Lyse the cells in RIPA buffer supplemented with protease and phosphatase inhibitors.

- Determine the protein concentration of the lysates using a BCA assay.
- Separate 20-30 µg of protein per lane on an SDS-PAGE gel.
- Transfer the proteins to a PVDF membrane.
- Block the membrane with 5% non-fat milk or BSA in TBST for 1 hour.
- Incubate the membrane with primary antibodies against p-IGF-1R, IGF-1R, p-Akt, Akt, p-ERK, ERK, and a loading control (e.g., GAPDH or β-actin) overnight at 4°C.
- Wash the membrane and incubate with the appropriate HRP-conjugated secondary antibody for 1 hour at room temperature.
- Detect the signal using an enhanced chemiluminescence (ECL) substrate and an imaging system.

## Visualizations

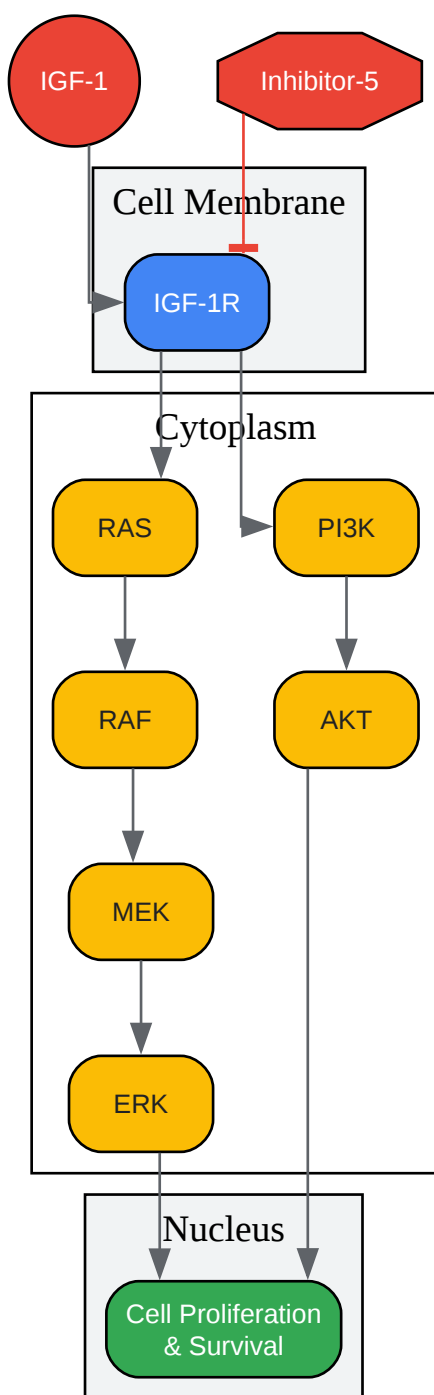

[Click to download full resolution via product page](#)

Caption: IGF-1R signaling pathway and the inhibitory action of **IGF-1R inhibitor-5**.

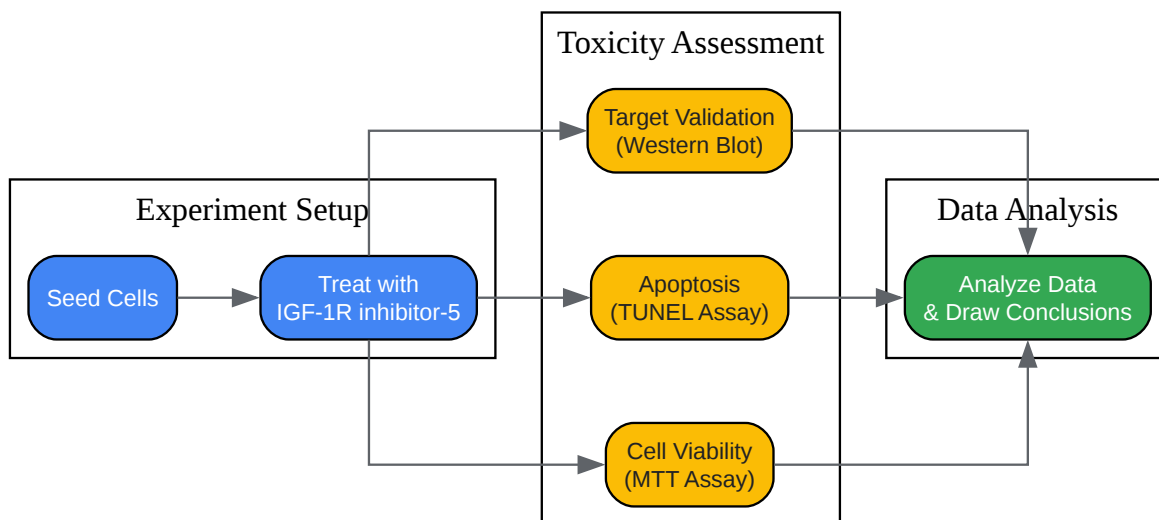

[Click to download full resolution via product page](#)

Caption: General experimental workflow for assessing the toxicity of **IGF-1R inhibitor-5**.

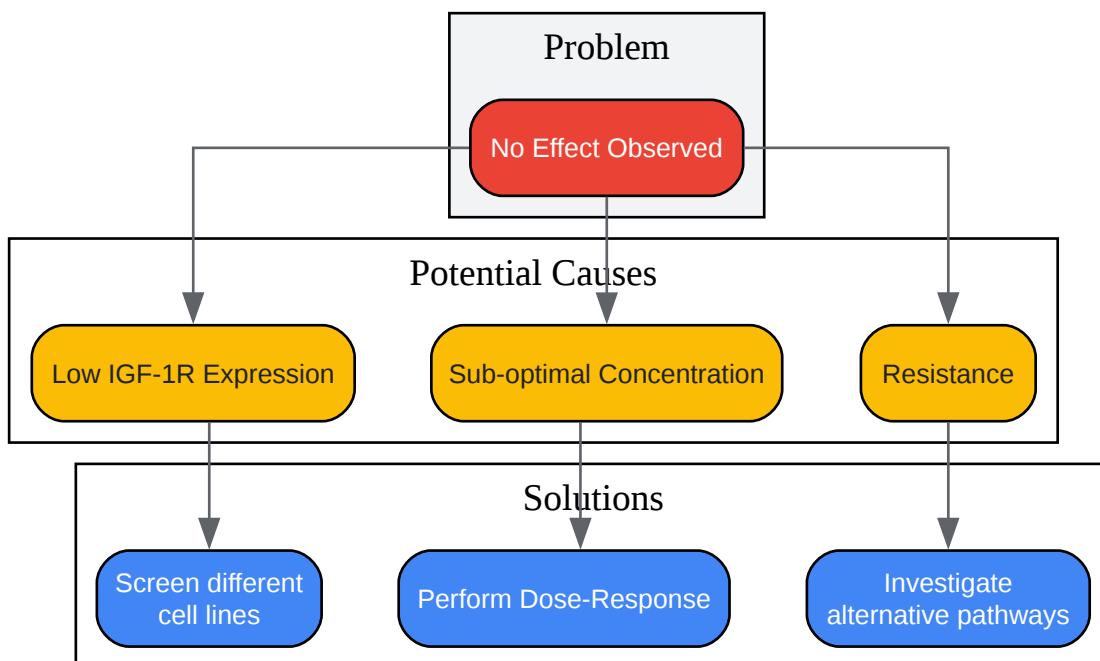

[Click to download full resolution via product page](#)

Caption: A logical flow for troubleshooting experiments where no effect of the inhibitor is observed.

### Need Custom Synthesis?

BenchChem offers custom synthesis for rare earth carbides and specific isotopic labeling.

Email: [info@benchchem.com](mailto:info@benchchem.com) or [Request Quote Online](#).

## References

- [1. medchemexpress.com \[medchemexpress.com\]](https://www.medchemexpress.com)
- [2. medchemexpress.com \[medchemexpress.com\]](https://www.medchemexpress.com)
- [3. What are IGF-1R antagonists and how do they work? \[synapse.patsnap.com\]](https://synapse.patsnap.com)
- [4. aacrjournals.org \[aacrjournals.org\]](https://aacrjournals.org)
- [5. IGF-1R Inhibition Suppresses Cell Proliferation and Increases Radiosensitivity in Nasopharyngeal Carcinoma Cells - PMC \[pmc.ncbi.nlm.nih.gov\]](https://pubmed.ncbi.nlm.nih.gov)
- [6. selleckchem.com \[selleckchem.com\]](https://www.selleckchem.com)
- To cite this document: BenchChem. [Technical Support Center: IGF-1R Inhibitor-5]. BenchChem, [2026]. [Online PDF]. Available at: [\[https://www.benchchem.com/product/b14170300/docs#technical-support-center-igf-1r-inhibitor-5\]](https://www.benchchem.com/product/b14170300/docs#technical-support-center-igf-1r-inhibitor-5)

---

### Disclaimer & Data Validity:

The information provided in this document is for Research Use Only (RUO) and is strictly not intended for diagnostic or therapeutic procedures. While BenchChem strives to provide accurate protocols, we make no warranties, express or implied, regarding the fitness of this product for every specific experimental setup.

**Technical Support:** The protocols provided are for reference purposes. Unsure if this reagent suits your experiment?

**Need Industrial/Bulk Grade?** [Request Custom Synthesis Quote](#)

# BenchChem

Our mission is to be the trusted global source of essential and advanced chemicals, empowering scientists and researchers to drive progress in science and industry.

## Contact

Address: 3281 E Guasti Rd

Ontario, CA 91761, United States

Phone: (601) 213-4426

Email: [info@benchchem.com](mailto:info@benchchem.com)

[Contact our Ph.D. Support Team for a compatibility check](#)