

# Technical Support Center: Trisulfo-Cy3-Alkyne Labeling Experiments

**Author:** BenchChem Technical Support Team. **Date:** April 2026

## Compound of Interest

Compound Name: *Trisulfo-Cy3-Alkyne*

Cat. No.: *B1417858*

[Get Quote](#)

This technical support center provides troubleshooting guides and frequently asked questions (FAQs) for researchers, scientists, and drug development professionals using **Trisulfo-Cy3-Alkyne** for fluorescent labeling via copper-catalyzed azide-alkyne cycloaddition (CuAAC), commonly known as "click chemistry."

## Frequently Asked Questions (FAQs)

Q1: What is **Trisulfo-Cy3-Alkyne**?

A1: **Trisulfo-Cy3-Alkyne** is a water-soluble fluorescent dye containing a terminal alkyne group. [1][2][3] This alkyne functional group allows it to be covalently attached to molecules containing an azide group through a click chemistry reaction.[1] The Trisulfo-Cy3 component is a bright and photostable cyanine dye that fluoresces in the red region of the visible spectrum.[1][2] Its water solubility makes it suitable for labeling biomolecules in aqueous buffers.[1]

Q2: What are the excitation and emission wavelengths for Trisulfo-Cy3?

A2: The approximate excitation maximum for Trisulfo-Cy3 is 550 nm, and its emission maximum is around 570 nm.[2][4]

Q3: What is the principle of **Trisulfo-Cy3-Alkyne** labeling?

A3: The labeling reaction is based on the copper(I)-catalyzed azide-alkyne cycloaddition (CuAAC). In this reaction, the alkyne group on the Trisulfo-Cy3 molecule specifically and efficiently reacts with an azide group on a target molecule (e.g., a protein, nucleic acid, or small molecule) to form a stable triazole linkage.[3][4] This reaction is highly specific and bioorthogonal, meaning it does not interfere with native biological functional groups.[4][5]

Q4: What are the key components of a **Trisulfo-Cy3-Alkyne** labeling reaction?

A4: A typical CuAAC reaction for labeling includes:

- Azide-modified biomolecule: The target molecule to be labeled.
- **Trisulfo-Cy3-Alkyne**: The fluorescent probe.
- Copper(I) catalyst: Often generated in situ from a copper(II) source like copper(II) sulfate (CuSO<sub>4</sub>).[6]
- Reducing agent: Typically sodium ascorbate, to reduce Cu(II) to the active Cu(I) state.[7][8]
- Copper-chelating ligand: Such as THPTA (Tris(3-hydroxypropyltriazolylmethyl)amine) or BTAA, to stabilize the Cu(I) catalyst and improve reaction efficiency.[7][9]

Q5: How should I store **Trisulfo-Cy3-Alkyne**?

A5: **Trisulfo-Cy3-Alkyne** should be stored at -20°C in the dark and protected from moisture.[2][10] Stock solutions, typically prepared in an organic solvent like DMSO or DMF, should also be stored at -20°C or -80°C and protected from light.[11][12] It is advisable to aliquot the stock solution to avoid repeated freeze-thaw cycles.[11]

## Troubleshooting Guides

### Problem 1: No or Low Fluorescent Signal

Q: I am not seeing any fluorescent signal, or the signal is very weak. What could be the problem?

A: This is a common issue that can arise from several factors. Below is a systematic guide to troubleshoot the problem.

- Inefficient Click Reaction: The core of the labeling process is the click reaction. If this reaction is inefficient, you will have a low degree of labeling.
  - Inactive Catalyst: The active catalyst is Copper(I). Oxygen in the solution can oxidize Cu(I) to the inactive Cu(II) state.[13]
    - Solution: Always use freshly prepared sodium ascorbate solution.[13] Degassing your reaction buffer to remove dissolved oxygen can also help.[13] Ensure you are using a copper-stabilizing ligand in sufficient excess (e.g., 5-10 fold) over the copper sulfate.[9]
  - Low Reactant Concentrations: Click reactions are dependent on the concentration of the reactants.[13]
    - Solution: Increase the concentration of the **Trisulfo-Cy3-Alkyne** probe. A 2- to 10-fold molar excess over the azide-labeled biomolecule is a good starting point.[13] You can also optimize the concentrations of the copper, ligand, and reducing agent.[13]
  - Incorrect Reagent Ratios: The ratio of ligand to copper is crucial for protecting the catalyst.
    - Solution: A 5:1 ligand to copper ratio is often recommended to protect the Cu(I) catalyst. [13]
- Issues with the Labeled Molecule:
  - Low Incorporation of Azide: If the azide group was not efficiently incorporated into your target biomolecule, there will be nothing for the **Trisulfo-Cy3-Alkyne** to react with.
    - Solution: Verify the successful incorporation of the azide into your biomolecule using an independent method if possible.
  - Precipitation of the Labeled Molecule: Modifying a biomolecule with a dye can sometimes lead to precipitation, especially if the degree of labeling is too high.[14]

- Solution: Try lowering the molar ratio of the dye to your molecule during the labeling reaction to reduce the degree of labeling.[\[14\]](#)
- Fluorescence Quenching:
  - Dye-Dye Quenching: If too many dye molecules are attached to a single biomolecule, they can quench each other's fluorescence, leading to a lower-than-expected signal.[\[14\]](#)[\[15\]](#)
  - Solution: Reduce the molar excess of **Trisulfo-Cy3-Alkyne** used in the labeling reaction to achieve a lower degree of labeling (DOL).
  - Environmental Quenching: The local environment around the dye can affect its fluorescence.[\[14\]](#)
  - Solution: This can be difficult to control, but sometimes changing the buffer conditions (pH, ionic strength) can help.
- Imaging and Detection Issues:
  - Incorrect Filter Sets: Ensure that the excitation and emission filters on your fluorescence microscope or imager are appropriate for Cy3.[\[16\]](#)
  - Photobleaching: Cy3, like all fluorescent dyes, can be susceptible to photobleaching (fading) upon prolonged exposure to excitation light.[\[17\]](#)
  - Solution: Use an anti-fade mounting medium if possible and minimize the exposure time to the excitation light.[\[16\]](#)

## Problem 2: High Background Signal

Q: My images have a high, non-specific background fluorescence. How can I reduce it?

A: High background can obscure your specific signal and make data interpretation difficult. Here are the common causes and solutions:

- Excess Unbound Dye: The most common cause of high background is the presence of unreacted **Trisulfo-Cy3-Alkyne** that was not removed after the labeling reaction.[\[9\]](#)[\[18\]](#)

- Solution: Thorough purification of the labeled conjugate is critical. Methods like size-exclusion chromatography (e.g., Sephadex G25), dialysis, or precipitation (e.g., with acetone) can be used to remove free dye.[5][9][19] Increasing the number and duration of wash steps after labeling can also help.[20][21]
- Non-Specific Binding of the Dye: The fluorescent probe may non-specifically adhere to surfaces or other molecules in your sample.[9][22]
  - Solution:
    - Decrease the concentration of the **Trisulfo-Cy3-Alkyne** probe used in the reaction.[9]
    - Include a blocking agent like Bovine Serum Albumin (BSA) in your buffers, especially for cell-based imaging.[9]
    - Increase the number and duration of washing steps after the labeling reaction.[20]
- Reagent Impurities: Impurities in the alkyne or azide reagents can contribute to background signals.[9]
  - Solution: Use high-quality, purified reagents.
- Autofluorescence: Biological samples themselves can have intrinsic fluorescence (autofluorescence), which can contribute to background.[16][20]
  - Solution:
    - Image an unstained control sample to determine the level of autofluorescence.[16][20]
    - If autofluorescence is high, you may need to use spectral unmixing techniques or choose a dye in a different spectral range if possible.
- Copper-Mediated Fluorescence: Copper ions themselves can sometimes contribute to background fluorescence.[9]
  - Solution: Ensure you are using a copper-chelating ligand (like THPTA or BTTAA) in sufficient excess.[9] A final wash with a chelator like EDTA can also help remove residual copper.[9]

## Data Presentation

Table 1: Recommended Reagent Concentrations for a Typical CuAAC Labeling Reaction

Reagent	Typical Concentration Range	Key Considerations
Azide-modified Biomolecule	Varies depending on the experiment	The starting point for concentration calculations.
Trisulfo-Cy3-Alkyne	2-10 molar excess over the azide	Higher excess can drive the reaction but may increase background.
Copper(II) Sulfate (CuSO <sub>4</sub> )	50 - 100 μM[7]	The source of the copper catalyst.
Copper-chelating Ligand (e.g., THPTA)	5-10 fold molar excess over CuSO <sub>4</sub> [7][9]	Protects the Cu(I) catalyst and improves reaction kinetics.
Sodium Ascorbate	0.5 - 1.0 mM (5-10 fold molar excess over CuSO <sub>4</sub> )	Should be prepared fresh to act as an efficient reducing agent.[13]

## Experimental Protocols

### Protocol: General Procedure for Labeling an Azide-Modified Protein with Trisulfo-Cy3-Alkyne

This protocol provides a general starting point. Optimal conditions may vary depending on the specific protein and experimental setup.

Materials:

- Azide-modified protein in a suitable buffer (e.g., PBS, pH 7.4). Note: Avoid buffers containing primary amines like Tris, as they can interfere with some labeling chemistries.[13]
- **Trisulfo-Cy3-Alkyne**

- DMSO or DMF (anhydrous)
- Copper(II) Sulfate ( $\text{CuSO}_4$ ) stock solution (e.g., 20 mM in water)
- THPTA stock solution (e.g., 50 mM in water)
- Sodium Ascorbate stock solution (e.g., 100 mM in water, prepare fresh)
- Purification column (e.g., Sephadex G-25)

Procedure:

- Prepare Reagent Solutions:
  - Dissolve **Trisulfo-Cy3-Alkyne** in DMSO or DMF to prepare a stock solution (e.g., 10 mM).
  - Prepare a fresh solution of sodium ascorbate in water.
- Prepare the Reaction Mixture:
  - In a microcentrifuge tube, add your azide-modified protein to the desired final concentration in the reaction buffer.
  - Add the **Trisulfo-Cy3-Alkyne** stock solution to achieve the desired molar excess (e.g., 5-fold molar excess over the protein).
  - In a separate tube, premix the  $\text{CuSO}_4$  and THPTA solutions. For example, mix 2.5  $\mu\text{l}$  of 20 mM  $\text{CuSO}_4$  and 5.0  $\mu\text{l}$  of 50 mM THPTA.[\[23\]](#)
  - Add the premixed  $\text{CuSO}_4$ /THPTA solution to the protein-dye mixture to a final copper concentration of 50-100  $\mu\text{M}$ .[\[7\]](#)[\[23\]](#)
- Initiate the Reaction:
  - Add the freshly prepared sodium ascorbate solution to the reaction mixture to a final concentration of approximately 1 mM.
  - Gently mix the reaction and protect it from light.

- Incubation:
  - Incubate the reaction at room temperature for 1-2 hours. The optimal time may need to be determined empirically.
- Purification:
  - Purify the labeled protein from excess dye and reaction components using a size-exclusion chromatography column (e.g., a pre-packed Sephadex G-25 column).
  - Collect the fractions containing the labeled protein (the colored band that elutes first).
- Characterization (Optional but Recommended):
  - Determine the degree of labeling (DOL) by measuring the absorbance of the protein (e.g., at 280 nm) and the Cy3 dye (at ~550 nm).

## Mandatory Visualization

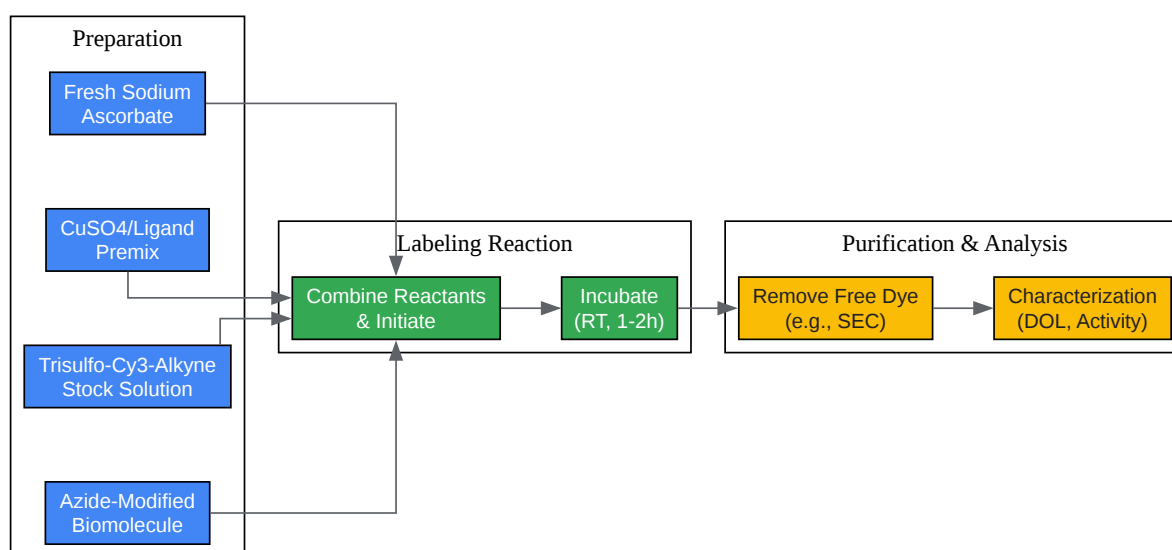

[Click to download full resolution via product page](#)

Caption: Experimental workflow for **Trisulfo-Cy3-Alkyne** labeling.

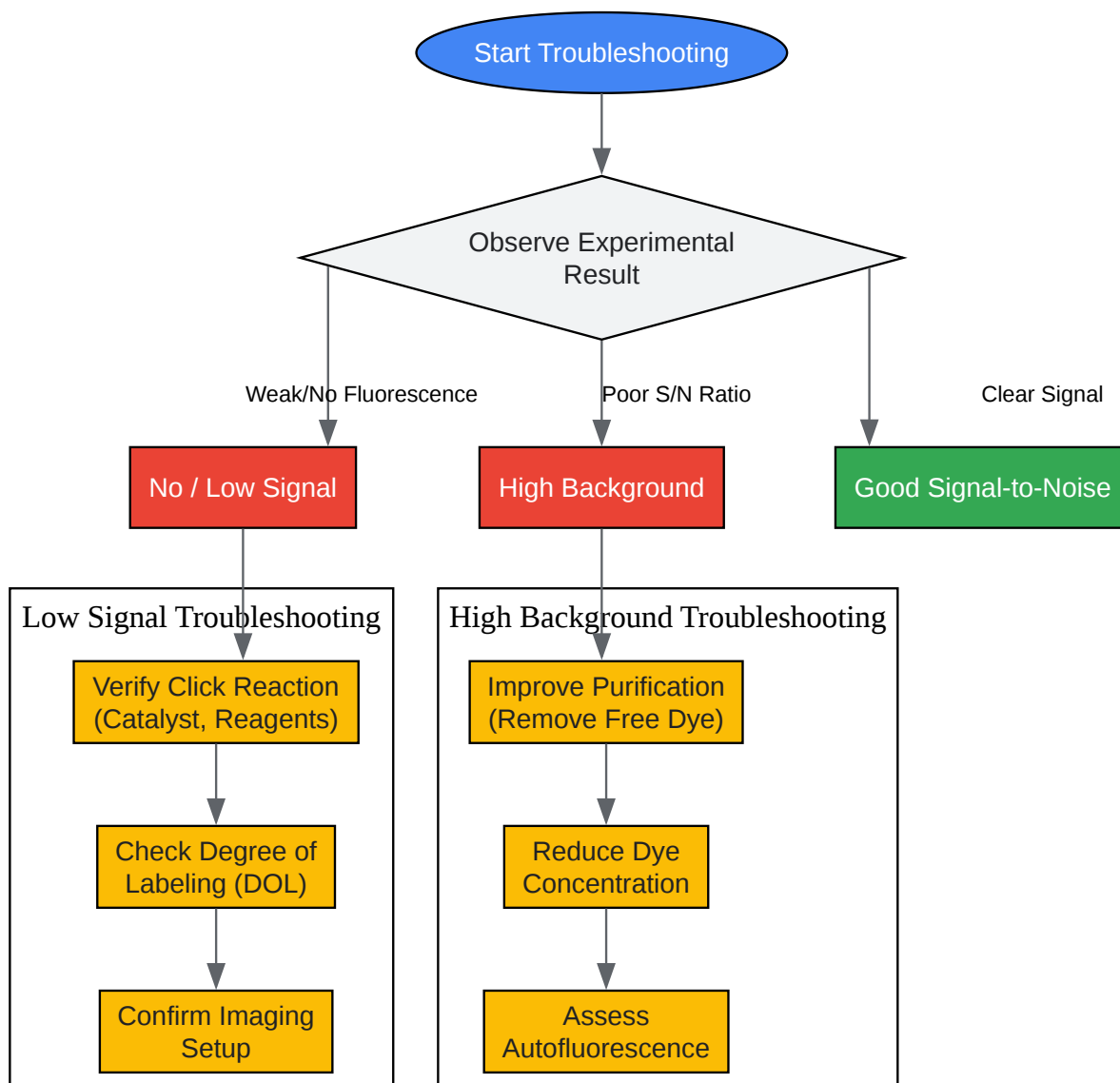

[Click to download full resolution via product page](#)

Caption: Troubleshooting decision tree for labeling experiments.

### Need Custom Synthesis?

BenchChem offers custom synthesis for rare earth carbides and specific isotopic labeling.

Email: [info@benchchem.com](mailto:info@benchchem.com) or [Request Quote Online](#).

## References

- [1. medchemexpress.com](https://www.medchemexpress.com) [[medchemexpress.com](https://www.medchemexpress.com)]
- [2. Trisulfo-Cy3-Alkyne | BroadPharm](https://www.broadpharm.com) [[broadpharm.com](https://www.broadpharm.com)]
- [3. tenovapharma.com](https://www.tenovapharma.com) [[tenovapharma.com](https://www.tenovapharma.com)]
- [4. interchim.fr](https://www.interchim.fr) [[interchim.fr](https://www.interchim.fr)]
- [5. fnkprddata.blob.core.windows.net](https://fnkprddata.blob.core.windows.net) [[fnkprddata.blob.core.windows.net](https://fnkprddata.blob.core.windows.net)]
- [6. benchchem.com](https://www.benchchem.com) [[benchchem.com](https://www.benchchem.com)]
- [7. Analysis and Optimization of Copper-Catalyzed Azide–Alkyne Cycloaddition for Bioconjugation - PMC](https://pubmed.ncbi.nlm.nih.gov/28111111/) [[pmc.ncbi.nlm.nih.gov](https://pubmed.ncbi.nlm.nih.gov/28111111/)]
- [8. jenabioscience.com](https://www.jenabioscience.com) [[jenabioscience.com](https://www.jenabioscience.com)]
- [9. benchchem.com](https://www.benchchem.com) [[benchchem.com](https://www.benchchem.com)]
- [10. lumiprobe.com](https://www.lumiprobe.com) [[lumiprobe.com](https://www.lumiprobe.com)]
- [11. medchemexpress.com](https://www.medchemexpress.com) [[medchemexpress.com](https://www.medchemexpress.com)]
- [12. apexbt.com](https://www.apexbt.com) [[apexbt.com](https://www.apexbt.com)]
- [13. benchchem.com](https://www.benchchem.com) [[benchchem.com](https://www.benchchem.com)]
- [14. Labeling Chemistry Support—Troubleshooting | Thermo Fisher Scientific - HK](https://www.thermofisher.com) [[thermofisher.com](https://www.thermofisher.com)]
- [15. pubs.acs.org](https://pubs.acs.org) [[pubs.acs.org](https://pubs.acs.org)]
- [16. biotium.com](https://www.biotium.com) [[biotium.com](https://www.biotium.com)]
- [17. blog.addgene.org](https://blog.addgene.org) [[blog.addgene.org](https://blog.addgene.org)]
- [18. Fluorescent labeling and modification of proteins - PMC](https://pubmed.ncbi.nlm.nih.gov/28111111/) [[pmc.ncbi.nlm.nih.gov](https://pubmed.ncbi.nlm.nih.gov/28111111/)]
- [19. lumiprobe.com](https://www.lumiprobe.com) [[lumiprobe.com](https://www.lumiprobe.com)]
- [20. benchchem.com](https://www.benchchem.com) [[benchchem.com](https://www.benchchem.com)]
- [21. Background in Fluorescence Imaging | Thermo Fisher Scientific - US](https://www.thermofisher.com) [[thermofisher.com](https://www.thermofisher.com)]

- [22. Troubleshooting in Fluorescent Staining - Creative Bioarray | Creative Bioarray \[creative-bioarray.com\]](#)
- [23. scispace.com \[scispace.com\]](#)
- To cite this document: BenchChem. [Technical Support Center: Trisulfo-Cy3-Alkyne Labeling Experiments]. BenchChem, [2026]. [Online PDF]. Available at: [<https://www.benchchem.com/product/b1417858/docs#technical-support-center-trisulfo-cy3-alkyne-labeling-experiments>]

---

### Disclaimer & Data Validity:

The information provided in this document is for Research Use Only (RUO) and is strictly not intended for diagnostic or therapeutic procedures. While BenchChem strives to provide accurate protocols, we make no warranties, express or implied, regarding the fitness of this product for every specific experimental setup.

**Technical Support:** The protocols provided are for reference purposes. Unsure if this reagent suits your experiment?

**Need Industrial/Bulk Grade?** [Request Custom Synthesis Quote](#)

## BenchChem

Our mission is to be the trusted global source of essential and advanced chemicals, empowering scientists and researchers to drive progress in science and industry.

### Contact

Address: 3281 E Guasti Rd  
Ontario, CA 91761, United States  
Phone: (601) 213-4426  
Email: [info@benchchem.com](mailto:info@benchchem.com)

[Contact our Ph.D. Support Team for a compatibility check](#)

