

Scalable Synthesis of Oxadiazolyl Pyridin-2-ols: Process Development & Safety Controls

Author: BenchChem Technical Support Team. **Date:** April 2026

Compound of Interest

Compound Name: 3-(3-Ethyl-1,2,4-oxadiazol-5-yl)pyridin-2-ol
CAS No.: 1239753-05-9
Cat. No.: B1417832

[Get Quote](#)

Executive Summary

The oxadiazolyl pyridin-2-ol scaffold (often existing as its 2-pyridone tautomer) is a privileged structure in medicinal chemistry, appearing in GPR119 agonists, antimicrobial agents, and enzyme inhibitors. While bench-scale synthesis is well-documented, scaling this chemistry to kilogram quantities presents distinct challenges:

- **Tautomeric Control:** The free pyridin-2-ol hydroxyl group interferes with electrophilic cyclization reagents (e.g., POCl₃), necessitating an O-protection strategy.
- **Thermal Hazards:** Formation of the oxadiazole ring involves exothermic dehydration steps and potentially unstable intermediates (hydrazides/amidoximes).
- **Reagent Safety:** Traditional dehydrating agents like phosphorous oxychloride (POCl₃) pose significant corrosion and quench hazards on scale.

This guide details a Process-Optimized Route utilizing a 2-methoxypyridine intermediate to mask the hydroxyl group, followed by a late-stage demethylation. We focus on two primary

isomers: 1,2,4-oxadiazoles (via amidoximes) and 1,3,4-oxadiazoles (via hydrazides), utilizing T3P® (Propylphosphonic anhydride) as a greener, safer alternative to POCl₃.

Strategic Analysis: The "Masked" Pyridone Approach

Direct synthesis on the free pyridin-2-ol often leads to N-alkylation or O-phosphorylation side products. The most robust scale-up strategy employs 2-methoxypyridine as a stable precursor.

Retrosynthetic Workflow

- Step 1: Functionalize 2-methoxy-nicotinonitrile (for 1,2,4-isomer) or 2-methoxy-nicotinic acid (for 1,3,4-isomer).
- Step 2: Construct the oxadiazole ring using controlled cyclodehydration.
- Step 3: Demethylate the methoxy group to reveal the pyridin-2-ol/pyridone target.

Visualizing the Pathway

The following diagram outlines the divergent pathways for accessing both isomers from a common methoxy-pyridine core.

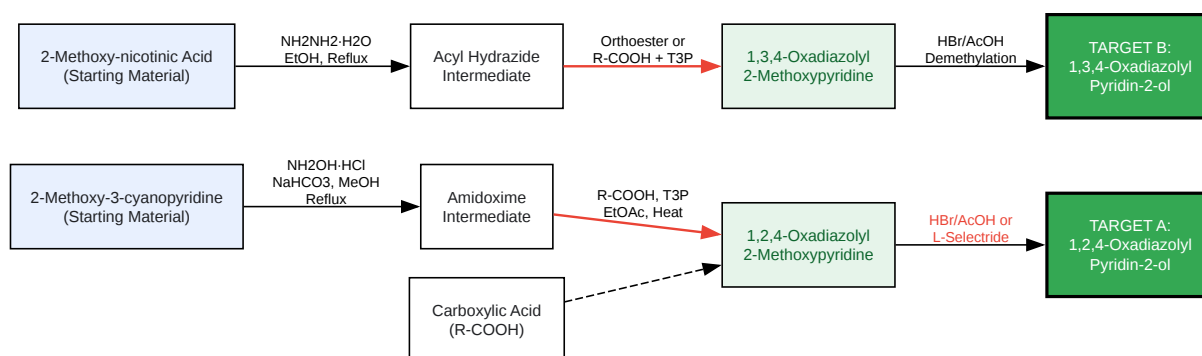

Figure 1: Divergent Synthesis of Oxadiazolyl Pyridin-2-ols via Methoxy-Protection Strategy

[Click to download full resolution via product page](#)

[1]

Protocol A: 1,2,4-Oxadiazole Synthesis (GPR119 Agonist Route)

This protocol describes the synthesis of 3-(5-substituted-1,2,4-oxadiazol-3-yl)pyridin-2-ol.

Step 1: Amidoxime Formation

Scale: 100 g Input | Hazard: Hydroxylamine (Thermal instability)

- Setup: Charge a 2L jacketed reactor with 2-methoxy-3-cyanopyridine (100 g, 0.74 mol) and Methanol (800 mL, 8 vol).
- Reagent Addition: Add Hydroxylamine hydrochloride (57 g, 0.82 mol, 1.1 eq) followed by slow addition of Sodium Bicarbonate (69 g, 0.82 mol) or Triethylamine.
 - Note: Evolution of CO₂ gas. Ensure venting is open.
- Reaction: Heat to reflux (65°C) for 6–8 hours. Monitor by HPLC (Target: <2% Nitrile).
- Workup: Cool to 20°C. Concentrate to remove MeOH. Resuspend in water (500 mL) and filter the precipitated amidoxime. Dry at 45°C under vacuum.

Step 2: T3P-Mediated Cyclization (Critical Scale-Up Step)

Rationale: T3P (Propylphosphonic anhydride) is preferred over POCl₃/CDI for scale-up due to its low toxicity, water-soluble byproducts, and milder exotherm profile [2, 3].

- Setup: In a 5L reactor, charge Amidoxime intermediate (from Step 1, ~110 g) and the coupling Carboxylic Acid (1.05 eq).
- Solvent: Add Ethyl Acetate (EtOAc) or 2-MeTHF (10 vol).

- Green Tip: 2-MeTHF offers higher process temperatures and easier phase separation than EtOAc.
- Base: Add Triethylamine (TEA) (3.0 eq). Cool mixture to 0–5°C.
- T3P Addition: Charge T3P (50% w/w in EtOAc) (1.5 eq) slowly via addition funnel over 60 minutes.
 - Control: Maintain internal temperature <10°C during addition.
- Cyclization: Warm to reflux (75–80°C if 2-MeTHF) and hold for 12 hours.
- Quench: Cool to 20°C. Add water (5 vol) carefully. Separate layers. Wash organic layer with NaHCO₃ (5%) and Brine.[1]
- Isolation: Crystallize from Heptane/EtOAc or Isopropyl Alcohol (IPA).

Step 3: Demethylation to Pyridin-2-ol

- Reagent: Suspend the 1,2,4-oxadiazolyl-2-methoxypyridine in Acetic Acid (5 vol).
- Acidolysis: Add 48% aqueous HBr (5 eq). Heat to 90°C for 4–6 hours.
 - Alternative: For acid-sensitive substrates, use L-Selectride in THF at reflux [4].[2]
- Isolation: Cool to 0°C. Neutralize to pH 6–7 with NaOH (aq). The product (pyridin-2-ol tautomer) typically precipitates. Filter and wash with water.[1]

Protocol B: 1,3,4-Oxadiazole Synthesis

This route is common for 2-pyridone antimicrobial agents.

Key Differences & Hazards

- Hydrazine Hydrate: Used to form the hydrazide. Highly toxic and potential carcinogen. Must be handled in a closed system.[3][4][5]
- Cyclization: Can be achieved using Orthoesters (e.g., triethyl orthoformate) for unsubstituted oxadiazoles, or T3P for substituted ones.

Hydrazone Formation Protocol

- Reactants: Methyl 2-methoxynicotinate (100 g) + Hydrazine Hydrate (3 eq) in Ethanol (5 vol).
- Condition: Reflux 4 h.
- Safety: Distill off excess hydrazine/ethanol under reduced pressure into a chemically treated trap (Bleach quench).
- Isolation: The hydrazone often crystallizes upon cooling. Filter and wash with cold ethanol.

Process Safety & Engineering Controls

Scale-up of oxadiazole chemistry involves significant thermal energy potential.

Heat Flow & T3P Addition

The following diagram illustrates the reactor setup and critical control points (CCPs) for the exothermic cyclization step.

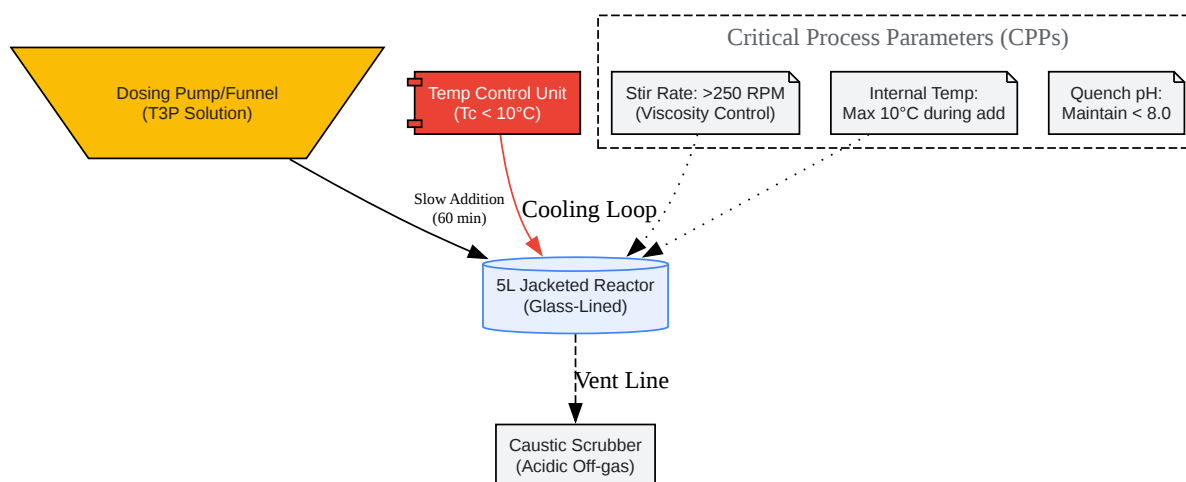

[Click to download full resolution via product page](#)

Figure 2: Reactor Setup for Exothermic T3P Cyclization

Hazard Management Table

Process Step	Hazard	Engineering Control
Amidoxime Formation	Thermal instability of hydroxylamine residue.	Ensure <10 ppm residual NH ₂ OH before drying. DSC test of solid recommended.
T3P Cyclization	Exotherm upon addition; Gas evolution.	Dose controlled by internal temp. Use 2-MeTHF (higher boiling point) to prevent solvent loss.
Demethylation (HBr)	Corrosive fumes; HBr gas.	Scrubber with NaOH. ^[6] Hastelloy or Glass-lined reactor required.
Hydrazine Handling	Carcinogen; Skin absorption.	Closed transfer systems (CTS). Bleach destructor trap for waste.

Analytical Controls

To ensure "Self-Validating" protocols, the following HPLC checkpoints are mandatory:

- IPC 1 (Amidoxime Formation):
 - Method: Reverse Phase C18, Acetonitrile/Water (0.1% TFA).
 - Target: Starting Nitrile < 1.0%.
- IPC 2 (Cyclization):
 - Monitor disappearance of Amidoxime/Hydrazide.
 - Watch for: "Open" intermediate (uncyclized acyl-amidoxime). If present >5%, add more T3P or increase temp.

- Final Purity:
 - Check for N-methylated pyridone impurity (rare with methoxy-route, but possible if MeI is generated in situ during other steps).

References

- GPR119 Agonist Synthesis: Synthesis and biological evaluation of 1,2,4-oxadiazole derivatives as novel GPR119 agonists. PubMed.[7] [Link](#)
- T3P Cyclization: T3P as an efficient cyclodehydration reagent for the one-pot synthesis of 2-amino-1,3,4-oxadiazoles.[8] Indian Academy of Sciences. [Link](#)
- Safety of POCl₃ vs T3P: Optimized POCl₃-assisted synthesis of 2-amino-1,3,4-thiadiazole/1,3,4-oxadiazole derivatives. Arabian Journal of Chemistry. [Link](#)
- Demethylation Strategy: Chemoselective Demethylation of Methoxypyridine using L-Selectride.[2] Synlett. [Link](#)
- Scale-Up Safety: Scale-Up Reaction Safety Guidelines. University of Illinois/Thermo Fisher. [Link](#)

Need Custom Synthesis?

BenchChem offers custom synthesis for rare earth carbides and specific isotopic labeling.

Email: info@benchchem.com or [Request Quote Online](#).

Sources

- 1. Scale-Up Reaction Safety | Division of Research Safety | Illinois [drs.illinois.edu]
- 2. Thieme E-Journals - Synlett / Abstract [thieme-connect.de]
- 3. WERCS Studio - Application Error [assets.thermofisher.com]
- 4. jubilantingrevia.com [jubilantingrevia.com]
- 5. 2-Methoxypyridine(1628-89-3)MSDS Melting Point Boiling Density Storage Transport [m.chemicalbook.com]

- [6. mdpi.com \[mdpi.com\]](#)
- [7. Optimized POCl₃-assisted synthesis of 2-amino-1,3,4-thiadiazole/1,3,4-oxadiazole derivatives as anti-influenza agents - Arabian Journal of Chemistry \[arabjchem.org\]](#)
- [8. ias.ac.in \[ias.ac.in\]](#)
- To cite this document: BenchChem. [Scalable Synthesis of Oxadiazolyl Pyridin-2-ols: Process Development & Safety Controls]. BenchChem, [2026]. [Online PDF]. Available at: [<https://www.benchchem.com/product/b1417832/docs#scalable-synthesis-of-oxadiazolyl-pyridin-2-ols-process-development-safety-controls>]

Disclaimer & Data Validity:

The information provided in this document is for Research Use Only (RUO) and is strictly not intended for diagnostic or therapeutic procedures. While BenchChem strives to provide accurate protocols, we make no warranties, express or implied, regarding the fitness of this product for every specific experimental setup.

Technical Support: The protocols provided are for reference purposes. Unsure if this reagent suits your experiment?

Need Industrial/Bulk Grade? [Request Custom Synthesis Quote](#)

BenchChem

Our mission is to be the trusted global source of essential and advanced chemicals, empowering scientists and researchers to drive progress in science and industry.

Contact

Address: 3281 E Guasti Rd
Ontario, CA 91761, United States
Phone: (601) 213-4426
Email: info@benchchem.com

Contact our Ph.D. Support Team for a compatibility check