

Application Note: Supramolecular Engineering of Benzyl Viologen Host-Guest Complexes

Author: BenchChem Technical Support Team. **Date:** April 2026

Compound of Interest

Compound Name:	<i>1,1'-Dibenzyl-4,4'-bipyridinium Dichloride Hydrate</i>
CAS No.:	<i>141433-62-7</i>
Cat. No.:	<i>B14165833</i>

[Get Quote](#)

Abstract

This technical guide details the synthesis, assembly, and characterization of supramolecular host-guest complexes involving Benzyl Viologen (BV). Focusing on the high-affinity hosts Cucurbit[7]uril (CB[7]) and Cucurbit[8]uril (CB[8]), we provide step-by-step protocols for synthesizing the BV guest, assembling the complexes in aqueous media, and validating the binding stoichiometry and thermodynamics. These systems serve as foundational models for developing redox-responsive molecular switches, drug delivery vehicles, and supramolecular polymers.

Introduction & Mechanistic Rationale

Benzyl Viologen (1,1'-dibenzyl-4,4'-bipyridinium) is a prototypical electron-deficient guest. Its dicationic nature (

) makes it an ideal partner for electron-rich macrocycles. The choice of host dictates the topology and function of the resulting complex:

- CB[7] (The Tight Fit): Possesses a cavity diameter (~7.3 Å) that snugly accommodates the bipyridinium core but excludes the bulky benzyl groups. This results in a highly stable 1:1 binary complex driven by the hydrophobic effect and ion-dipole interactions at the carbonyl portals.^[1]
- CB[8] (The Dimerizer): With a larger cavity (~8.8 Å), CB[8] can accommodate two planar aromatic systems. While it forms 1:1 complexes with BV in dilute solutions, it uniquely supports 1:2 (host:guest) or 2:2 quaternary complexes in the presence of electron-rich second guests (e.g., naphthols) via charge-transfer interactions, or high-concentration dimerization.

Key Applications

- Redox Switching: Encapsulation alters the reduction potential of BV, stabilizing radical cations ().
- Supramolecular Polymerization: Utilizing bifunctional benzyl viologen derivatives to link host cavities.

Materials & Equipment

Reagents

- Precursors: 4,4'-Bipyridine (98%), Benzyl bromide (or Benzyl chloride), Acetonitrile (anhydrous).
- Hosts: Cucurbit[7]uril and Cucurbit[8]uril (commercially available or synthesized via glycoluril-formaldehyde condensation).
- Solvents: Deuterium Oxide () for NMR, ultrapure water (Milli-Q), DMF (for specific solubility needs).

Instrumentation

- NMR Spectrometer: 400 MHz or higher (essential for shift analysis).

- Isothermal Titration Calorimetry (ITC): For thermodynamic parameters ().
- UV-Vis Spectrophotometer: For monitoring charge-transfer bands and binding titrations.

Experimental Protocols

Protocol A: Synthesis of Benzyl Viologen Dichloride (Guest)

Rationale: Commercial BV is available, but in-house synthesis allows for counter-ion control and derivatization.

- Dissolution: Dissolve 4,4'-bipyridine (1.0 eq, 1.56 g, 10 mmol) in anhydrous acetonitrile (50 mL) in a round-bottom flask.
- Alkylation: Add Benzyl chloride (2.5 eq, 3.16 g, 25 mmol) dropwise while stirring.
 - Note: Use Benzyl bromide for faster kinetics, but chloride is preferred if ion-exchange steps are to be avoided later.
- Reflux: Heat the mixture to reflux (C) for 24 hours. The solution will turn yellow/orange, and a precipitate will form.
- Isolation: Cool to room temperature. Filter the precipitate under vacuum.
- Purification: Wash the solid extensively with cold acetonitrile and diethyl ether to remove unreacted precursors.
- Drying: Dry under high vacuum at C for 6 hours.
 - Yield: Typically >85%.
 - Validation:

¹H NMR () should show diagnostic downfield shifts for the pyridinium protons (ppm).

Protocol B: Assembly of Host-Guest Complexes (Titration Method)

Rationale: Supramolecular complexes are dynamic. "Synthesis" is often an equilibrium process. This protocol ensures precise stoichiometric control.

Workflow Diagram: Complex Assembly

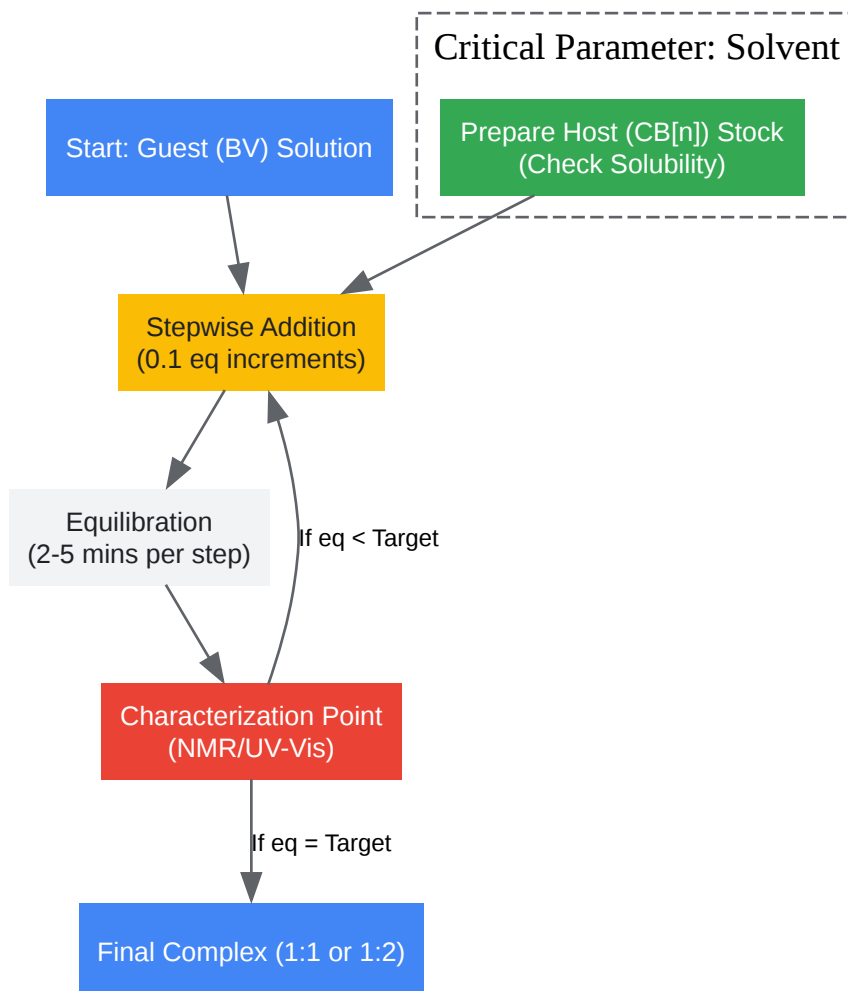

[Click to download full resolution via product page](#)

Caption: Step-wise assembly workflow for controlling host-guest stoichiometry during titration.

Step-by-Step Procedure

- Stock Preparation:
 - Prepare a Guest Stock of Benzyl Viologen () in (for NMR) or water (for UV-Vis).
 - Prepare a Host Stock of CB[7] ().
 - Critical Note: CB[8] has low water solubility (< 0.1 mM). To work with CB[8], use dilute conditions or solubilize in mild acid (0.1 M HCl) or with the help of the guest (add solid host to guest solution).
- Titration:
 - Add Host stock to Guest solution in 0.2 equivalent increments.
 - After each addition, mix thoroughly (vortex) and allow 2 minutes for equilibrium.
- Monitoring (NMR):
 - Observe the -pyridinium protons (ortho to nitrogen).
 - For CB[7]: As host is added, these protons will shift upfield (shielded by the cavity) if the viologen core is included.
 - For CB[8]: Look for broadening or splitting, indicative of intermediate exchange rates or dimerization.

Characterization & Data Analysis

Nuclear Magnetic Resonance (¹H NMR)

NMR is the gold standard for proving inclusion.

Proton Environment	Free BV (ppm)	BV @ CB[7] (ppm)	Shift ()	Interpretation
-Pyridinium	~9.05	~8.10	-0.95	Deep Inclusion: Protons are inside the shielding cone of CB[7].
-Pyridinium	~8.50	~7.30	-1.20	Deep Inclusion: Core is fully encapsulated.
Benzyl ()	~5.90	~5.95	+0.05	Portal Region: Slight deshielding due to carbonyl portal proximity.
Benzyl (Ph)	~7.50	~7.50	~0.00	Exclusion: Phenyl rings remain outside the cavity.

Isothermal Titration Calorimetry (ITC)

ITC provides the thermodynamic profile.

- Setup: Fill cell with BV (0.1 mM), syringe with CB[7] (1.0 mM).
- Expectation:
 - (Exothermic binding).
 - for CB[7]-BV.

- Binding is enthalpy-driven (release of high-energy water from cavity).

Visualization of Interaction Pathways

The following diagram illustrates the divergent pathways for CB[7] vs. CB[8] complexation.

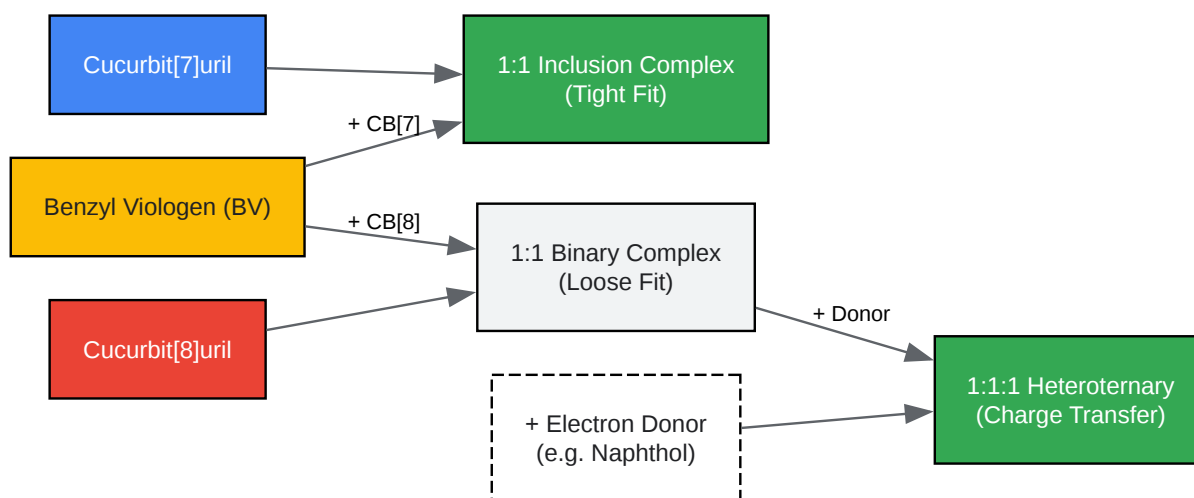

[Click to download full resolution via product page](#)

Caption: Divergent binding modes: CB[7] forms tight 1:1 binaries, while CB[8] enables ternary assemblies.

Troubleshooting & Critical Parameters

- Solubility Issues (CB[8]):
 - Problem: CB[8] precipitates during titration.
 - Solution: Use the "Solid Host" method. Add weighed amounts of solid CB[8] directly to the guest solution and sonicate. The complex is often more soluble than the free host.
- Fast vs. Slow Exchange (NMR):
 - Observation: Broad peaks instead of sharp shifted peaks.
 - Cause: Binding kinetics are on the intermediate NMR time scale.

- Fix: Run NMR at variable temperatures (VT-NMR). Heating usually sharpens peaks by accelerating exchange; cooling may freeze out the bound/free states.
- Counter-ion Effects:
 - Chloride salts are standard. However, bulky counter-ions (e.g.,
) drastically reduce water solubility, necessitating organic solvents (DMSO/Acetonitrile) where binding constants (
) will drop significantly due to solvent competition.

References

- Kim, K., et al. (2002). "Cucurbit[7]uril: A Very Effective Host for Viologens and Their Cation Radicals." [2] Organic Letters. [Link](#)
- Scherman, O. A., et al. (2017). "Mining 2:2 Complexes from 1:1 Stoichiometry: Formation of Cucurbit[8]uril–Diarylviologen Quaternary Complexes." Journal of the American Chemical Society. [Link](#)
- Kaifer, A. E., et al. (2004). "Modes of binding interaction between viologen guests and the cucurbit[7]uril host." [1][3] Journal of Organic Chemistry. [Link](#)
- Masson, E., et al. (2012). "Cucurbituril Chemistry: A Tale of High-Affinity Binding and Selectivity." RSC Advances. [Link](#)
- Liu, J., et al. (2023). [4] "Supramolecular Host-Guest Hydrogel Based on γ -Cyclodextrin and Carboxybenzyl Viologen." ACS Applied Materials & Interfaces. [5][6][7] [Link](#)[6]

Need Custom Synthesis?

BenchChem offers custom synthesis for rare earth carbides and specific isotopic labeling.

Email: info@benchchem.com or [Request Quote Online](#).

Sources

- [1. researchgate.net \[researchgate.net\]](https://www.researchgate.net)
- [2. Cucurbit\[7\]uril: a very effective host for viologens and their cation radicals - PubMed \[pubmed.ncbi.nlm.nih.gov\]](https://pubmed.ncbi.nlm.nih.gov/)
- [3. arts.units.it \[arts.units.it\]](https://arts.units.it)
- [4. pubs.acs.org \[pubs.acs.org\]](https://pubs.acs.org)
- [5. researchgate.net \[researchgate.net\]](https://www.researchgate.net)
- [6. pubs.acs.org \[pubs.acs.org\]](https://pubs.acs.org)
- [7. Supramolecular Host-Guest Hydrogel Based on \$\gamma\$ -Cyclodextrin and Carboxybenzyl Viologen Showing Reversible Photochromism and Photomodulable Fluorescence - PubMed \[pubmed.ncbi.nlm.nih.gov\]](https://pubmed.ncbi.nlm.nih.gov/)
- To cite this document: BenchChem. [Application Note: Supramolecular Engineering of Benzyl Viologen Host-Guest Complexes]. BenchChem, [2026]. [Online PDF]. Available at: [\[https://www.benchchem.com/product/b14165833/docs#application-note-supramolecular-engineering-of-benzyl-viologen-host-guest-complexes\]](https://www.benchchem.com/product/b14165833/docs#application-note-supramolecular-engineering-of-benzyl-viologen-host-guest-complexes)

Disclaimer & Data Validity:

The information provided in this document is for Research Use Only (RUO) and is strictly not intended for diagnostic or therapeutic procedures. While BenchChem strives to provide accurate protocols, we make no warranties, express or implied, regarding the fitness of this product for every specific experimental setup.

Technical Support: The protocols provided are for reference purposes. Unsure if this reagent suits your experiment?

Need Industrial/Bulk Grade? [Request Custom Synthesis Quote](#)

BenchChem

Our mission is to be the trusted global source of essential and advanced chemicals, empowering scientists and researchers to drive progress in science and industry.

Contact

Address: 3281 E Guasti Rd
Ontario, CA 91761, United States
Phone: (601) 213-4426
Email: info@benchchem.com

Contact our Ph.D. Support Team for a compatibility check