

Application Notes & Protocols: Stereoselective Bromination of Phenylpropynone Derivatives

Author: BenchChem Technical Support Team. **Date:** April 2026

Compound of Interest

Compound Name: *2-Propyn-1-one, 3-bromo-1-phenyl-*

CAS No.: 3876-61-7

Cat. No.: B14151371

[Get Quote](#)

Abstract

This document provides a comprehensive guide for the stereoselective bromination of phenylpropynone derivatives, a critical transformation in the synthesis of valuable chemical intermediates. Phenylpropynone, an aromatic ketone with an alkyne functionality, serves as a versatile scaffold. Its bromination opens pathways to a variety of di- and tetra-halogenated compounds, which are precursors for cross-coupling reactions, heterocyclic synthesis, and the development of novel pharmaceutical agents. This guide details multiple protocols, covering classical electrophilic additions to achieve (E)-isomers and modern catalytic methods for accessing both (E)- and (Z)-dibromoalkenes. We delve into the underlying reaction mechanisms, provide step-by-step experimental procedures, and offer expert insights into safety, characterization, and troubleshooting.

Critical Safety Precautions

WARNING: Bromine (Br₂) is a highly toxic, corrosive, and volatile substance.[1][2] Inhalation can be fatal, and direct contact causes severe chemical burns.[1][3] All manipulations involving

liquid bromine or concentrated solutions must be performed in a certified chemical fume hood.

- Personal Protective Equipment (PPE): Always wear chemical-resistant gloves (nitrile is acceptable for incidental contact, but heavyweight butyl rubber or Viton is recommended for handling pure bromine), a flame-retardant lab coat, and chemical splash goggles with a full-face shield.[\[2\]](#)[\[4\]](#)
- Ventilation: Ensure adequate ventilation. Operations with liquid bromine should exclusively take place within a fume hood.[\[2\]](#)
- Spill Management: Keep a bromine spill kit readily accessible. This should include an aqueous solution of sodium thiosulfate or sodium carbonate (1 M) to neutralize bromine spills.[\[1\]](#) In case of a spill, evacuate the area and follow institutional safety protocols.
- First Aid:
 - Inhalation: Move the affected person to fresh air immediately and seek emergency medical attention.[\[5\]](#)
 - Skin Contact: Remove contaminated clothing and flush the affected skin with copious amounts of water for at least 20 minutes, followed by washing with soap and water.[\[5\]](#)
 - Eye Contact: Immediately flush eyes with gently running water for at least 20 minutes.[\[1\]](#)
 - Ingestion: Do not induce vomiting. Seek immediate medical attention.[\[5\]](#)
- Alternative Reagents: Due to the hazards of Br₂, consider using safer alternatives like N-Bromosuccinimide (NBS) or Copper(II) Bromide (CuBr₂), for which protocols are provided below.[\[6\]](#)[\[7\]](#)

Theoretical Background & Mechanistic Insights

The bromination of the alkyne moiety in phenylpropynone derivatives is primarily an electrophilic addition reaction. The stereochemical outcome of this addition is highly dependent on the reagents and reaction conditions.

Electrophilic Addition of Br₂: The Path to (E)-Dibromoalkenes

The reaction of an alkyne with one equivalent of molecular bromine typically proceeds via an anti-addition mechanism, yielding the (E)-dihaloalkene as the major product.^{[8][9]}

The mechanism involves two key steps:

- **Formation of a Cyclic Bromonium Ion:** The electron-rich π -system of the alkyne attacks a bromine molecule, which becomes polarized upon approach. This leads to the formation of a three-membered cyclic bromonium ion intermediate and a bromide ion (Br^-).^{[8][9][10]}
- **Nucleophilic Attack:** The bromide ion then attacks one of the carbons of the bromonium ion from the side opposite the existing C-Br bond (backside attack), in a process analogous to an $\text{S}_{\text{N}}2$ reaction.^{[8][9]} This backside attack forces the ring to open and results in the two bromine atoms being on opposite sides of the newly formed double bond, leading to the (E)-stereoisomer.

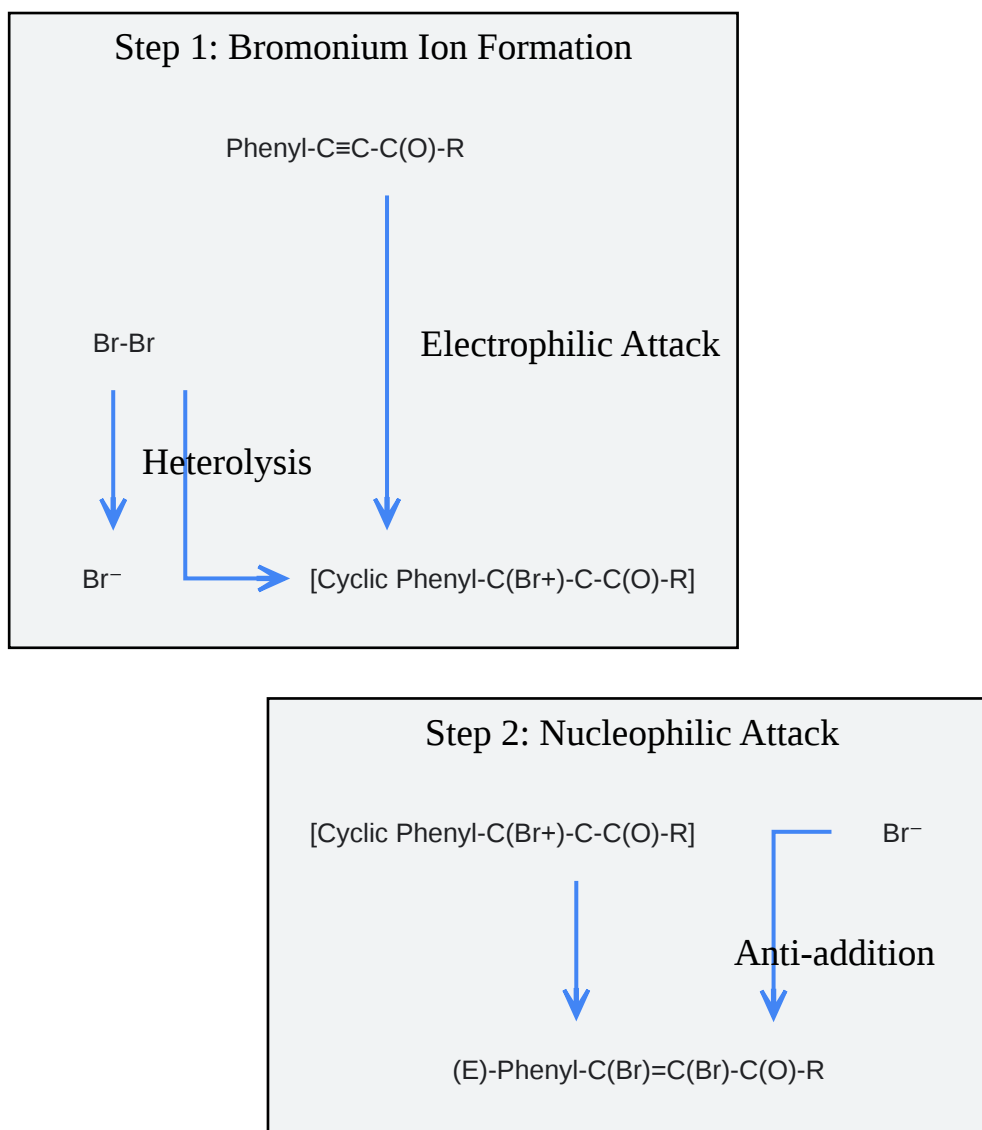

[Click to download full resolution via product page](#)

Caption: Mechanism of electrophilic anti-addition of Br₂ to an alkyne.

Stereoselective Control: Accessing (Z)-Isomers and Safer (E)-Synthesis

While classical bromination yields (E)-isomers, modern synthetic methods offer greater control and safety.

- (E)-Selective Synthesis with CuBr_2 : Copper(II) bromide can serve as both the bromine source and a catalyst, providing a highly stereoselective route to (E)-dibromoalkenes under mild conditions.[6][11] This method avoids the use of hazardous liquid bromine and often tolerates a wider range of functional groups.[6][7][11] The mechanism is proposed to involve a copper(II)- π complex.[6]
- Stereodivergent Synthesis with NBS: N-Bromosuccinimide (NBS) is a solid, easy-to-handle brominating agent. Its reactivity can be tuned with catalysts to produce either the (Z) or (E) isomer.
 - For (Z)-Dibromoalkenes: An unprecedented $\text{Ag}-\text{CH}_3\text{SO}_3\text{H}$ co-catalyzed system using NBS has been developed for the direct synthesis of (Z)-1,2-dibromoalkenes. The mechanism is believed to proceed through a silver allene cation intermediate followed by bromine radical addition.
 - For (E)-Dibromoalkenes: A triphenylphosphine (PPh_3)-promoted reaction with NBS also provides the (E)-isomer, proceeding through a bromonium ion intermediate.

Experimental Protocols

Protocol 1: Classical Electrophilic Bromination for (E)-Isomers

Principle: This protocol uses liquid bromine in an inert solvent for the direct anti-addition across the alkyne, yielding the (E)-dibromo-phenylpropenone.

| Materials & Reagents | Specifications |
|---|----------------------|
| Phenylpropynone Derivative | 1.0 eq |
| Bromine (Br ₂) | 1.0 - 1.1 eq |
| Dichloromethane (DCM) | Anhydrous, ACS Grade |
| Saturated Sodium Bicarbonate (NaHCO ₃) | Aqueous Solution |
| Saturated Sodium Thiosulfate (Na ₂ S ₂ O ₃) | Aqueous Solution |
| Anhydrous Magnesium Sulfate (MgSO ₄) | ACS Grade |
| Round-bottom flask, dropping funnel | Standard glassware |

Procedure:

- **Setup:** In a fume hood, dissolve the phenylpropynone derivative (1.0 eq) in anhydrous dichloromethane (DCM, approx. 0.1 M concentration) in a round-bottom flask equipped with a magnetic stir bar. Cool the solution to 0 °C using an ice bath.
- **Reagent Preparation:** In a separate container, prepare a solution of bromine (1.05 eq) in a small amount of DCM.
 - **Scientist's Note:** Preparing a dilute solution of bromine and adding it dropwise helps to control the reaction rate and dissipate the heat generated, preventing potential side reactions.
- **Reaction:** Add the bromine solution to the stirred phenylpropynone solution dropwise via a dropping funnel over 30-60 minutes. Maintain the temperature at 0 °C. The characteristic reddish-brown color of bromine should disappear as it is consumed.
- **Monitoring:** Monitor the reaction progress by Thin Layer Chromatography (TLC). The reaction is typically complete when the starting material spot is no longer visible.
- **Quenching:** Once the reaction is complete, quench any excess bromine by slowly adding saturated sodium thiosulfate solution until the reddish-brown color completely vanishes.

- **Work-up:** Transfer the reaction mixture to a separatory funnel. Wash the organic layer sequentially with saturated sodium bicarbonate solution (1x) and brine (1x).
- **Drying and Concentration:** Dry the organic layer over anhydrous magnesium sulfate, filter, and concentrate the solvent under reduced pressure using a rotary evaporator.
- **Purification:** Purify the crude product by column chromatography on silica gel or recrystallization to obtain the pure (E)-1,2-dibromo-1-phenylprop-2-en-1-one derivative.

Protocol 2: Copper-Catalyzed Bromination for (E)-Isomers

Principle: This safer protocol uses solid CuBr_2 as the bromine source and catalyst in acetonitrile, providing high stereoselectivity for the (E)-isomer under mild conditions.[6][11]

| Materials & Reagents | Specifications |
|--|----------------------|
| Phenylpropynone Derivative | 1.0 eq |
| Copper(II) Bromide (CuBr_2) | 2.2 eq |
| Acetonitrile (MeCN) | Anhydrous, ACS Grade |
| Molecular Sieves (4Å) | Activated |
| Ethyl Acetate (EtOAc) | ACS Grade |
| Saturated Ammonium Chloride (NH_4Cl) | Aqueous Solution |
| Anhydrous Sodium Sulfate (Na_2SO_4) | ACS Grade |

Procedure:

- **Setup:** To an oven-dried round-bottom flask, add the phenylpropynone derivative (1.0 eq), copper(II) bromide (2.2 eq), and activated 4Å molecular sieves.
 - **Scientist's Note:** Molecular sieves are added to scavenge any trace amounts of water, which can lead to side reactions and reduced yields.[11]

- **Reaction:** Add anhydrous acetonitrile and stir the mixture at room temperature or a slightly elevated temperature (e.g., 40-60 °C) as required for the specific substrate.
- **Monitoring:** Monitor the reaction by TLC until the starting material is consumed. Reaction times can vary from a few hours to 24 hours.
- **Work-up:** After completion, cool the reaction to room temperature and filter the mixture through a pad of Celite to remove the copper salts and molecular sieves. Rinse the pad with ethyl acetate.
- **Extraction:** Transfer the filtrate to a separatory funnel and wash with saturated ammonium chloride solution (2x) to remove any remaining copper salts, followed by a brine wash (1x).
- **Drying and Concentration:** Dry the organic layer over anhydrous sodium sulfate, filter, and remove the solvent under reduced pressure.
- **Purification:** Purify the crude product by column chromatography on silica gel to yield the pure (E)-dibrominated product.

Caption: General workflow for the CuBr₂-mediated bromination protocol.

Characterization of Products

The resulting dibromo-phenylpropenone derivatives can be characterized using standard analytical techniques.

| Technique | Expected Observations for (E)-1,2-dibromo-1-phenylprop-2-en-1-one |
|---------------------|---|
| ¹ H NMR | The vinylic proton signal will be absent. Aromatic protons will appear in the δ 7.4-8.0 ppm region. The pattern will depend on the substitution of the phenyl ring. |
| ¹³ C NMR | Two olefinic carbons bonded to bromine will appear in the δ 110-130 ppm range. The carbonyl carbon (C=O) will be significantly downfield ($\delta > 180$ ppm). Aromatic carbons will be observed in their typical region (δ 125-140 ppm). |
| Mass Spec (EI-MS) | The mass spectrum will show a characteristic isotopic pattern for two bromine atoms ($[M]^+$, $[M+2]^+$, $[M+4]^+$ with a ratio of approximately 1:2:1). [12] |

Troubleshooting

| Problem | Possible Cause(s) | Suggested Solution(s) |
|--------------------------------|---|---|
| Incomplete Reaction | Insufficient reagent; Low reaction temperature or time; Deactivated substrate. | Add a slight excess of the brominating agent (e.g., 1.1 eq). Increase reaction time or temperature moderately. For deactivated substrates (with electron-withdrawing groups), longer reaction times may be necessary. |
| Low Yield | Side reactions (e.g., addition of a second equivalent of Br ₂); Product loss during work-up; Substrate decomposition. | Ensure slow, controlled addition of Br ₂ at low temperature. Be meticulous during the extraction and purification steps. Use milder conditions or alternative reagents like NBS or CuBr ₂ . |
| Mixture of (E) and (Z) Isomers | Reaction mechanism is not exclusively anti-addition; Isomerization of the product. | For high (E)-selectivity, the CuBr ₂ method is recommended. ^{[6][11]} For (Z)-selectivity, the specific Ag-catalyzed NBS protocol is required. |
| Formation of Tetrabromo Adduct | Excess brominating agent used. | Use exactly one equivalent of the brominating agent. Monitor the reaction carefully by TLC and quench immediately upon consumption of the starting material. |

References

- Chemistry LibreTexts. (2024, March 24). 9.3: Reactions of Alkynes - Addition of HX and X₂. [\[Link\]](#)
- Lumen Learning. Reactions of Alkynes: Addition of HX and (X₂). [\[Link\]](#)

- Wang, W., et al. (2023). Stereoselective synthesis of (Z/E)-1,2-dibromoalkenes from terminal alkynes. *Organic Chemistry Frontiers*, 10, 3903-3908. [[Link](#)]
- CLEAPSS. (2022). Student safety sheets 55 Bromine. [[Link](#)]
- Chem-Safety. (2025, October 20). Safety & Handling Guidelines for Bromine and Bromide Chemicals in Export Operations. [[Link](#)]
- Slideshare. Bromine handling and safety. [[Link](#)]
- Xiang, J., et al. (2014). Method for Transforming Alkynes into (E)-Dibromoalkenes. *The Journal of Organic Chemistry*, 79(23), 11378–11382. [[Link](#)]
- Carl ROTH. Safety Data Sheet: Bromine. [[Link](#)]
- National Center for Biotechnology Information. (n.d.). Halogenase-Assisted Alkyne/Aryl Bromide Sonogashira Coupling for Ribosomally Synthesized Peptides. PMC. [[Link](#)]
- Centers for Disease Control and Prevention. (2024, September 6). Bromine. Chemical Emergencies. [[Link](#)]
- Chemistry LibreTexts. (2023, January 22). Electrophilic Addition Reactions of Alkynes. [[Link](#)]
- Knochel, P., et al. (2024, November 9). Chemoselective Preparation of Alkynes from Vicinal and Geminal Dibromoalkenes. *The Journal of Organic Chemistry*. [[Link](#)]
- Organic Chemistry Portal. Method for Transforming Alkynes into (E)-Dibromoalkenes. [[Link](#)]
- OpenStax. (2023, September 20). 9.3 Reactions of Alkynes: Addition of HX and X₂. [[Link](#)]
- Organic Chemistry Portal. Dibromoalkene synthesis by bromination or substitution. [[Link](#)]
- Ashenhurst, J. (2025, December 12). Alkyne Halogenation: Bromination and Chlorination of Alkynes. *Master Organic Chemistry*. [[Link](#)]
- Neuman, R. C. (n.d.). 10: Alkenes and Alkynes. Electrophilic and Concerted Addition Reactions. [[Link](#)]

- ChemTalk. (2023, October 15). Alkyne Addition Reactions. [[Link](#)]
- Lumen Learning. 10.5. Simple addition to alkynes. Organic Chemistry 1: An open textbook. [[Link](#)]
- Lumen Learning. 10.5. Simple addition to alkynes. Organic Chemistry II. [[Link](#)]
- Chemistry LibreTexts. (2019, June 5). 11.8: Addition of Halogen to Alkynes. [[Link](#)]
- Royal Society of Chemistry. (2023). Stereoselective synthesis of (Z/E)-1,2-dibromoalkenes from terminal alkynes. [[Link](#)]
- Rizwan, K., et al. (n.d.). Facile synthesis of N- (4-bromophenyl)-1- (3-bromothiophen-2-yl)methanimine derivatives via Suzuki cross-coupling reaction. PMC. [[Link](#)]

Need Custom Synthesis?

BenchChem offers custom synthesis for rare earth carbides and specific isotopic labeling.

Email: info@benchchem.com or [Request Quote Online](#).

Sources

1. science.cleapss.org.uk [science.cleapss.org.uk]
2. dollycorporation.com [dollycorporation.com]
3. Bromine handling and safety | DOCX [slideshare.net]
4. carloth.com [carloth.com]
5. Bromine | Chemical Emergencies | CDC [cdc.gov]
6. pubs.acs.org [pubs.acs.org]
7. Dibromoalkene synthesis by bromination or substitution [organic-chemistry.org]
8. chem.libretexts.org [chem.libretexts.org]
9. masterorganicchemistry.com [masterorganicchemistry.com]
10. chem.libretexts.org [chem.libretexts.org]
11. Method for Transforming Alkynes into (E)-Dibromoalkenes [organic-chemistry.org]

- [12. Facile synthesis of N- \(4-bromophenyl\)-1- \(3-bromothiophen-2-yl\)methanimine derivatives via Suzuki cross-coupling reaction: their characterization and DFT studies - PMC \[pmc.ncbi.nlm.nih.gov\]](#)
- To cite this document: BenchChem. [Application Notes & Protocols: Stereoselective Bromination of Phenylpropynone Derivatives]. BenchChem, [2026]. [Online PDF]. Available at: [<https://www.benchchem.com/product/b14151371/docs#application-notes-protocols-stereoselective-bromination-of-phenylpropynone-derivatives>]

Disclaimer & Data Validity:

The information provided in this document is for Research Use Only (RUO) and is strictly not intended for diagnostic or therapeutic procedures. While BenchChem strives to provide accurate protocols, we make no warranties, express or implied, regarding the fitness of this product for every specific experimental setup.

Technical Support: The protocols provided are for reference purposes. Unsure if this reagent suits your experiment?

Need Industrial/Bulk Grade? [Request Custom Synthesis Quote](#)

BenchChem

Our mission is to be the trusted global source of essential and advanced chemicals, empowering scientists and researchers to drive progress in science and industry.

Contact

Address: 3281 E Guasti Rd
Ontario, CA 91761, United States
Phone: (601) 213-4426
Email: info@benchchem.com

[Contact our Ph.D. Support Team for a compatibility check](#)

