

# Application Note: Strategic Design and Evaluation of Pyridine-Based Kinase Inhibitors

**Author:** BenchChem Technical Support Team. **Date:** May 2026

## Compound of Interest

Compound Name: *3-Difluoromethoxy-5-(trifluoromethyl)pyridine*

CAS No.: *1803850-92-1*

Cat. No.: *B1413117*

[Get Quote](#)

## Abstract

The pyridine ring is a cornerstone pharmacophore in kinase inhibitor discovery, serving as a bioisostere for the adenine ring of ATP. Its ability to accept hydrogen bonds from the kinase hinge region makes it a privileged scaffold for Type I and Type II inhibitors. This application note provides a comprehensive guide for researchers developing pyridine-based inhibitors. It covers rational structure-activity relationship (SAR) design, a robust Suzuki-Miyaura cross-coupling protocol optimized for electron-deficient heterocycles, and a validated ADP-Glo™ biochemical assay for potency determination.

## Part 1: Rational Design & SAR Strategy

### The Hinge Binding Hypothesis

The primary function of the pyridine scaffold in kinase inhibition is to mimic the purine core of ATP. In the ATP-binding pocket, the "hinge region" connects the N-terminal and C-terminal lobes of the kinase.[1]

- Mechanism: The nitrogen atom of the pyridine ring typically acts as a Hydrogen Bond Acceptor.
- Target Interaction: It forms a critical hydrogen bond with the backbone amide (NH) of the hinge region residues (often denoted as Gatekeeper+1 or Gatekeeper+3 depending on the specific kinase).
- Substitution Logic:
  - C2/C6 Positions: Substituents here can clash with the "gatekeeper" residue or solvent front. Small groups (-NH<sub>2</sub>, -F) are tolerated; bulky groups often induce a "Type II" binding mode (inactive conformation).
  - C3/C5 Positions: Ideal vectors for solubilizing groups (e.g., piperazine tails) that extend into the solvent-exposed region.

## Visualization of Binding Mode

The following diagram illustrates the canonical interaction between a pyridine-based inhibitor and the kinase hinge region.

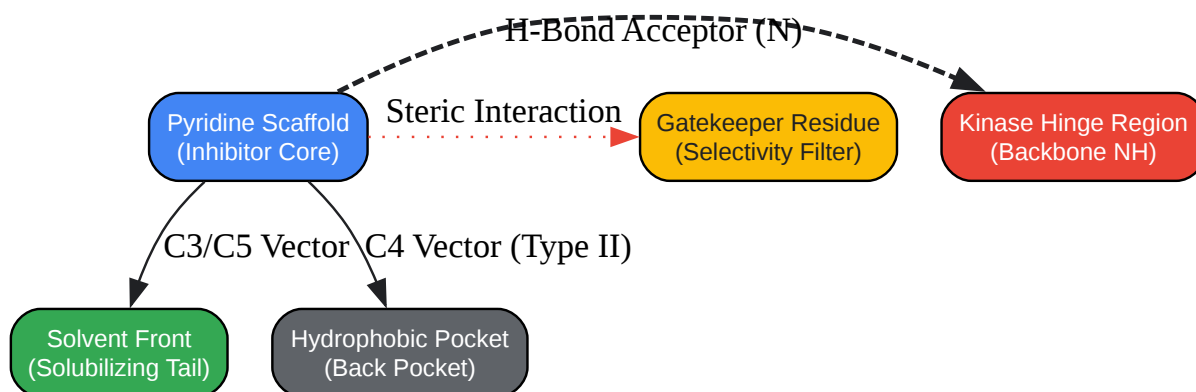

[Click to download full resolution via product page](#)

Figure 1: Canonical binding interactions of a pyridine scaffold within the ATP-binding pocket.

## Part 2: Synthetic Protocol (The "Make")

## Challenge: Pyridine Boronates vs. Halides

Synthesizing pyridine scaffolds via Suzuki-Miyaura coupling presents a specific challenge: Protodeboronation. Pyridine-2-boronic acids are notoriously unstable.

- Strategic Choice: It is chemically superior to use a Pyridine-Halide (electrophile) coupled with a stable Aryl-Boronate (nucleophile).

## Optimized Protocol: Pd-Catalyzed Cross-Coupling

This protocol uses Pd(dppf)Cl<sub>2</sub> which resists chelation by the pyridine nitrogen, a common cause of catalyst deactivation.

Reagents:

- Substrate A: 2-Chloro-N-substituted-pyridine-carboxamide (1.0 equiv)
- Substrate B: Aryl boronic acid pinacol ester (1.2 equiv)
- Catalyst: Pd(dppf)Cl<sub>2</sub>·DCM (0.05 equiv)
- Base: 2M Aqueous Na<sub>2</sub>CO<sub>3</sub> (3.0 equiv)
- Solvent: 1,4-Dioxane (degassed)

Step-by-Step Procedure:

- Preparation: In a microwave vial, dissolve Substrate A and Substrate B in 1,4-Dioxane (concentration ~0.2 M).
- Degassing: Sparge the solution with Argon for 5 minutes. Critical: Oxygen poisons the Pd(0) species.
- Activation: Add the Base (2M Na<sub>2</sub>CO<sub>3</sub>) and the Catalyst (Pd(dppf)Cl<sub>2</sub>).
- Reaction: Seal the vial and heat to 90°C for 4-12 hours. (Monitor via LC-MS).
- Work-up:

- Cool to room temperature.[4][5]
- Filter through a Celite pad to remove Palladium black.
- Dilute with EtOAc, wash with brine, and dry over MgSO<sub>4</sub>.
- Purification: Flash chromatography (Hexane/EtOAc gradient). Pyridines often streak on silica; add 1% Triethylamine to the eluent if necessary.

## Part 3: Biochemical Profiling (The "Test")

### Assay Selection: ADP-Glo™ Kinase Assay

To evaluate the potency (IC<sub>50</sub>) of the synthesized inhibitors, we utilize the ADP-Glo™ assay. This is a homogeneous, luminescent assay that measures ADP formation, directly correlating to kinase activity.[6][7][8]

Why this assay?

- Universal: Works for any kinase.
- High Dynamic Range: Detects low conversion rates, essential for high-affinity inhibitors.
- Interference-Free: The luminescence readout is less susceptible to compound autofluorescence compared to FRET.

## Experimental Workflow

The assay follows a 1:1:2 volume ratio principle.[4]

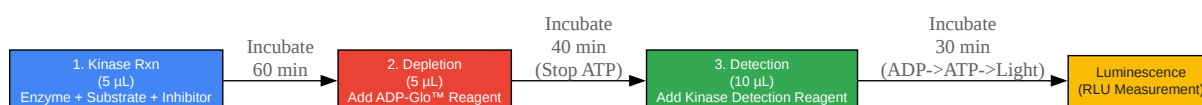

[Click to download full resolution via product page](#)

Figure 2: ADP-Glo™ Assay Workflow. Note the specific incubation times required for ATP depletion.

## Detailed Protocol

- Compound Preparation:
  - Prepare 3-fold serial dilutions of the pyridine inhibitor in 100% DMSO (10-point curve).
  - Dilute into 1X Kinase Buffer (final DMSO concentration should be <1%).
- Kinase Reaction (Step 1):
  - Add 2  $\mu$ L of Inhibitor to a 384-well white low-volume plate.
  - Add 2  $\mu$ L of Kinase Enzyme (optimized concentration, typically 1-10 ng/well).
  - Add 1  $\mu$ L of ATP/Substrate mix (ATP concentration should be at   
 ).
  - Control 1 (Max Signal): DMSO + Enzyme + Substrate.
  - Control 2 (Min Signal): DMSO + Buffer (No Enzyme).
  - Incubate at Room Temp for 60 minutes.
- ADP-Glo Reagent Addition (Step 2):
  - Add 5  $\mu$ L of ADP-Glo™ Reagent.[4]
  - Incubate for 40 minutes. Mechanism: This stops the kinase reaction and depletes all unconsumed ATP.[4][7]
- Detection Reagent Addition (Step 3):
  - Add 10  $\mu$ L of Kinase Detection Reagent.[4]
  - Incubate for 30 minutes. Mechanism: Converts generated ADP back to ATP, which drives the Luciferase reaction.
- Data Acquisition:

- Read Luminescence (Integration time: 0.5 - 1.0 sec).

## Data Analysis & Quality Control

Calculate the Z-Factor to validate the assay quality before analyzing IC50.

Parameter	Acceptance Criteria	Action if Failed
Z-Factor	> 0.5 (Ideal > 0.7)	Check pipetting error or reagent stability.
Signal:Background	> 3-fold	Increase enzyme concentration or reaction time.
IC50 Fit	Hill Slope ~ 1.0	Check for compound aggregation or non-specific binding.

## References

- National Center for Biotechnology Information (NCBI). "Assay Development for Protein Kinase Enzymes." Assay Guidance Manual. [[Link](#)]
- Yoneda Labs. "Suzuki-Miyaura Cross-Coupling: Practical Guide." [[Link](#)]
- American Chemical Society (ACS). "Development of Pyridine-based Inhibitors for Human Vaccinia-related Kinases." Journal of Medicinal Chemistry. [[Link](#)]

### Need Custom Synthesis?

BenchChem offers custom synthesis for rare earth carbides and specific isotopic labeling.

Email: [info@benchchem.com](mailto:info@benchchem.com) or [Request Quote Online](#).

## Sources

- [1. How protein kinase inhibitors bind to the hinge region of the target protein - PMC \[pmc.ncbi.nlm.nih.gov\]](#)

- [2. Synthesis of 2-arylpyridines by the Suzuki–Miyaura cross-coupling of PyFluor with hetero\(aryl\) boronic acids and esters - PMC \[pmc.ncbi.nlm.nih.gov\]](#)
- [3. books.rsc.org \[books.rsc.org\]](#)
- [4. promega.com \[promega.com\]](#)
- [5. pdf.benchchem.com \[pdf.benchchem.com\]](#)
- [6. researchgate.net \[researchgate.net\]](#)
- [7. ADP-Glo™ Kinase Assay Protocol \[worldwide.promega.com\]](#)
- [8. ADP-Glo™ Kinase Assay \[promega.sg\]](#)
- To cite this document: BenchChem. [Application Note: Strategic Design and Evaluation of Pyridine-Based Kinase Inhibitors]. BenchChem, [2026]. [Online PDF]. Available at: [\[https://www.benchchem.com/product/b1413117/docs#application-note-strategic-design-and-evaluation-of-pyridine-based-kinase-inhibitors\]](https://www.benchchem.com/product/b1413117/docs#application-note-strategic-design-and-evaluation-of-pyridine-based-kinase-inhibitors)

---

#### Disclaimer & Data Validity:

The information provided in this document is for Research Use Only (RUO) and is strictly not intended for diagnostic or therapeutic procedures. While BenchChem strives to provide accurate protocols, we make no warranties, express or implied, regarding the fitness of this product for every specific experimental setup.

**Technical Support:** The protocols provided are for reference purposes. Unsure if this reagent suits your experiment?

**Need Industrial/Bulk Grade?** [Request Custom Synthesis Quote](#)

## BenchChem

Our mission is to be the trusted global source of essential and advanced chemicals, empowering scientists and researchers to drive progress in science and industry.

#### Contact

Address: 3281 E Guasti Rd

Ontario, CA 91761, United States

Phone: (601) 213-4426

Email: [info@benchchem.com](mailto:info@benchchem.com)

Contact our Ph.D. Support Team for a compatibility check