

Application Notes and Protocols for Potassium Phosphite in Integrated Pest Management

Author: BenchChem Technical Support Team. **Date:** May 2026

Compound of Interest

Compound Name: Potassium;phosphite

Cat. No.: B14129421

[Get Quote](#)

For Researchers, Scientists, and Drug Development Professionals

These application notes provide a comprehensive overview of the use of potassium phosphite in Integrated Pest Management (IPM) programs. The information compiled here is intended to guide research and development efforts by detailing the mechanisms of action, providing standardized experimental protocols, and presenting quantitative data on its efficacy.

Introduction to Potassium Phosphite in IPM

Potassium phosphite (KPhi), a salt of phosphorous acid, is a valuable tool in modern agriculture, functioning as both a biostimulant and a fungicide.[1][2] Unlike traditional phosphate fertilizers, which provide phosphorus in the +5 oxidation state, phosphite contains phosphorus in the +3 state.[3] This chemical distinction is crucial as phosphite is not readily metabolized by plants as a primary phosphorus source but is highly mobile within the plant, moving systemically through both the xylem and phloem.[4][5] Its role in IPM is multifaceted, offering both direct antimicrobial action and, more significantly, the induction of the plant's innate defense systems.[5][6]

Mechanism of Action

Potassium phosphite employs a dual-action mechanism to protect plants from pathogens, particularly Oomycetes like Phytophthora and Pythium, as well as some fungi and bacteria.[3][5][7]

- **Direct Action:** At higher concentrations, phosphite directly inhibits the growth of certain pathogens.[5] It can interfere with fungal spore formation and disrupt cell wall development.[3] This direct fungistatic effect provides a first line of defense against invading pathogens.
- **Indirect Action (Induction of Plant Defenses):** The primary and more lauded mechanism of potassium phosphite is its ability to act as a "plant vaccine" by priming the plant's immune system.[3] It triggers Systemic Acquired Resistance (SAR), a state of heightened defense readiness throughout the plant.[3][4] This induced resistance is characterized by a cascade of physiological and biochemical changes:
 - **Activation of Signaling Pathways:** Potassium phosphite treatment has been shown to activate the salicylic acid (SA) signaling pathway, a key regulator of SAR.[8][9] This leads to the expression of defense-related transcription factors like StNPR1 and StWRKY1 in potato.[10]
 - **Production of Defense Molecules:** The activation of these pathways results in the synthesis and accumulation of various defense compounds, including:
 - **Phytoalexins and Phenolic Compounds:** These antimicrobial compounds restrict pathogen growth.[3][11]
 - **Pathogenesis-Related (PR) Proteins:** Such as chitinases and glucanases, which can degrade fungal cell walls.[3][7]
 - **Reactive Oxygen Species (ROS):** Molecules like hydrogen peroxide and superoxide anion are produced, which can have direct antimicrobial effects and also act as signaling molecules.[3][10]
 - **Structural Reinforcement:** Potassium phosphite promotes the thickening of cell walls through the deposition of lignin, callose, and suberin, creating a stronger physical barrier against pathogen penetration.[1][3][6]

Data Presentation: Efficacy and Application Rates

The following tables summarize quantitative data on the efficacy of potassium phosphite against various pathogens and provide general application guidelines.

Table 1: Efficacy of Potassium Phosphite Against Plant Pathogens

Pathogen	Host Plant	Application Method	Efficacy	Reference
Colletotrichum lindemuthianum (Anthracnose)	Bean	Foliar Spray (5 mL/L)	42% reduction in mycelial growth, 48% reduction in germination, 17% reduction in disease severity	[7]
Colletotrichum gloeosporioides (Anthracnose)	Coffee	In vitro	62.5% reduction in disease severity (at 10.0 mL/L)	[12]
Phytophthora infestans (Late Blight)	Potato	Foliar Spray (in combination with reduced-dose fungicides)	Significant reduction in disease severity (up to ~90%)	[13][14]
Pseudomonas syringae pv. tomato (Bacterial Speck)	Tomato	Foliar Spray	42.1-75.0% inhibition of symptoms (first experiment), 22.8-90.3% inhibition (second experiment)	[15]
Penicillium digitatum (Green Mold)	Citrus (postharvest)	Fruit Immersion (20 g/L at 50°C)	Significant reduction in mold incidence	[16]

Table 2: General Application Rates and Timings for Potassium Phosphite

Application Method	Crop Type	Dilution Ratio / Rate	Application Frequency	Reference
Foliar Spray	Fruit Trees	1:1000–1200	2-3 times per growth cycle	[3][17]
Foliar Spray	Vegetables	1:800–1000	Every 10-14 days as required	[3][18]
Foliar Spray (Disease Treatment)	General	1:400–500	As needed	[3]
Soil Drench / Fertigation	General	2.5–4 L per application	As needed	[3]
Turf	Warm and cool season grasses	3-8 oz. per 1,000 sq. ft.	Every 14-21 days	[18]

Experimental Protocols

The following are detailed methodologies for key experiments to evaluate the efficacy of potassium phosphite.

Protocol 1: In Vitro Antifungal Activity Assay

This protocol is designed to assess the direct inhibitory effect of potassium phosphite on the mycelial growth and spore germination of a fungal pathogen.

1. Materials:

- Potassium phosphite stock solution (e.g., 50% w/v)
- Pathogen of interest (e.g., *Colletotrichum lindemuthianum*)
- Potato Dextrose Agar (PDA) medium
- Sterile distilled water
- Sterile Petri dishes (90 mm)
- Micropipettes and sterile tips
- Incubator

- Microscope and hemocytometer
2. Mycelial Growth Inhibition Assay: a. Prepare PDA medium and autoclave. b. While the medium is still molten (around 45-50°C), add potassium phosphite stock solution to achieve the desired final concentrations (e.g., 0, 1, 2.5, 5, 10 mL/L). c. Pour the amended PDA into sterile Petri dishes and allow to solidify. d. Place a 5 mm mycelial plug from the edge of an actively growing culture of the pathogen in the center of each plate. e. Seal the plates and incubate at the optimal temperature for the pathogen (e.g., 25°C). f. Measure the colony diameter daily until the control plate is fully covered. g. Calculate the percentage of mycelial growth inhibition for each concentration.
3. Spore Germination Assay: a. Prepare a spore suspension of the pathogen in sterile distilled water and adjust the concentration to 1×10^6 spores/mL using a hemocytometer. b. Prepare different concentrations of potassium phosphite in sterile distilled water. c. Mix equal volumes of the spore suspension and the potassium phosphite solutions. d. Place a drop of the mixture on a sterile microscope slide, place the slide in a moist chamber, and incubate. e. After a suitable incubation period (e.g., 24 hours), observe at least 100 spores per replicate under a microscope to determine the percentage of germination. f. Calculate the percentage of germination inhibition.

Protocol 2: In Vivo Plant Protection Assay

This protocol evaluates the ability of potassium phosphite to protect plants from disease when applied preventatively.

1. Materials:

- Test plants (e.g., bean or potato seedlings) grown under controlled conditions.
- Potassium phosphite solution at the desired concentration.
- Pathogen inoculum (spore suspension or bacterial culture).
- Spray bottle for foliar application.
- Growth chamber or greenhouse with controlled temperature, humidity, and light.

2. Experimental Procedure: a. Grow healthy, uniform plants to a suitable growth stage (e.g., 3-4 true leaves). b. Divide the plants into treatment groups (e.g., untreated control, water-sprayed control, potassium phosphite-treated). c. Apply the potassium phosphite solution as a foliar spray until runoff. d. After a specified period (e.g., 48-72 hours) to allow for the induction of

plant defenses, inoculate the plants with the pathogen. e. Place the inoculated plants in a high-humidity environment to facilitate infection. f. Assess disease severity at regular intervals using a disease rating scale. g. Calculate the Area Under the Disease Progress Curve (AUDPC) to quantify disease development over time.[13]

Protocol 3: Gene Expression Analysis of Defense-Related Genes

This protocol uses quantitative real-time PCR (qRT-PCR) to measure the expression of defense-related genes in response to potassium phosphite treatment.

1. Materials:

- Plant tissue samples from treated and control plants.
- Liquid nitrogen.
- RNA extraction kit.
- DNase I.
- cDNA synthesis kit.
- qRT-PCR machine and reagents (e.g., SYBR Green).
- Primers for target defense genes (e.g., PR1, PR3, PR4, POD) and a reference gene.[7]

2. Experimental Procedure: a. Collect leaf samples at different time points after potassium phosphite treatment and/or pathogen inoculation. b. Immediately freeze the samples in liquid nitrogen and store at -80°C. c. Extract total RNA from the plant tissue using a suitable kit. d. Treat the RNA with DNase I to remove any contaminating genomic DNA. e. Synthesize first-strand cDNA from the RNA. f. Perform qRT-PCR using the synthesized cDNA, gene-specific primers, and SYBR Green. g. Analyze the gene expression data using the $2^{-\Delta\Delta C_t}$ method, normalizing to the expression of the reference gene.

Mandatory Visualizations

The following diagrams illustrate key concepts related to the action of potassium phosphite.

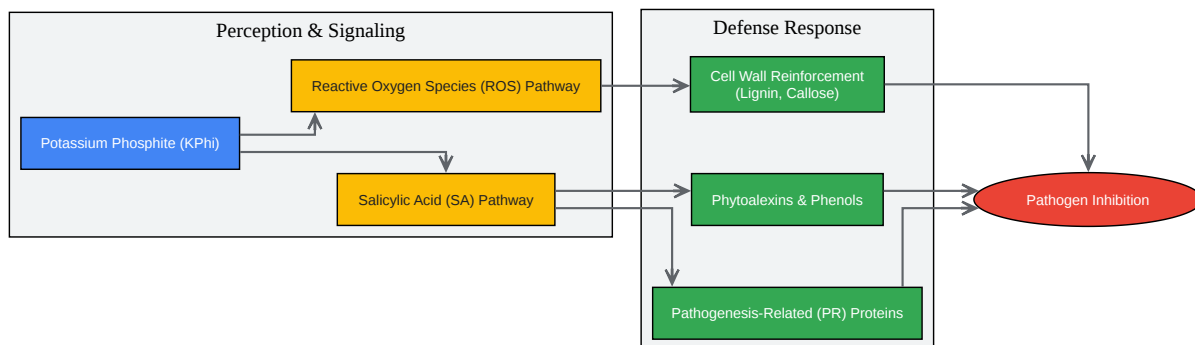

[Click to download full resolution via product page](#)

Caption: Potassium Phosphite Induced Plant Defense Signaling Pathway.

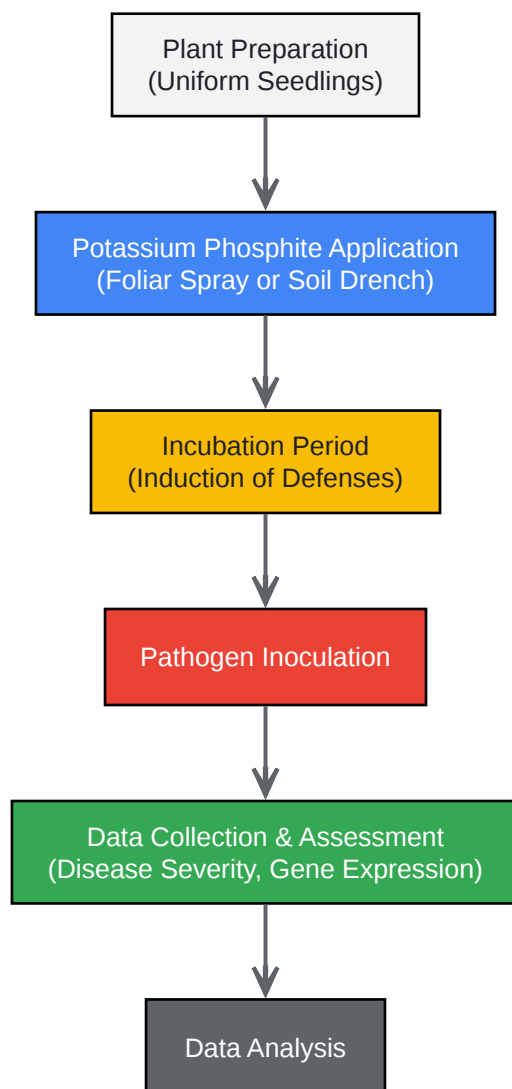

[Click to download full resolution via product page](#)

Caption: General Experimental Workflow for Efficacy Testing.

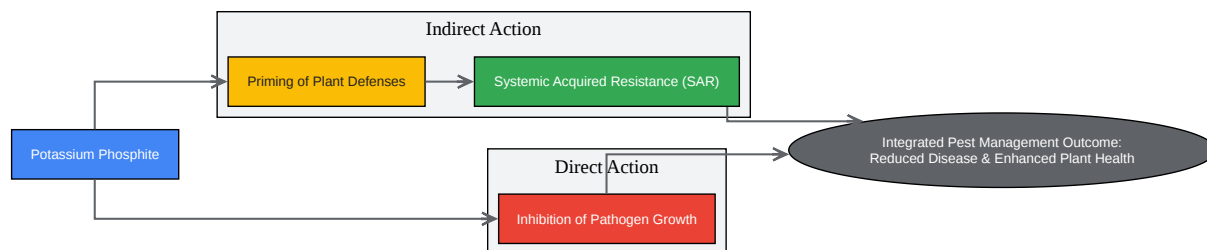

[Click to download full resolution via product page](#)

Need Custom Synthesis?

BenchChem offers custom synthesis for rare earth carbides and specific isotopic labeling.

Email: info@benchchem.com or [Request Quote Online](#).

References

- [1. bartlett.com](http://bartlett.com) [bartlett.com]
- [2. firstsaturdaylime.com](http://firstsaturdaylime.com) [firstsaturdaylime.com]
- [3. wellyoutech.com](http://wellyoutech.com) [wellyoutech.com]
- [4. Potassium Phosphite - how it saves trees](http://chemjet.co.uk) [chemjet.co.uk]
- [5. The Efficacy of Various Preventive Soil-Applied Potassium Phosphite Products Against Foliar Phytophthora Infections on Rhododendron over Time | Arboriculture & Urban Forestry](#) [auf.isa-arbor.com]
- [6. The functional mechanisms of phosphite and its applications in crop plants - PMC](#) [pmc.ncbi.nlm.nih.gov]
- [7. mdpi.com](http://mdpi.com) [mdpi.com]
- [8. Potassium Phosphite Activates Components Associated with Constitutive Defense Responses in Coffea arabica Cultivars - PubMed](#) [pubmed.ncbi.nlm.nih.gov]
- [9. researchgate.net](http://researchgate.net) [researchgate.net]

- [10. Potassium phosphite primes defense responses in potato against Phytophthora infestans - PubMed \[pubmed.ncbi.nlm.nih.gov\]](#)
- [11. Potassium Phosphite's Effects and Functions-nxochem \[nxochem.com\]](#)
- [12. Potassium phosphite: a promising product in the management of diseases caused by Colletotrichum gloeosporioides in coffee plants | Bioscience Journal \[seer.ufu.br\]](#)
- [13. researchgate.net \[researchgate.net\]](#)
- [14. Combination of potassium phosphite and reduced doses of fungicides encourages protection against Phytophthora infestans in potatoes \[biblio.ugent.be\]](#)
- [15. dergipark.org.tr \[dergipark.org.tr\]](#)
- [16. researchgate.net \[researchgate.net\]](#)
- [17. Potassium Phosphite Fertilizer: Systemic Fungicide & Plant Disease Resistance Activator for Crops \[brighthonorfertilizer.com\]](#)
- [18. coastalagro.com \[coastalagro.com\]](#)
- To cite this document: BenchChem. [Application Notes and Protocols for Potassium Phosphite in Integrated Pest Management]. BenchChem, [2026]. [Online PDF]. Available at: [\[https://www.benchchem.com/product/b14129421/docs#application-notes-and-protocols-for-potassium-phosphite-in-integrated-pest-management\]](https://www.benchchem.com/product/b14129421/docs#application-notes-and-protocols-for-potassium-phosphite-in-integrated-pest-management)

Disclaimer & Data Validity:

The information provided in this document is for Research Use Only (RUO) and is strictly not intended for diagnostic or therapeutic procedures. While BenchChem strives to provide accurate protocols, we make no warranties, express or implied, regarding the fitness of this product for every specific experimental setup.

Technical Support: The protocols provided are for reference purposes. Unsure if this reagent suits your experiment?

Need Industrial/Bulk Grade? [Request Custom Synthesis Quote](#)

BenchChem

Our mission is to be the trusted global source of essential and advanced chemicals, empowering scientists and researchers to drive progress in science and industry.

Contact

Address: 3281 E Guasti Rd

Ontario, CA 91761, United States

Phone: (601) 213-4426

Email: info@benchchem.com

[Contact our Ph.D. Support Team for a compatibility check](#)