

A Comparative Guide to the Mass Spectrometry Fragmentation Patterns of N-Aryl Indoles

Author: BenchChem Technical Support Team. **Date:** May 2026

Compound of Interest

Compound Name: *1-(4-methoxyphenyl)-2-phenyl-1H-indole*

CAS No.: 52351-44-7

Cat. No.: B14120134

[Get Quote](#)

For Researchers, Scientists, and Drug Development Professionals

Introduction

N-aryl indoles represent a pivotal scaffold in medicinal chemistry and materials science, forming the core of numerous pharmaceuticals, agrochemicals, and functional organic materials. A profound understanding of their molecular structure is paramount for the development of novel compounds with tailored properties. Mass spectrometry stands as an indispensable tool for the structural elucidation of these molecules. The fragmentation patterns observed in mass spectrometry provide a veritable fingerprint of a molecule, offering deep insights into its connectivity and chemical nature.

This guide provides a comprehensive comparison of the mass spectrometric fragmentation patterns of N-aryl indoles under both Electron Ionization (EI) and Electrospray Ionization (ESI) conditions. Moving beyond a mere catalog of fragments, we will delve into the mechanistic underpinnings of these fragmentation pathways. By understanding the "why" behind the observed cleavages and rearrangements, researchers can more confidently identify unknown

N-aryl indoles, differentiate between isomers, and predict the fragmentation of novel derivatives. This guide is designed to empower researchers to leverage mass spectrometry to its full potential in the study of this important class of compounds.

I. Electron Ionization (EI) Mass Spectrometry: Unraveling the Core Fragmentation

Electron Ionization (EI) is a "hard" ionization technique that imparts significant energy to the analyte molecule, leading to extensive fragmentation. This provides rich structural information, though in some cases, the molecular ion peak may be of low intensity or absent altogether. For N-aryl indoles, EI mass spectra are characterized by several key fragmentation pathways that probe the stability of the indole nucleus and the N-aryl bond.

A. Fundamental Fragmentation of the Indole Nucleus

The indole ring itself possesses a characteristic fragmentation pattern under EI conditions, which often serves as a foundational reference for interpreting the spectra of its derivatives. The primary fragmentation involves the loss of hydrogen cyanide (HCN), a stable neutral molecule, from the pyrrole ring.

Experimental Protocol: Acquiring EI Mass Spectra of N-Aryl Indoles

- **Sample Preparation:** Dissolve the N-aryl indole sample in a volatile organic solvent (e.g., methanol, dichloromethane) to a concentration of approximately 1 mg/mL.
- **Instrumentation:** Utilize a gas chromatograph coupled to a mass spectrometer (GC-MS) equipped with an EI source.
- **GC Conditions:**
 - **Injector Temperature:** 250 °C
 - **Column:** A non-polar capillary column (e.g., DB-5ms, 30 m x 0.25 mm, 0.25 µm film thickness).
 - **Oven Temperature Program:** Start at 100 °C, hold for 1 minute, then ramp to 280 °C at a rate of 15 °C/min, and hold for 5 minutes.

- Carrier Gas: Helium at a constant flow rate of 1 mL/min.
- MS Conditions:
 - Ionization Mode: Electron Ionization (EI)
 - Electron Energy: 70 eV
 - Source Temperature: 230 °C
 - Quadrupole Temperature: 150 °C
 - Scan Range: m/z 40-550
- Data Analysis: Identify the molecular ion peak and major fragment ions. Compare the obtained spectrum with library data where available and propose fragmentation pathways for the observed ions.

B. Fragmentation of N-Phenylindole: A Case Study

N-phenylindole serves as an excellent model to understand the fundamental EI fragmentation of N-aryl indoles. The key fragmentation pathways are initiated by the radical cation formed upon electron impact.

- Molecular Ion ($M^{\bullet+}$): The molecular ion of N-phenylindole is typically observed with high relative abundance, reflecting the stability of the aromatic system.
- Loss of a Hydrogen Atom ($[M-H]^+$): A common fragmentation for aromatic compounds, leading to a stable even-electron cation.
- Cleavage of the N-Phenyl Bond: While direct cleavage to form an indole radical cation and a phenyl cation (or vice-versa) is possible, rearrangements are often more favorable.
- Rearrangement and Fragmentation: A key fragmentation pathway involves a hydrogen rearrangement followed by the expulsion of a stable neutral molecule. For instance, a hydrogen from the phenyl ring can migrate to the indole nitrogen, leading to the formation of a protonated indole-like structure which can then undergo further fragmentation.

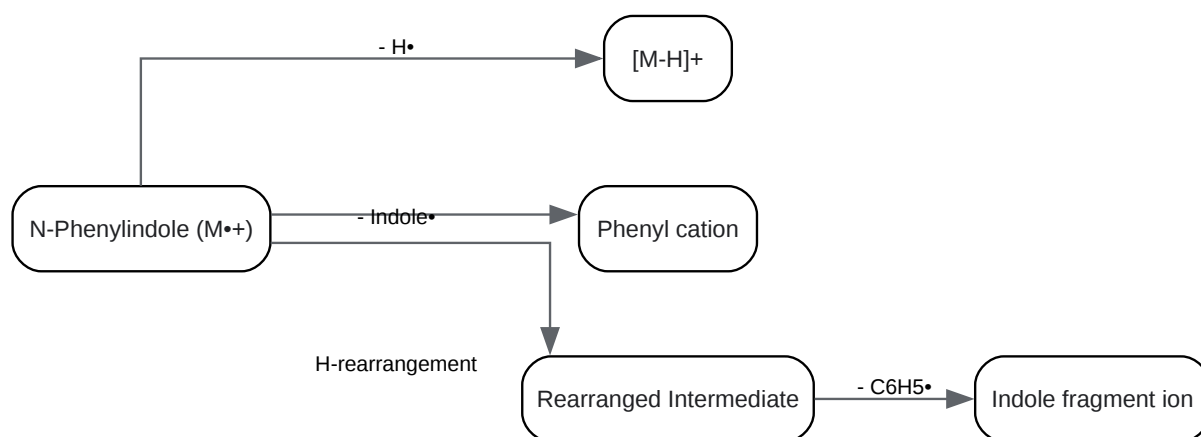

[Click to download full resolution via product page](#)

Figure 1: Simplified EI fragmentation of N-phenylindole.

C. Influence of Substituents on the N-Aryl Ring

The nature and position of substituents on the N-aryl ring significantly influence the fragmentation pattern. Electron-donating groups (EDGs) and electron-withdrawing groups (EWGs) can direct fragmentation pathways by stabilizing or destabilizing key fragment ions.

Substituent on N-Aryl Ring	Effect on Fragmentation	Characteristic Fragment Ions
-CH ₃ (Tolyl)	Promotes benzylic cleavage.	Loss of H• to form a stable tropylium-like ion.
-Cl (Chlorophenyl)	Isotopic pattern of chlorine (³⁵ Cl and ³⁷ Cl in a ~3:1 ratio) is a key diagnostic tool. Cleavage of the C-Cl bond.	[M-Cl] ⁺ , ions showing the characteristic isotopic signature.
-OCH ₃ (Methoxyphenyl)	Favors cleavage of the methyl group, followed by the loss of CO.	[M-CH ₃] ⁺ , [M-CH ₃ -CO] ⁺

The fragmentation of substituted N-aryl-tetrazoles has shown a high dependence on the nature of the substituents, which provides a strong parallel for what is expected with N-aryl indoles.[1]

II. Electrospray Ionization (ESI) Mass Spectrometry: A Softer Approach

Electrospray Ionization (ESI) is a "soft" ionization technique that typically generates protonated molecules ($[M+H]^+$) or other adducts with minimal fragmentation in the ion source. To induce fragmentation and obtain structural information, tandem mass spectrometry (MS/MS) is employed. In ESI-MS/MS, the precursor ion of interest is isolated and then subjected to collision-induced dissociation (CID).

A. Formation of Protonated Molecules and Adducts

In positive-ion ESI, N-aryl indoles readily form protonated molecules ($[M+H]^+$) due to the basicity of the indole nitrogen. The site of protonation can influence the subsequent fragmentation pathways. Theoretical and experimental studies on related N-substituted indoles, such as N-(2-pyridinylmethyl)indoles, have shown that the initial protonation occurs at the most basic site, and subsequent proton transfer can trigger fragmentation.^[2]

Experimental Protocol: Acquiring ESI-MS/MS Spectra of N-Aryl Indoles

- Sample Preparation: Dissolve the N-aryl indole sample in a suitable solvent system (e.g., 50:50 acetonitrile:water with 0.1% formic acid) to a concentration of approximately 10 $\mu\text{g/mL}$.
- Instrumentation: Utilize a liquid chromatograph coupled to a tandem mass spectrometer (LC-MS/MS) equipped with an ESI source.
- LC Conditions:
 - Column: A C18 reversed-phase column (e.g., 100 x 2.1 mm, 2.6 μm particle size).
 - Mobile Phase A: Water with 0.1% formic acid.
 - Mobile Phase B: Acetonitrile with 0.1% formic acid.
 - Gradient: A suitable gradient from 5% to 95% B over several minutes.
 - Flow Rate: 0.3 mL/min.

- MS Conditions:
 - Ionization Mode: Positive Electrospray Ionization (ESI+).
 - Capillary Voltage: 3.5 kV.
 - Source Temperature: 120 °C.
 - Desolvation Temperature: 350 °C.
 - MS1 Scan Range: m/z 100-1000.
- MS/MS Conditions:
 - Select the $[M+H]^+$ ion as the precursor for fragmentation.
 - Collision Gas: Argon.
 - Collision Energy: Optimize for each compound (e.g., ramp from 10-40 eV).
- Data Analysis: Analyze the product ion spectrum to identify characteristic fragment ions and propose fragmentation mechanisms.

B. Key Fragmentation Pathways in ESI-MS/MS

The fragmentation of protonated N-aryl indoles in ESI-MS/MS is often directed by the location of the charge and involves rearrangements and the loss of stable neutral molecules.

- Cleavage of the N-Aryl Bond: This is a prominent fragmentation pathway. The protonated molecule can fragment to produce a protonated indole ion and a neutral aryl radical, or an indole radical and a protonated aryl species. The relative abundance of these fragments will depend on the proton affinity of the indole and aryl moieties.
- Fragmentation of the Indole Ring: Similar to EI, the loss of small molecules like HCN or ethene from the indole ring can occur, although typically requiring higher collision energies.
- Rearrangements involving the Aryl Group: Proton transfer from the indole nitrogen to the aryl ring can initiate fragmentation pathways within the aryl substituent. For example, in N-(p-

methoxyphenyl)indole, a proton transfer could facilitate the loss of formaldehyde.

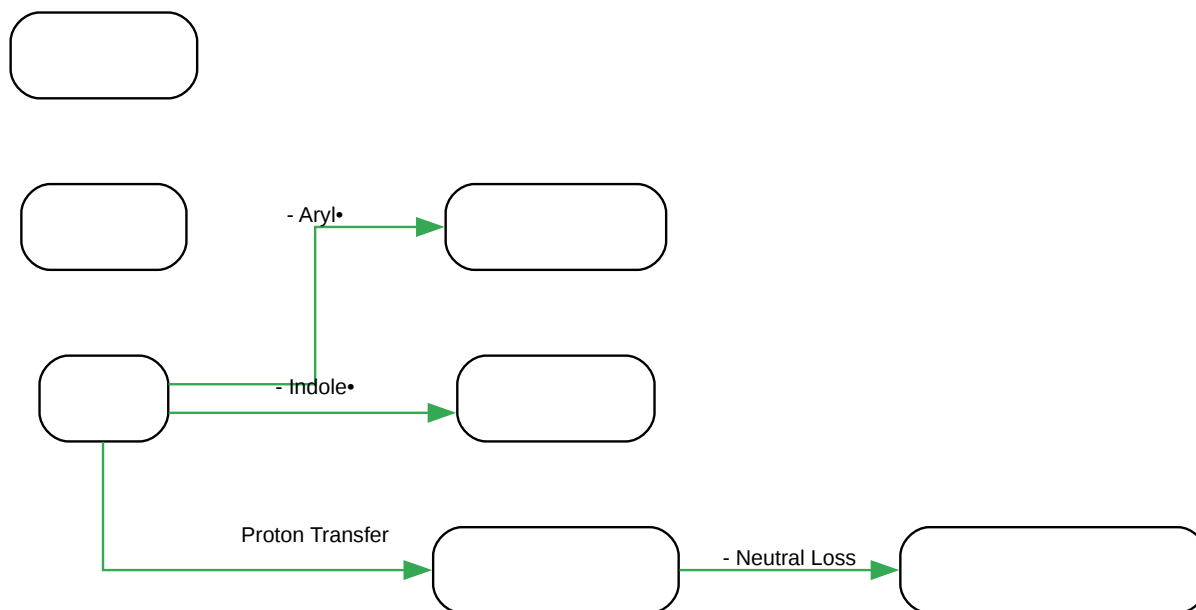

[Click to download full resolution via product page](#)

Figure 2: General ESI-MS/MS fragmentation of N-aryl indoles.

C. Comparative Fragmentation of Substituted N-Aryl Indoles (ESI-MS/MS)

The substituents on the N-aryl ring play a crucial role in directing the ESI-MS/MS fragmentation, often in a more predictable manner than in EI due to the charge-directed nature of the fragmentation.

Substituent on N-Aryl Ring	Expected Fragmentation Behavior	Predicted Major Product Ions
-H (Phenyl)	Cleavage of the N-phenyl bond.	Protonated indole, phenyl cation.
-CH ₃ (Tolyl)	Cleavage of the N-tolyl bond; potential for rearrangement and loss of methane from the protonated tolyl moiety.	Protonated indole, tolyl cation.
-Cl (Chlorophenyl)	Cleavage of the N-chlorophenyl bond; loss of HCl from the protonated chlorophenyl moiety. Isotopic pattern is diagnostic.	Protonated indole, chlorophenyl cation.
-OCH ₃ (Methoxyphenyl)	Cleavage of the N-methoxyphenyl bond; loss of CH ₂ O (formaldehyde) via a proton transfer rearrangement.	Protonated indole, methoxyphenyl cation, [M+H - CH ₂ O] ⁺ .

Studies on related N-aryl compounds have demonstrated that the fragmentation pathways are highly influenced by the electronic effects of the substituents.^[1]

III. Comparison of EI and ESI Fragmentation Patterns

Feature	Electron Ionization (EI)	Electrospray Ionization (ESI-MS/MS)
Ionization	Hard, energetic	Soft, gentle
Molecular Ion	M ^{•+} , often fragmented	[M+H] ⁺ , typically stable
Fragmentation	Extensive, radical-driven	Controlled, charge-driven (CID)
Primary Cleavage	C-H, C-C, and C-N bond cleavages throughout the molecule	Often initiated at the site of protonation; cleavage of the N-aryl bond is common
Rearrangements	Common, can be complex	Often involve proton transfer
Information	Rich structural detail, but can be complex to interpret	Clear precursor-product relationships, good for identifying specific structural motifs

IV. Conclusion and Future Perspectives

The mass spectrometric fragmentation of N-aryl indoles is a rich and informative field of study. Electron Ionization provides a detailed fingerprint of the molecule, with characteristic fragmentation of the indole nucleus and substituent-driven cleavages. Electrospray Ionization coupled with tandem mass spectrometry offers a more controlled fragmentation, often dominated by the cleavage of the N-aryl bond and charge-directed rearrangements.

For researchers in drug development and related fields, a thorough understanding of these fragmentation patterns is crucial for the rapid and accurate identification of novel N-aryl indole derivatives. As new compounds are synthesized, the principles outlined in this guide can be used to predict their fragmentation behavior, aiding in their structural confirmation.

Future work in this area will likely involve the use of high-resolution mass spectrometry to determine the elemental composition of fragment ions with high accuracy, and the application of computational chemistry to model fragmentation pathways and predict mass spectra. The continued development of mass spectrometry techniques and data analysis tools will undoubtedly provide even deeper insights into the gas-phase chemistry of N-aryl indoles.

References

- Nekrasov, Y., et al. (2017). Reactivity of N-Methylidenemalonates of 3-Arylaminoindoles and p-Dimethylamino-N-Phenylaniline in the Course of Their Analysis by Electrospray Ionization Mass Spectrometry. Scientific Research Publishing. [\[Link\]](#)
- Aguiar, G. P. S., et al. (2021). fragmentation of deprotonated plumeran indole alkaloids by electrospray ionization tandem mass spectrometry. Journal of the Brazilian Chemical Society. [\[Link\]](#)
- El Kihel, A., et al. (2016). Study of Mass Spectra of Some Indole Derivatives. American Journal of Analytical Chemistry. [\[Link\]](#)
- Li, Y., et al. (2017). Mass Spectrometric Characteristics of Prenylated Indole Derivatives from Marine-Derived Penicillium sp. NH-SL. Marine Drugs. [\[Link\]](#)
- Sparkman, O. D. (2020). Anatomy of an Ion's Fragmentation After Electron Ionization, Part I. Spectroscopy. [\[Link\]](#)
- LibreTexts. (2021). 4.4: Interpreting Electron Ionization Mass Spectra. Chemistry LibreTexts. [\[Link\]](#)
- Navrátilová, Z., et al. (2024). Synthesis and photodynamic activity of new 5-[(E)-2-(3-alkoxy-1-phenyl-1H-pyrazol-4-yl)ethenyl]. Journal of Heterocyclic Chemistry. [\[Link\]](#)
- Yin, Y., et al. (2012). An experimental and theoretical study on fragmentation of protonated N-(2-pyridinylmethyl)indole in electrospray ionization mass spectrometry. Journal of Mass Spectrometry. [\[Link\]](#)
- Pinga, E., et al. (2023). Different Structures—Similar Effect: Do Substituted 5-(4-Methoxyphenyl). International Journal of Molecular Sciences. [\[Link\]](#)
- University of Arizona. Mass Spectrometry - Interpretation. [\[Link\]](#)
- Chen, Y., et al. (2020). Gas-phase Smiles rearrangement of ortho-nitro-substituted diaryliodonium cations and their mechanistic insights. Rapid Communications in Mass Spectrometry. [\[Link\]](#)

- Jeremić, L. A., et al. (1990). Electron-ionization-induced fragmentation of N-monosubstituted 2-phenylacetamides. *Rapid Communications in Mass Spectrometry*. [[Link](#)]
- Costa, S. P. G., et al. (2021). Substituent Effects on EI-MS Fragmentation Patterns of 5-Allyloxy-1-aryl-tetrazoles and 4-Allyl-1-aryl-tetrazole-5-ones; Correlation with UV-Induced Fragmentation Channels. *Molecules*. [[Link](#)]
- Lee, J. W., et al. (2019). Electrospray ionization-ion mobility spectrometry–high resolution tandem mass spectrometry with collision-induced charge stripping for the analysis of highly multiply charged intact polymers. *Analyst*. [[Link](#)]
- Tsvetkov, Y. E., et al. (2020). Tandem Electrospray Mass Spectrometry of Cyclic N-Substituted Oligo- β -(1 \rightarrow 6)-D-glucosamines. *International Journal of Molecular Sciences*. [[Link](#)]
- Guo, G., et al. (2008). Characteristic fragmentation behavior of 5-[1-aryl- 1H-pyrrol-2-yl]-1H-tetrazole by electrospray ionization tandem mass spectrometry. *Life Science Journal*. [[Link](#)]
- Tan, Y., et al. (2023). Systematic Characterisation of the Fragmentation of Flavonoids Using High-Resolution Accurate Mass Electrospray Tandem Mass Spectrometry. *Metabolites*. [[Link](#)]
- Petreska Stanoeva, J., et al. (2022). ESTABLISHING MASS SPECTRAL FRAGMENTATION PATTERNS FOR THE CHARACTERIZATION OF 1,2-UNSATURATED PYRROLIZIDINE ALKALOIDS AND N-OXIDES IN BORAGINACEAE SPECIES FROM MACEDONIA USING LC-ESI-MS/MS. *Macedonian Journal of Chemistry and Chemical Engineering*. [[Link](#)]
- Davidson, T., et al. (2020). The influence of chemical modifications on the fragmentation behavior of fentanyl and fentanyl-related compounds in electrospray. *Journal of Mass Spectrometry*. [[Link](#)]
- El-Hawary, S. S., et al. (2022). Bioconversion of Callus-Produced Precursors to Silymarin Derivatives in *Silybum marianum* Leaves for the Production of Bioactive Compounds. *Plants*. [[Link](#)]

Need Custom Synthesis?

BenchChem offers custom synthesis for rare earth carbides and specific isotopic labeling.

Email: info@benchchem.com or [Request Quote Online](#).

Sources

- 1. Substituent Effects on EI-MS Fragmentation Patterns of 5-Allyloxy-1-aryl-tetrazoles and 4-Allyl-1-aryl-tetrazole-5-ones; Correlation with UV-Induced Fragmentation Channels - PMC [[pmc.ncbi.nlm.nih.gov](https://pubmed.ncbi.nlm.nih.gov)]
- 2. An experimental and theoretical study on fragmentation of protonated N-(2-pyridinylmethyl)indole in electrospray ionization mass spectrometry - PubMed [pubmed.ncbi.nlm.nih.gov]
- To cite this document: BenchChem. [A Comparative Guide to the Mass Spectrometry Fragmentation Patterns of N-Aryl Indoles]. BenchChem, [2026]. [Online PDF]. Available at: [<https://www.benchchem.com/product/b14120134/docs#a-comparative-guide-to-the-mass-spectrometry-fragmentation-patterns-of-n-aryl-indoles>]

Disclaimer & Data Validity:

The information provided in this document is for Research Use Only (RUO) and is strictly not intended for diagnostic or therapeutic procedures. While BenchChem strives to provide accurate protocols, we make no warranties, express or implied, regarding the fitness of this product for every specific experimental setup.

Technical Support: The protocols provided are for reference purposes. Unsure if this reagent suits your experiment?

Need Industrial/Bulk Grade? [Request Custom Synthesis Quote](#)

BenchChem

Our mission is to be the trusted global source of essential and advanced chemicals, empowering scientists and researchers to drive progress in science and industry.

Contact

Address: 3281 E Guasti Rd

Ontario, CA 91761, United States

Phone: (601) 213-4426

Email: info@benchchem.com

[Contact our Ph.D. Support Team for a compatibility check](#)