

Application Note: Optimization of ZrO₂ Thin Film Deposition using Zr(tmhd)₄

Author: BenchChem Technical Support Team. **Date:** April 2026

Compound of Interest

Compound Name: Zirconium 2,2,6,6-tetramethyl-3,5-heptanedionate

Cat. No.: B14117702

[Get Quote](#)

Achieving High-Crystallinity Tetragonal Phase via MOCVD and High-T ALD

Executive Summary

Zirconium dioxide (ZrO₂) is a critical high- κ dielectric material used in DRAM capacitors, CMOS gate stacks, and optical coatings. While alkylamide precursors (e.g., TEMAZ, TDMAZ) are common for low-temperature Atomic Layer Deposition (ALD), they often suffer from poor thermal stability and premature decomposition.

Zirconium tetrakis(2,2,6,6-tetramethyl-3,5-heptanedionate), denoted as Zr(tmhd)₄ or Zr(thd)₄, offers superior thermal stability, making it the precursor of choice for high-temperature Metal-Organic Chemical Vapor Deposition (MOCVD) and ozone-assisted ALD. This guide defines the optimal deposition temperature window to maximize growth rate while stabilizing the desired tetragonal/cubic phase and minimizing carbon contamination.

The Optimal Temperature Window:

- MOCVD: 500°C – 600°C (Mass Transport Limited Regime)

- Ozone-ALD: 300°C – 400°C (Reaction Limited Regime)

Precursor Chemistry & Properties

Understanding the precursor is the first step to process control. Zr(tmhd)₄ is a

-diketonate complex. Its high thermal stability requires higher activation energy for decomposition compared to amides, necessitating higher deposition temperatures or stronger oxidants (O₃).

Property	Specification	Impact on Process
Formula	Zr(C ₁₁ H ₁₉ O ₂) ₄	High molecular weight (824.3 g/mol) implies lower vapor pressure.
Melting Point	332°C - 339°C	Solid at room temp; requires heated lines/bubblers.
Sublimation	~180°C @ 0.1 Torr	Source temperature must be tightly controlled (typically 180-230°C).
Stability	High (up to ~400°C in inert gas)	Prevents gas-phase pre-reaction; allows excellent step coverage in MOCVD.

Process Optimization: The Temperature Factor MOCVD Growth Regimes (Arrhenius Behavior)

In MOCVD, the deposition rate follows an Arrhenius behavior. For Zr(tmhd)₄, the process is divided into three distinct temperature regimes:

- Kinetic Limited (< 500°C): Surface reaction rates limit growth. Films are often amorphous with high carbon content due to incomplete ligand decomposition.
- Mass Transport Limited (500°C – 650°C): [OPTIMAL WINDOW] Growth rate is constant and limited by the diffusion of precursor to the surface. This regime yields the most uniform thickness and reproducible results.

- Depletion/Desorption ($> 650^{\circ}\text{C}$): Precursor decomposes in the gas phase or desorbs before reacting. Growth rate drops; films may become rough (monoclinic phase dominant).

Crystallinity & Phase Stabilization

- Amorphous: $< 450^{\circ}\text{C}$.^{[1][2][3][4]}
- Tetragonal/Cubic (High- κ): Dominant at $500^{\circ}\text{C} - 600^{\circ}\text{C}$. This is the target phase for dielectric applications ().
- Monoclinic (Low- κ): Begins to nucleate $> 600^{\circ}\text{C}$ or upon post-deposition annealing $> 900^{\circ}\text{C}$.

Visualizing the Process Window

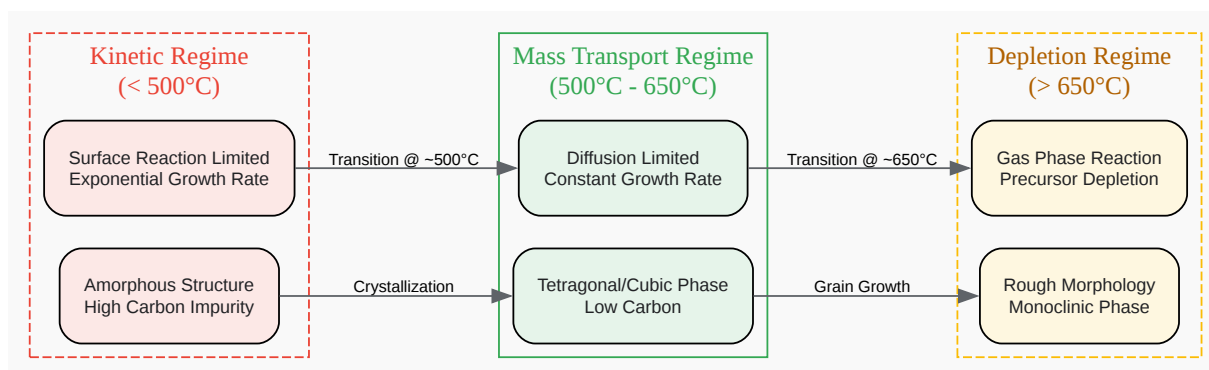

[Click to download full resolution via product page](#)

Figure 1: Arrhenius behavior of ZrO_2 MOCVD growth using $\text{Zr}(\text{tmhd})_4$. The green zone represents the optimal processing window.

Detailed Deposition Protocol (MOCVD)

Objective: Deposit 50 nm Tetragonal ZrO_2 on Si(100).

Equipment Setup

- Reactor: Cold-wall or Hot-wall MOCVD (Low Pressure).
- Precursor Delivery:
 - Option A (Solid Source): Stainless steel bubbler loaded with $\text{Zr}(\text{tmhd})_4$ powder.
 - Option B (Liquid Injection): 0.05 M solution of $\text{Zr}(\text{tmhd})_4$ in solvent (e.g., THF or n-butyl acetate) injected into a vaporizer.

Standard Operating Procedure (SOP)

Step	Parameter	Setpoint / Action	Rationale
1. Substrate Prep	Cleaning	RCA Clean + HF Dip (1%)	Remove native oxide to ensure high-quality interface.
2. Precursor Heat	Temp (Source)	230°C (Bubbler) / 250°C (Vaporizer)	Zr(tmhd) ₄ has low volatility; high T required for sufficient flux.
3. Line Heating	Temp (Lines)	250°C - 260°C	Prevent condensation in delivery lines (Cold spots = particles).
4. Reactor Cond.	Pressure	5 - 10 Torr	Low pressure improves uniformity and reduces gas-phase nucleation.
5. Oxidant Flow	O ₂ Flow	500 - 1000 sccm	Excess oxygen is critical to remove Carbon from the bulky tmhd ligand.
6. Deposition	Substrate Temp	550°C	Optimal Point. Ensures tetragonal phase and mass-transport limited growth.
7. Post-Anneal	Temp / Gas	None (As-deposited is crystalline)	If amorphous (low T dep), anneal at 700°C in O ₂ for 1 min.

Troubleshooting Guide

- Problem: High Carbon Contamination (> 5 at%).
 - Root Cause:[\[5\]](#)[\[6\]](#) Incomplete oxidation of the tmhd ligand.

- Fix: Increase O₂ partial pressure or switch to O₂/O₃ mixture. Increase substrate temperature.
- Problem: Hazy/Rough Film.
 - Root Cause:[5][6] Gas phase pre-reaction (Temperature too high) or parasitic CVD.
 - Fix: Reduce reactor pressure; lower substrate temperature to < 600°C.

Alternative Protocol: Ozone-Assisted ALD

While Zr(tmhd)₄ is less reactive than amides, it enables ALD at temperatures where amides would decompose.

- Oxidant: Ozone (O₃) is mandatory. H₂O is insufficient to remove tmhd ligands at < 400°C.
- Window: 300°C – 400°C.
- Cycle:
 - Pulse Zr(tmhd)₄ (2-5 sec)
 - Purge N₂ (5-10 sec)
 - Pulse O₃ (Concentration > 200 g/Nm³)
 - Purge N₂ (5-10 sec)
- Growth Rate: ~0.3 - 0.5 Å/cycle (Lower than MOCVD, but conformal).

Experimental Workflow Diagram

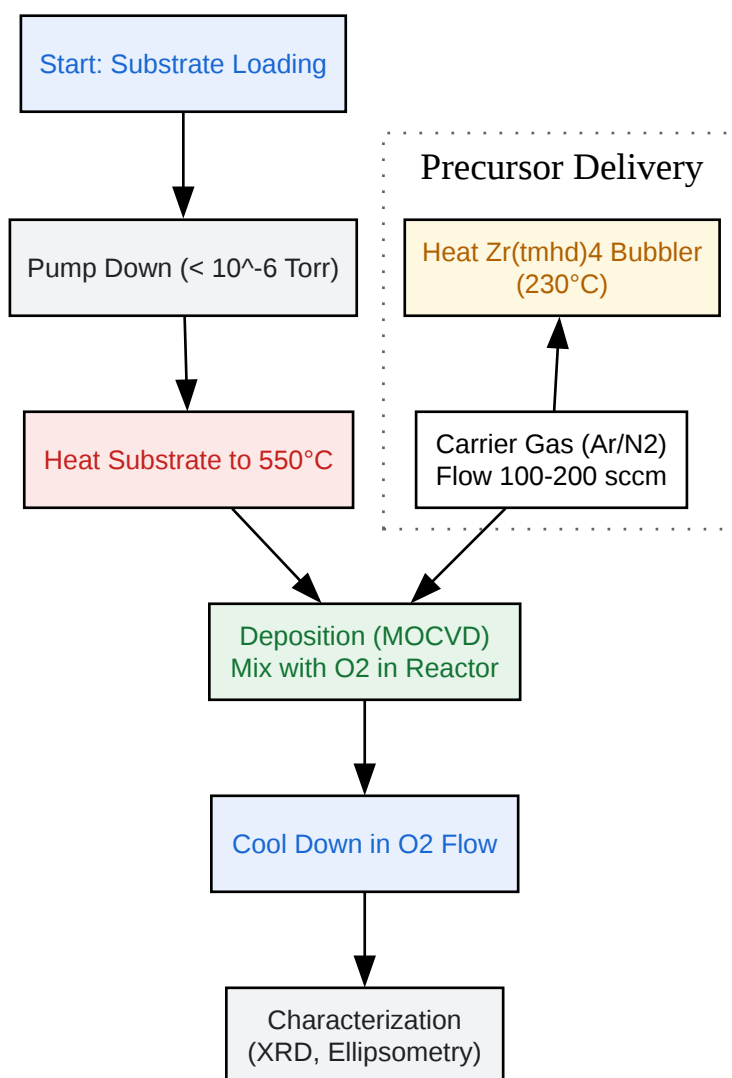

[Click to download full resolution via product page](#)

Figure 2: Step-by-step workflow for ZrO₂ deposition using Zr(tmhd)₄.

References

- Si, J., Desu, S. B., & Tsai, C. Y. (2011). Metal-organic chemical vapor deposition of ZrO₂ films using Zr(thd)₄ as precursors. *Journal of Materials Research*. [Link](#) (Note: Defines the kinetic vs mass transport transition at ~530°C).
- Morozova, N. B., et al. (2012). Thermal study of CVD metal-organic precursors: Zirconium(IV) and yttrium(III) 2,2,6,6-tetramethyl-3,5-heptanedionates. *Journal of Thermal Analysis and Calorimetry*. [Link](#) (Thermal stability data).

- Niinistö, L., et al. (2004). Atomic layer deposition of high-k dielectrics. Materials Science and Engineering: B. [Link](#) (Discusses beta-diketonates vs amides in ALD).
- Sigma-Aldrich.Zirconium tetrakis(2,2,6,6-tetramethyl-3,5-heptanedionate) Product Specification. [Link](#) (Physical properties).

Need Custom Synthesis?

BenchChem offers custom synthesis for rare earth carbides and specific isotopic labeling.

Email: info@benchchem.com or [Request Quote Online](#).

Sources

- 1. chemrxiv.org [chemrxiv.org]
- 2. researchgate.net [researchgate.net]
- 3. Making sure you're not a bot! [helda.helsinki.fi]
- 4. Atomic layer deposition of zirconium oxide thin films | Journal of Materials Research | Cambridge Core [[cambridge.org](https://www.cambridge.org)]
- 5. researchgate.net [researchgate.net]
- 6. Structure and Dielectric Property of High-k ZrO₂ Films Grown by Atomic Layer Deposition Using Tetrakis(Dimethylamido)Zirconium and Ozone - PMC [[pmc.ncbi.nlm.nih.gov](https://pubmed.ncbi.nlm.nih.gov)]
- To cite this document: BenchChem. [Application Note: Optimization of ZrO₂ Thin Film Deposition using Zr(tmhd)₄]. BenchChem, [2026]. [Online PDF]. Available at: [<https://www.benchchem.com/product/b14117702/docs#application-note-optimization-of-zro-thin-film-deposition-using-zr-tmhd>]

Disclaimer & Data Validity:

The information provided in this document is for Research Use Only (RUO) and is strictly not intended for diagnostic or therapeutic procedures. While BenchChem strives to provide accurate protocols, we make no warranties, express or implied, regarding the fitness of this product for every specific experimental setup.

Technical Support: The protocols provided are for reference purposes. Unsure if this reagent suits your experiment?

Need Industrial/Bulk Grade? [Request Custom Synthesis Quote](#)

BenchChem

Our mission is to be the trusted global source of essential and advanced chemicals, empowering scientists and researchers to drive progress in science and industry.

Contact

Address: 3281 E Guasti Rd
Ontario, CA 91761, United States
Phone: (601) 213-4426
Email: info@benchchem.com

[Contact our Ph.D. Support Team for a compatibility check](#)