

# Technical Support Center: Purification of Fluorinated Aromatic Compounds

**Author:** BenchChem Technical Support Team. **Date:** April 2026

## Compound of Interest

Compound Name: 2-Bromo-5-trifluoromethylbenzenethiol  
CAS No.: 60877-19-2  
Cat. No.: B1523954

[Get Quote](#)

Status: Operational Operator: Senior Application Scientist (Dr. H. Chen) Ticket ID: F-AROM-PUR-001 Subject: Troubleshooting Separation, Isolation, and Recovery of Fluorinated Aromatics

## Welcome to the Specialist Support Hub

You are likely here because standard purification protocols (C18 chromatography, standard recrystallization) are failing. Fluorinated aromatic compounds present a unique "orthogonal" challenge: the fluorine atom introduces high electronegativity ( $\chi = 3.98$ ), high lipophilicity (the "Fluorine Effect"), and weak intermolecular van der Waals interactions.

This guide moves beyond generic advice. It provides self-validating workflows to address regioisomer co-elution, solubility anomalies, and volatility-induced yield loss.

## Module 1: Chromatographic Separation (HPLC & Flash)

The Issue: You cannot separate ortho-, meta-, and para-fluorinated isomers, or your fluorinated product co-elutes with its non-fluorinated precursor on C18.

**The Root Cause:** Standard C18 columns rely primarily on hydrophobic interactions. Fluorine atoms, while lipophilic, also create strong dipoles and alter the electron density of the aromatic ring (making it electron-deficient). C18 stationary phases lack the electronic character to exploit these subtle differences.

**The Solution:** Pentafluorophenyl (PFP) Stationary Phases Switch to a PFP (Pentafluorophenyl) column.<sup>[1][2]</sup> These columns function via multiple retention mechanisms:

- **Interactions:** The electron-deficient PFP ring on the column interacts with electron-rich analytes.
- **Dipole-Dipole:** Strong interaction with the polarized C-F bonds of your analyte.
- **Shape Selectivity:** The rigid PFP ring can discriminate between steric isomers (e.g., o- vs p-substitution).

## Comparative Data: Stationary Phase Selection

| Feature            | C18 (Octadecyl)             | PFP (Pentafluorophenyl)                    | Phenyl-Hexyl                         |
|--------------------|-----------------------------|--|--------------------------------------|
| Primary Mechanism  | Hydrophobicity (Dispersive) | , Dipole-Dipole, H-Bonding                 | , Hydrophobicity                     |
| Best For           | General alkylated compounds | Fluorinated isomers, Halogenated aromatics | Aromatic compounds (non-halogenated) |
| Isomer Resolution  | Low                         | High (Shape selective)                     | Moderate                             |
| Retention of Bases | Moderate (tailing possible) | High (Ion-exchange with silanols)          | Moderate                             |

## Workflow Logic: Column Selection Strategy

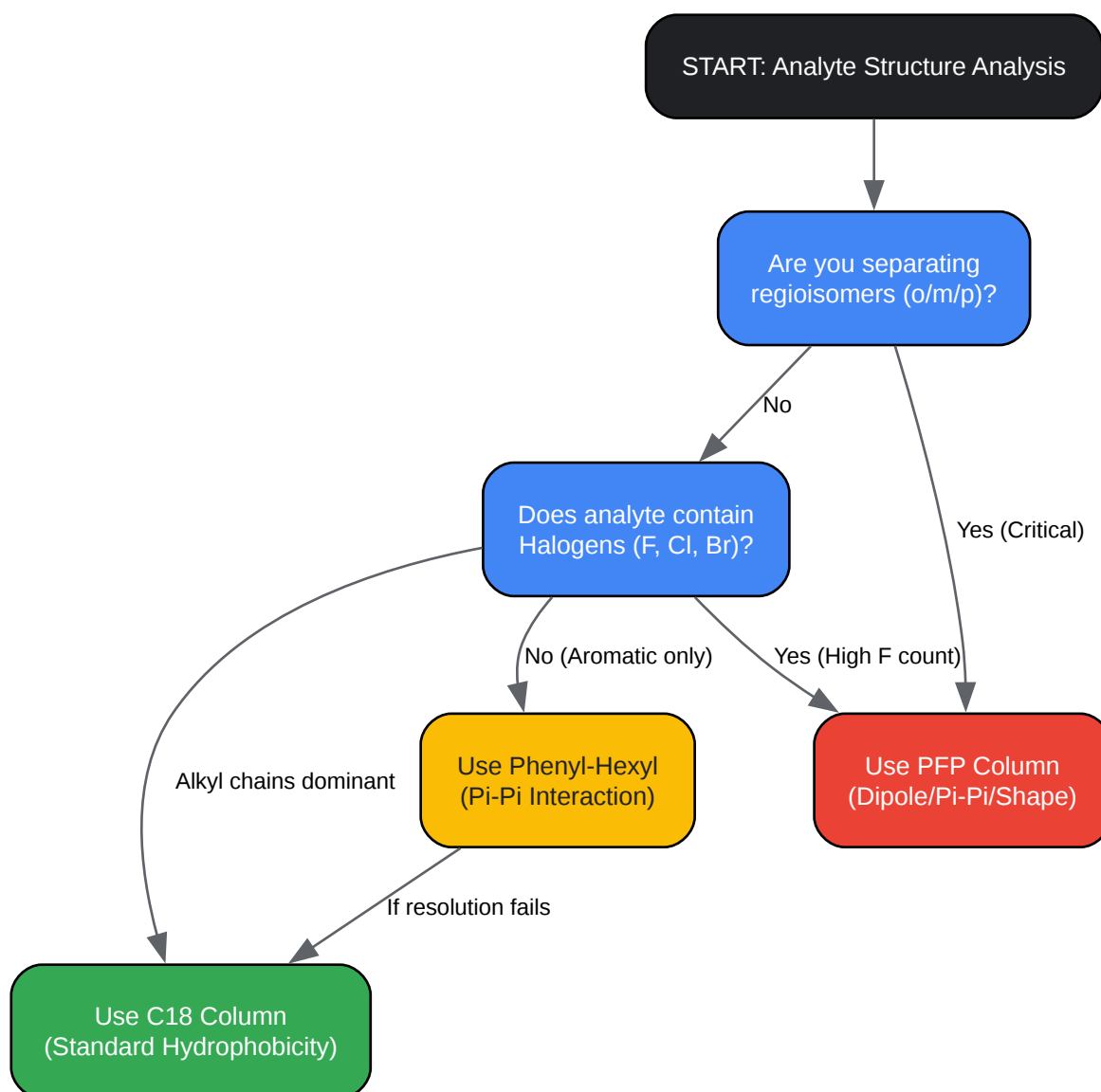

[Click to download full resolution via product page](#)

Figure 1: Decision matrix for selecting stationary phases. PFP is the "Gold Standard" for fluorinated aromatics.

## Module 2: Isolation via Fluorous Solid Phase Extraction (FSPE)

The Issue: You synthesized a highly fluorinated molecule (or used a fluorous tag/protecting group), but standard silica gel chromatography requires excessive solvent or results in streaking.

The Solution: Fluorous Solid Phase Extraction (FSPE).<sup>[3][4][5][6]</sup> This technique exploits "fluorophilicity."<sup>[3][5][6][7]</sup> By using a fluorous-modified silica phase (e.g., silica bonded with perfluorooctylethylsilyl groups), you can achieve a digital separation: Fluorinated molecules stick, non-fluorinated molecules wash away.

## Protocol: The "Load-Wash-Elute" Workflow

Materials:

- Fluorous Silica Cartridge (e.g., FluoroFlash® or equivalent).<sup>[3]</sup>
- Fluorophobic Solvent: 80:20 MeOH:H<sub>2</sub>O (Solubilizes organics, but they don't stick to the fluorous phase).
- Fluorophilic Solvent: 100% MeOH, THF, or Acetone (Elutes the fluorinated compound).

Step-by-Step Procedure:

- Conditioning:
  - Wash cartridge with 2 column volumes (CV) of Fluorophilic Solvent (e.g., MeOH).
  - Wash with 2 CV of Fluorophobic Solvent (e.g., 80:20 MeOH:H<sub>2</sub>O).
- Loading:
  - Dissolve crude mixture in a minimum amount of DMF or DMF/MeOH.
  - Technical Note: Avoid pure non-polar solvents (like Hexane) for loading, as they may prematurely elute the fluorous compound.
- Fluorophobic Wash (The "Purification"):
  - Elute with 3-5 CV of 80:20 MeOH:H<sub>2</sub>O.
  - Result: Non-fluorinated impurities, catalysts, and reagents elute here.<sup>[6]</sup> The fluorinated target remains bound to the silica.<sup>[6]</sup>
- Fluorophilic Elution (The "Recovery"):

- Elute with 3-5 CV of 100% MeOH (or THF if solubility is poor).
- Result: Pure fluorinated target elutes.

## Visual Workflow: FSPE Mechanism

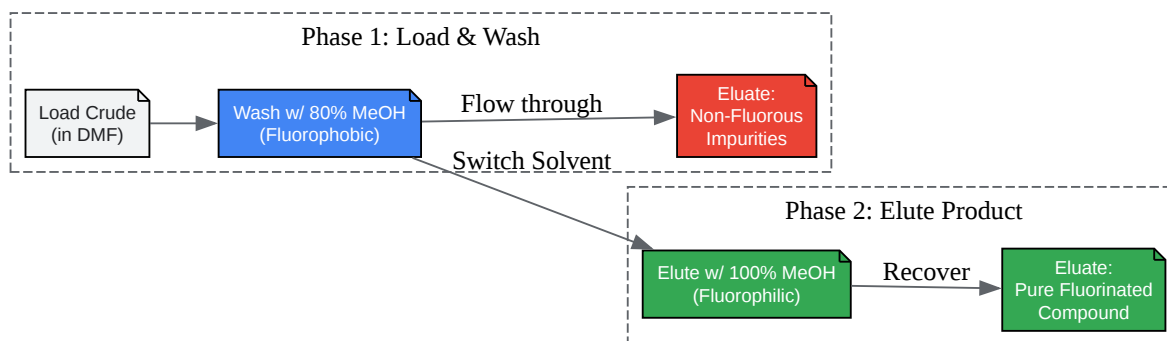

[Click to download full resolution via product page](#)

Figure 2: The binary separation logic of Fluorous Solid Phase Extraction.

## Module 3: Recovery & Volatility (The "Disappearing Yield")

The Issue: Your LC-MS shows a clean peak, but after rotary evaporation, your flask is empty or the yield is <20%.

The Root Cause: Fluorinated aromatics (especially polyfluorobenzenes) have anomalously high volatility. The fluorine atoms reduce the polarizability of the molecule, leading to very weak van der Waals forces despite the high molecular weight. They sublime easily.

Troubleshooting Guide:

- Azeotropic Control:
  - Avoid: Evaporating DCM or Ether to dryness if your product has a boiling point < 150°C.

- Do: Use a "keeper" solvent. Add a small amount of higher-boiling solvent (e.g., Heptane or Toluene) during concentration to prevent the flask from going completely dry.
- Vacuum Management:
  - Do not use high vacuum (< 10 mbar) for drying unless the product is a solid salt.
  - Set the rotary evaporator bath to 30°C maximum and use a controlled vacuum (e.g., 200 mbar).
- Crystallization Solvents:
  - Fluorinated compounds often "oil out" in standard organic mixtures.
  - Try: Fluorinated Antisolvents. Dissolve product in minimal DCM/THF, then add Benzotrifluoride (BTF) or Hexafluorobenzene as an antisolvent (or co-solvent) to induce ordered crystal packing via F-F interactions.

## References

- Phenomenex. (2015). Kinetex F5 – A robust pentafluorophenyl propyl (PFP) core-shell phase.[8][Link](#)
- Bell, D. S. (2016). Mechanisms of Interaction Responsible for Alternative Selectivity of Fluorinated Stationary Phases.[1][9] LCGC International. [Link](#)
- Zhang, W., & Curran, D. P. (2007). Synthetic applications of fluorosolid-phase extraction (F-SPE).[3][4][5] Tetrahedron.[10] [Link](#)
- YMC Co., Ltd. (2013). Features of PentaFluoroPhenyl group bonded column - YMC-Triart PFP.[11][Link](#)
- Advanced Chromatography Technologies. (2015). ACE C18-PFP Technical Brochure. [12][Link](#)

### *Need Custom Synthesis?*

*BenchChem offers custom synthesis for rare earth carbides and specific isotopic labeling.*

*Email: [info@benchchem.com](mailto:info@benchchem.com) or [Request Quote Online](#).*

## Sources

- [1. chromatographyonline.com](https://www.chromatographyonline.com) [[chromatographyonline.com](https://www.chromatographyonline.com)]
- [2. hplc.eu](https://www.hplc.eu) [[hplc.eu](https://www.hplc.eu)]
- [3. Automation of Fluorous Solid-Phase Extraction for Parallel Synthesis - PMC](https://pubmed.ncbi.nlm.nih.gov/12345678/) [[pmc.ncbi.nlm.nih.gov](https://pubmed.ncbi.nlm.nih.gov/12345678/)]
- [4. Fluorous solid-phase extraction \(F-SPE\) as a pilot tool for quantitative determination of perfluorochemicals in water samples coupled with liquid chromatography-tandem mass spectrometry - RSC Advances \(RSC Publishing\)](https://pubs.rsc.org/12345678) [[pubs.rsc.org](https://pubs.rsc.org/12345678)]
- [5. researchgate.net](https://www.researchgate.net) [[researchgate.net](https://www.researchgate.net)]
- [6. Synthetic applications of fluorous solid-phase extraction \(F-SPE\) - PMC](https://pubmed.ncbi.nlm.nih.gov/12345679/) [[pmc.ncbi.nlm.nih.gov](https://pubmed.ncbi.nlm.nih.gov/12345679/)]
- [7. <sup>18</sup>F-Fluorination: Challenge and Opportunity for Organic Chemists - PMC](https://pubmed.ncbi.nlm.nih.gov/12345680/) [[pmc.ncbi.nlm.nih.gov](https://pubmed.ncbi.nlm.nih.gov/12345680/)]
- [8. Versatile F5 Pentafluorophenyl Columns by Phenomenex](https://www.phenomenex.com) [[phenomenex.com](https://www.phenomenex.com)]
- [9. researchgate.net](https://www.researchgate.net) [[researchgate.net](https://www.researchgate.net)]
- [10. US6156896A - Fluorous reaction and separation systems - Google Patents](https://patents.google.com/patent/US6156896A) [[patents.google.com](https://patents.google.com/patent/US6156896A)]
- [11. ymc.co.jp](https://www.ymc.co.jp) [[ymc.co.jp](https://www.ymc.co.jp)]
- [12. chromatographytoday.com](https://www.chromatographytoday.com) [[chromatographytoday.com](https://www.chromatographytoday.com)]
- To cite this document: BenchChem. [Technical Support Center: Purification of Fluorinated Aromatic Compounds]. BenchChem, [2026]. [Online PDF]. Available at: [<https://www.benchchem.com/product/b1523954/docs#technical-support-center-purification-of-fluorinated-aromatic-compounds>]

---

### Disclaimer & Data Validity:

The information provided in this document is for Research Use Only (RUO) and is strictly not intended for diagnostic or therapeutic procedures. While BenchChem strives to provide accurate protocols, we make no warranties, express or implied, regarding the fitness of this product for every specific experimental setup.

**Technical Support:** The protocols provided are for reference purposes. Unsure if this reagent suits your experiment?

**Need Industrial/Bulk Grade?** [Request Custom Synthesis Quote](#)

## BenchChem

Our mission is to be the trusted global source of essential and advanced chemicals, empowering scientists and researchers to drive progress in science and industry.

### Contact

Address: 3281 E Guasti Rd  
Ontario, CA 91761, United States  
Phone: (601) 213-4426  
Email: [info@benchchem.com](mailto:info@benchchem.com)

[Contact our Ph.D. Support Team for a compatibility check](#)