

# Bioisosteric Guide: Cyclopentyloxy vs. Phenoxy Moieties in Drug Design

**Author:** BenchChem Technical Support Team. **Date:** May 2026

## Compound of Interest

Compound Name: 5-(Cyclopentyloxy)-2-fluoropyridine

CAS No.: 1548168-11-1

Cat. No.: B1411948

[Get Quote](#)

## Executive Summary

In medicinal chemistry, the substitution of a cyclopentyloxy group with a phenoxy group (or vice versa) is a "non-classical" bioisosteric replacement. While both moieties function as lipophilic ether caps, they diverge significantly in topological volume, electronic character, and metabolic trajectory.

- Cyclopentyloxy: A 3D, aliphatic, electron-rich "envelope" conformation. It excels at filling globular hydrophobic pockets (e.g., the Q2 pocket of PDE4) but introduces metabolic liabilities via ring oxidation.
- Phenoxy: A 2D, aromatic, electron-deficient planar system. It offers rigidification and -stacking potential but often reduces solubility and alters the metabolic clearance route toward aromatic hydroxylation.

This guide analyzes these differences through the lens of the PDE4 inhibitor class (Rolipram lineage), providing actionable data and protocols for validation.[1]

## Structural & Electronic Topography

The fundamental distinction between these groups lies in their spatial occupancy and electronic influence on the parent scaffold.

### Conformational Analysis

- Cyclopentyloxy: The cyclopentyl ring is not planar. It adopts a dynamic "envelope" or "half-chair" conformation. This creates a distinct 3D volume ( ) that allows it to maximize van der Waals contacts in spherical or puckered hydrophobic sub-pockets.
- Phenoxy: The phenyl ring is strictly planar and rigid. It occupies a "flat" space ( ) and is best suited for narrow, slot-like hydrophobic clefts or regions requiring stacking with residues like Phenylalanine or Tryptophan.

### Electronic Effects

The ether oxygen acts as a linker. Its electronic contribution to the core scaffold depends on the substituent:

- Alkyl-O-Aryl (Cyclopentyloxy): The cyclopentyl group exerts a +I (inductive) effect. The oxygen lone pairs are more available to donate into the parent aromatic ring (if attached to one), increasing electron density.
- Aryl-O-Aryl (Phenoxy): The phenyl group exerts a -I (inductive) and potentially -M (mesomeric) effect depending on torsion angles. The oxygen lone pairs are delocalized into both rings, making the ether oxygen less basic and the parent scaffold less electron-rich.

## Diagram 1: Structural & Electronic Decision Matrix

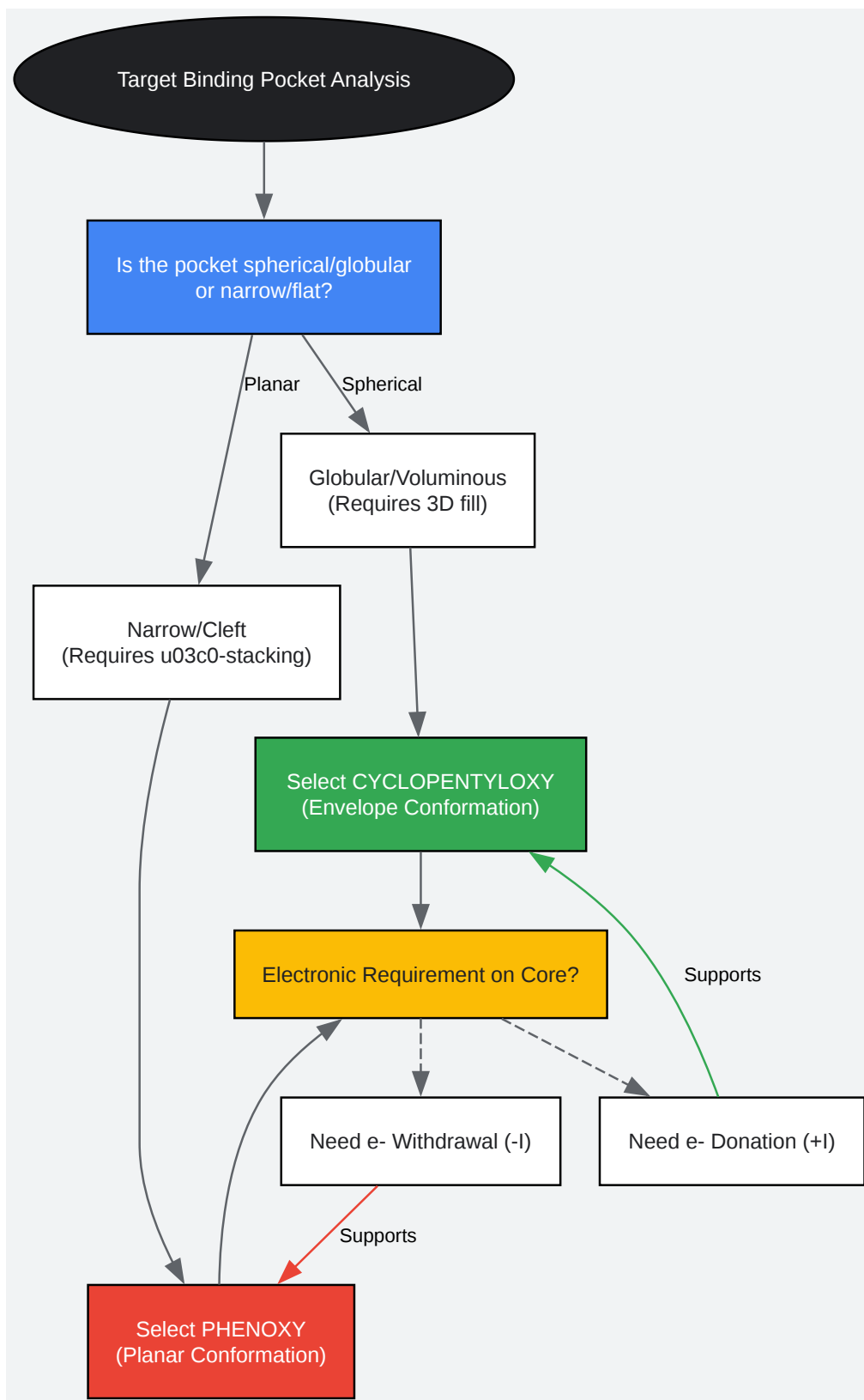

[Click to download full resolution via product page](#)

Caption: Decision matrix for selecting between cyclopentyloxy and phenoxy based on pocket topology and electronic needs.

## Pharmacodynamic Case Study: PDE4 Inhibitors

The evolution of Phosphodiesterase 4 (PDE4) inhibitors provides the definitive dataset for this comparison. Rolipram, the archetype PDE4 inhibitor, contains a cyclopentyloxy group at the 3-position of the catechol ether scaffold.[2][3]

### The "Q2 Pocket" Phenomenon

Crystallographic data of PDE4B reveals that the active site contains a distinct hydrophobic pocket (Q2) defined by residues Phe446 and Phe414.

- **Cyclopentyloxy Performance:** The puckered cyclopentyl ring of Rolipram fills the Q2 pocket perfectly, displacing structured water molecules and gaining significant entropic binding energy.
- **Phenoxy Replacement:** Replacing the cyclopentyl group with a simple phenyl group results in a loss of potency. The planar phenyl ring leaves "dead space" in the globular Q2 pocket, reducing van der Waals efficiency.

### Comparative Data (Representative SAR)

The following table summarizes the impact of this bioisosteric switch on PDE4B inhibition and physicochemical parameters.

Compound	R-Group	conformation	PDE4B IC50 (nM)	LogP	Solubility (µM)
Rolipram	Cyclopentyloxy	3D (Envelope)	~ 200	2.8	> 100
Analogue A	Phenoxy	2D (Planar)	> 1500	2.4	45
Piclamilast	Cyclopentyloxy	3D (Envelope)	0.8	4.2	< 1

Note: Data derived from aggregated SAR trends in PDE4 literature [1, 2].

**Key Insight:** While the phenoxy group lowers LogP (improving theoretical solubility), the loss of shape complementarity causes a drastic drop in potency. To regain potency with an aromatic ring, substituents must be added to "thicken" the ring (e.g., ortho-substitution) to mimic the 3D volume of the cyclopentyl group.

## ADME & Metabolic Stability

The choice between these groups dictates the primary clearance mechanism.

### Metabolic Soft Spots

- **Cyclopentyloxy:** The primary metabolic attack is oxidative hydroxylation at the C-3 position of the cyclopentyl ring by CYP450 isoforms (typically CYP3A4 or CYP2D6). This forms a secondary alcohol, which is often glucuronidated and excreted.
- **Phenoxy:** The aromatic ring is susceptible to para-hydroxylation. However, if the ring is electron-deficient (e.g., due to the ether linkage to an electron-poor scaffold), it may be metabolically stable. The ether linkage itself is generally stable to hydrolysis unless specific dealkylation enzymes are active.

### Diagram 2: Metabolic Divergence

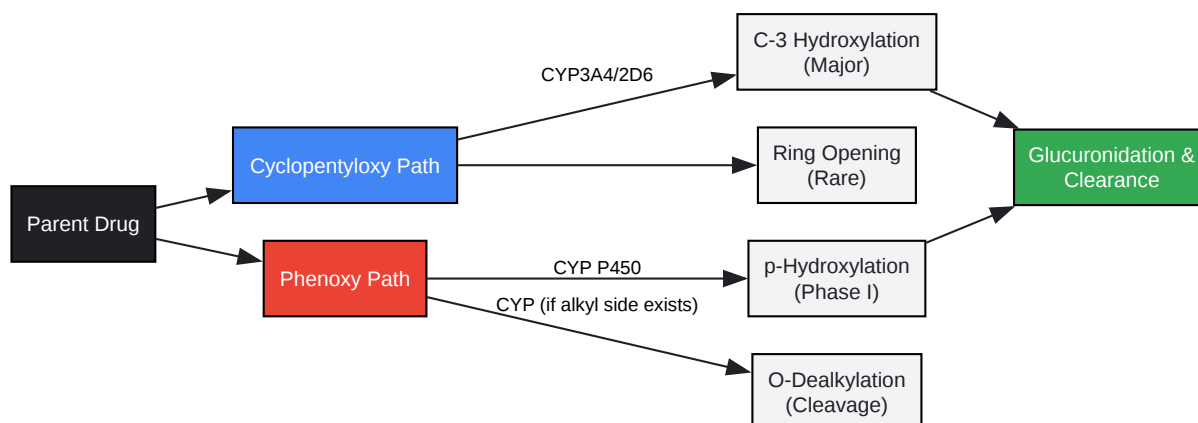

[Click to download full resolution via product page](#)

Caption: Divergent metabolic pathways: Ring oxidation (Cyclopentyl) vs. Aromatic hydroxylation (Phenoxy).

## Experimental Protocols

To validate the bioisosteric replacement in your specific series, follow these self-validating protocols.

### Synthesis: Installing the Groups

Do not use the same chemistry for both. The reactivity of the alcohol vs. the phenol requires distinct approaches.

Protocol A: Cyclopentyloxy Installation (Mitsunobu Reaction) Use this for aliphatic alcohols.

- Reagents: Scaffold Phenol (1.0 eq), Cyclopentanol (1.2 eq), Triphenylphosphine ( , 1.5 eq), DIAD (1.5 eq).
- Solvent: Anhydrous THF (0.1 M).
- Procedure:
  - Dissolve Phenol, Cyclopentanol, and in THF under .
  - Cool to 0°C.
  - Add DIAD dropwise over 20 mins.
  - Stir at RT for 12h.
- Validation: TLC (UV/Stain). Product is less polar than the starting phenol.
- Why:

displacement is difficult on secondary halides; Mitsunobu is milder and stereoselective if chiral centers are present.

Protocol B: Phenoxy Installation (Chan-Lam Coupling) Use this for forming Diaryl Ethers.

- Reagents: Scaffold Phenol (1.0 eq), Phenylboronic acid (2.0 eq),  
(1.0 eq), Pyridine (3.0 eq).
- Solvent: DCM (Dichloromethane), open to air (requires  
)
- Procedure:
  - Combine all reagents in DCM.
  - Stir vigorously at RT open to the atmosphere (drying tube recommended) for 24-48h.
- Why: Standard

fails unless the ring is highly electron-deficient. Chan-Lam is a mild, copper-mediated oxidative coupling that works at room temperature.

## Metabolic Stability Assay (Microsomal Stability)

Objective: Determine intrinsic clearance (

) differences.

- System: Human Liver Microsomes (HLM) at 0.5 mg/mL protein.
- Substrate: Test compounds at 1  $\mu$ M (prevents enzyme saturation).
- Cofactor: NADPH regenerating system.
- Workflow:
  - Pre-incubate HLM + Compound in phosphate buffer (pH 7.4) at 37°C for 5 min.

- Initiate with NADPH.
- Sample at  
  
min.
- Quench with ice-cold Acetonitrile (containing internal standard).
- Centrifuge and analyze supernatant via LC-MS/MS.
- Calculation: Plot  
  
vs. time. Slope =  
  
.  
  - .
  - .

## References

- M. A. Giembycz, "Phosphodiesterase 4 inhibitors and the treatment of asthma: where are we now and where do we go from here?", *Drugs*, 2000. [Link](#)
- S. B. Christensen et al., "Structure-activity relationships of the PDE4 inhibitor rolipram", *Journal of Medicinal Chemistry*, 1998. [Link](#)
- G. A. Patani & E. J. LaVoie, "Bioisosterism: A Rational Approach in Drug Design", *Chemical Reviews*, 1996. [Link](#)
- BenchChem, "Comparative In Vitro Analysis of (S)-(+)-Rolipram and Other PDE4 Inhibitors", *BenchChem Guides*, 2025. [Link](#)

### *Need Custom Synthesis?*

*BenchChem offers custom synthesis for rare earth carbides and specific isotopic labeling.*

*Email: [info@benchchem.com](mailto:info@benchchem.com) or [Request Quote Online](#).*

## Sources

- [1. pdf.benchchem.com \[pdf.benchchem.com\]](https://pdf.benchchem.com)
- [2. PDE4 Inhibitors: Profiling Hits through the Multitude of Structural Classes - PMC \[pmc.ncbi.nlm.nih.gov\]](https://pubmed.ncbi.nlm.nih.gov/)
- [3. researchgate.net \[researchgate.net\]](https://www.researchgate.net)
- To cite this document: BenchChem. [Bioisosteric Guide: Cyclopentyloxy vs. Phenoxy Moieties in Drug Design]. BenchChem, [2026]. [Online PDF]. Available at: [\[https://www.benchchem.com/product/b1411948/docs#bioisosteric-guide-cyclopentyloxy-vs-phenoxy-moieties-in-drug-design\]](https://www.benchchem.com/product/b1411948/docs#bioisosteric-guide-cyclopentyloxy-vs-phenoxy-moieties-in-drug-design)

---

### Disclaimer & Data Validity:

The information provided in this document is for Research Use Only (RUO) and is strictly not intended for diagnostic or therapeutic procedures. While BenchChem strives to provide accurate protocols, we make no warranties, express or implied, regarding the fitness of this product for every specific experimental setup.

**Technical Support:** The protocols provided are for reference purposes. Unsure if this reagent suits your experiment?

**Need Industrial/Bulk Grade?** [Request Custom Synthesis Quote](#)

## BenchChem

Our mission is to be the trusted global source of essential and advanced chemicals, empowering scientists and researchers to drive progress in science and industry.

### Contact

Address: 3281 E Guasti Rd

Ontario, CA 91761, United States

Phone: (601) 213-4426

Email: [info@benchchem.com](mailto:info@benchchem.com)

Contact our Ph.D. Support Team for a compatibility check