

# Section 1: Foundational Principles and Strategic Approach

**Author:** BenchChem Technical Support Team. **Date:** April 2026

## Compound of Interest

Compound Name: 3,4-Dichloro-5-fluorobenzamide

CAS No.: 1803834-98-1

Cat. No.: B1410052

[Get Quote](#)

The structural confirmation of a polysubstituted aromatic ring like that in **3,4-Dichloro-5-fluorobenzamide** presents a unique analytical challenge. The presence of multiple halogens (Cl, F) and an amide group significantly influences the electronic environment of each nucleus. NMR spectroscopy is the premier analytical technique for this task due to its ability to probe the precise chemical environment of individual atoms.

- <sup>1</sup>H NMR Spectroscopy: Provides information on the number and connectivity of protons. In this molecule, the two aromatic protons and the two amide protons are the key reporters. Their chemical shifts ( $\delta$ ), splitting patterns (multiplicity), and coupling constants (J) reveal through-bond proximity to other nuclei.
- <sup>13</sup>C NMR Spectroscopy: Reveals the carbon skeleton of the molecule. Each unique carbon atom gives a distinct signal, and its chemical shift is indicative of its hybridization and bonding environment (e.g., C=O, C-Cl, C-F).
- <sup>19</sup>F NMR Spectroscopy: Fluorine-19 is an exceptional NMR probe due to its 100% natural abundance, high sensitivity (83% of <sup>1</sup>H), and a wide chemical shift range that is exquisitely sensitive to the local electronic environment.<sup>[1][2][3]</sup> This makes <sup>19</sup>F NMR a powerful tool for

confirming the presence and substitution pattern of fluorine-containing compounds, as there are no background signals in typical biological or organic systems.[4]

- 2D NMR Spectroscopy (COSY & HSQC): While 1D spectra provide foundational data, 2D experiments are essential for unambiguous assignments.
  - COSY (Correlation Spectroscopy) maps  $^1\text{H}$ - $^1\text{H}$  J-coupling correlations, definitively establishing which protons are adjacent in the spin system.[5][6]
  - HSQC (Heteronuclear Single Quantum Coherence) correlates directly bonded  $^1\text{H}$ - $^{13}\text{C}$  pairs, providing an unbreakable link between the proton and carbon frameworks.[5][7][8]

Our strategic workflow, therefore, begins with acquiring high-quality 1D spectra of all relevant nuclei, followed by 2D correlation experiments to assemble the structural puzzle with confidence.

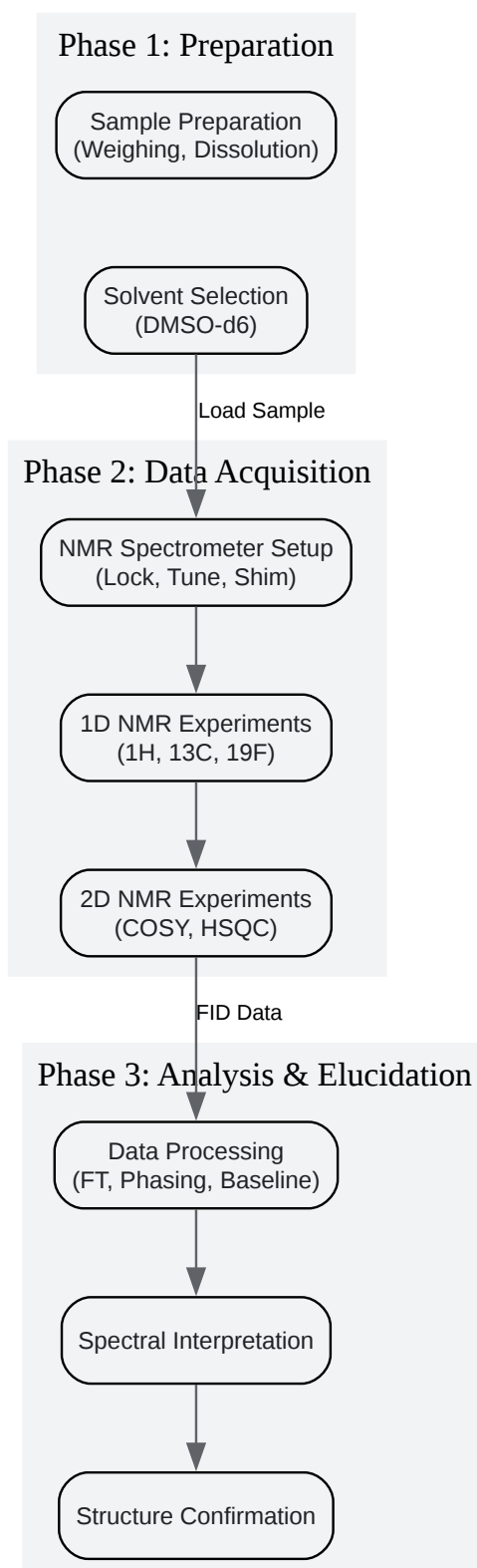

[Click to download full resolution via product page](#)

Caption: Overall workflow for NMR-based structural elucidation.

## Section 2: Experimental Design and Protocols

The quality of NMR data is fundamentally dependent on meticulous sample preparation and correct instrument setup.

### Protocol: Sample Preparation

The choice of solvent is critical. While  $\text{CDCl}_3$  is common, deuterated dimethyl sulfoxide ( $\text{DMSO-d}_6$ ) is highly recommended for benzamides. The amide protons ( $-\text{NH}_2$ ) are acidic and can exchange with trace amounts of  $\text{D}_2\text{O}$  or become very broad in  $\text{CDCl}_3$ ; they are typically well-resolved and observable in the hydrogen-bond-accepting environment of  $\text{DMSO-d}_6$ .<sup>[9][10]</sup>

| Parameter      | Recommendation  | Rationale  |
|----------------|---|--|
| Analyte Mass   | 10-20 mg (for $^1\text{H}$ , $^{19}\text{F}$ , 2D) 50-100 mg (for $^{13}\text{C}$ ) | Balances signal-to-noise (S/N) with solubility and minimizes line broadening from high viscosity. $^{13}\text{C}$ requires more sample due to its lower natural abundance and sensitivity.[11][12] |
| Solvent        | DMSO- $d_6$   | Excellent for dissolving polar benzamides and preserves the amide proton signals. Its residual proton peak (~2.50 ppm) and carbon peaks (~39.52 ppm) are well-documented.[13][14]                  |
| Solvent Volume | 0.6 - 0.7 mL  | Ensures sufficient sample height to be within the detection region of the NMR coil, which is crucial for proper shimming and quantitative accuracy.[15]  |
| NMR Tube       | High-quality, 5 mm tube   | Use clean, unscratched tubes rated for the spectrometer's field strength to ensure optimal magnetic field homogeneity (shimming).[15][16]  |
| Filtration     | Recommended   | Filter the sample into the NMR tube (e.g., through a pipette with a small cotton or glass wool plug) to remove any particulate matter that can severely degrade spectral quality.[12][16]          |

### Step-by-Step Procedure:

- Weigh approximately 15 mg of **3,4-Dichloro-5-fluorobenzamide** directly into a clean, dry vial.
- Add 0.7 mL of DMSO-d<sub>6</sub> to the vial.
- Gently vortex or sonicate the vial to ensure the sample is fully dissolved. A clear solution is essential.[12]
- Using a clean Pasteur pipette, transfer the solution into a labeled 5 mm NMR tube. If any particulates are visible, filter the solution during transfer.
- Cap the NMR tube securely.

## Protocol: NMR Data Acquisition

These protocols are based on a 400 MHz spectrometer but can be adapted. Always perform standard tuning and matching for the respective nuclei and ensure the sample is locked to the deuterium signal of the solvent and properly shimmed.

### 1. <sup>1</sup>H NMR Acquisition:

- Pulse Program: Standard single pulse (e.g., zg30 on Bruker systems).
- Spectral Width (SW): ~16 ppm (e.g., from -2 to 14 ppm).
- Acquisition Time (AQ): ~3-4 seconds.
- Relaxation Delay (D1): 2 seconds.
- Number of Scans (NS): 8-16.

### 2. <sup>13</sup>C{<sup>1</sup>H} NMR Acquisition (Proton-Decoupled):

- Pulse Program: Standard single pulse with proton decoupling (e.g., zgpg30).
- Spectral Width (SW): ~240 ppm (e.g., from -10 to 230 ppm).

- Acquisition Time (AQ): ~1-2 seconds.
- Relaxation Delay (D1): 2 seconds.
- Number of Scans (NS): 1024 or more, depending on concentration.

### 3. $^{19}\text{F}$ NMR Acquisition:

- Pulse Program: Standard single pulse (e.g., zg30).
- Spectral Width (SW): ~200 ppm. The chemical shift range for organofluorine compounds is large; center the spectrum appropriately.<sup>[2]</sup>
- Acquisition Time (AQ): ~1-2 seconds.
- Relaxation Delay (D1): 2 seconds.
- Number of Scans (NS): 16-64.

### 4. 2D $^1\text{H}$ - $^1\text{H}$ COSY Acquisition:

- Pulse Program: Standard COSY sequence (e.g., cosygpqf).
- Spectral Width (SW): ~10 ppm in both F2 and F1 dimensions (covering the proton region).
- Number of Scans (NS): 2-4 per increment.
- Number of Increments (F1): 256-512.

### 5. 2D $^1\text{H}$ - $^{13}\text{C}$ HSQC Acquisition:

- Pulse Program: Standard HSQC sequence with gradient selection (e.g., hsqcedetgpsisp2.3).
- Spectral Width (F2 -  $^1\text{H}$ ): ~10 ppm.
- Spectral Width (F1 -  $^{13}\text{C}$ ): ~160 ppm (covering the aromatic and aliphatic carbon region).
- Number of Scans (NS): 4-8 per increment.

- Number of Increments (F1): 128-256.

## Section 3: Data Processing and Spectral Interpretation

After acquisition, the Free Induction Decay (FID) data must be processed. Standard processing involves Fourier Transformation (FT), phase correction, and baseline correction. This can be accomplished using software like Bruker's TopSpin, Mnova, or SpinWorks.[\[17\]](#)[\[18\]](#)[\[19\]](#)

### Predicted $^1\text{H}$ NMR Spectrum Analysis (in DMSO- $d_6$ )

The structure contains two aromatic protons (H-2, H-6) and two amide protons ( $-\text{NH}_2$ ).

| Proton           | Predicted $\delta$ (ppm) | Predicted Multiplicity                  | Coupling Constant (J, Hz)   | Rationale  |
|------------------|--------------------------|---|---|--|
| -NH <sub>2</sub> | 7.5 - 8.5 (broad)        | Two broad singlets                      | N/A   | Amide protons often appear as two distinct broad signals due to slow rotation around the C-N bond. Their chemical shift is highly dependent on concentration and temperature. [9]                        |
| H-6              | 7.8 - 8.2                | Doublet (d) or Doublet of Doublets (dd) | <sup>3</sup> J <sub>HF</sub> $\approx$ 7-9 Hz,<br><sup>4</sup> J <sub>HH</sub> $\approx$ 2-3 Hz | H-6 is ortho to the electron-withdrawing amide group and meta to a chlorine, leading to a downfield shift. It will show a large 3-bond coupling to <sup>19</sup> F and a smaller 4-bond coupling to H-2. |
| H-2              | 7.6 - 8.0                | Doublet (d)                             | <sup>4</sup> J <sub>HH</sub> $\approx$ 2-3 Hz   | H-2 is ortho to a chlorine atom and para to the fluorine atom. The 4-bond coupling to H-6 will split it into a   |

doublet. Any long-range coupling to  $^{19}\text{F}$  ( $^5\text{JHF}$ ) would be very small.

## Predicted $^{19}\text{F}$ NMR Spectrum Analysis

A single fluorine environment is present. The  $^{19}\text{F}$  spectrum provides direct confirmation and valuable coupling information.

| Nucleus | Predicted $\delta$ (ppm) | Predicted Multiplicity                  | Coupling Constant (J, Hz)  | Rationale  |
|---------|--------------------------|---|--|--|
| F-5     | -110 to -130             | Doublet (d) or Doublet of Doublets (dd) | $^3\text{JFH6} \approx 7-9 \text{ Hz}$ ,<br>$^5\text{JFH2} < 1 \text{ Hz}$ | The fluorine chemical shift is highly sensitive. The primary splitting will be from the 3-bond coupling to H-6. A much smaller 5-bond coupling to H-2 may or may not be resolved. <a href="#">[20]</a> |

## Predicted $^{13}\text{C}\{^1\text{H}\}$ NMR Spectrum Analysis (in DMSO- $d_6$ )

Seven unique carbon signals are expected: one carbonyl and six aromatic carbons. The key feature will be C-F coupling.[\[21\]](#)

| Carbon | Predicted $\delta$ (ppm) | Expected C-F Coupling             | Rationale   |
|--------|--------------------------|-----------------------------------|---|
| C=O    | 165 - 170                | Small ( $^4\text{JCF}$ )          | Typical chemical shift for a benzamide carbonyl carbon.[9]  |
| C-5    | 150 - 160                | Large $^1\text{JCF}$ (240-260 Hz) | Directly bonded to the highly electronegative fluorine atom, causing a large downfield shift and a characteristic large one-bond C-F coupling constant. |
| C-4    | 135 - 145                | $^2\text{JCF}$ (20-30 Hz)         | Carbon atom ortho to fluorine and bonded to chlorine. Will exhibit a two-bond C-F coupling.   |
| C-3    | 125 - 135                | $^3\text{JCF}$ (5-10 Hz)          | Carbon atom meta to fluorine and bonded to chlorine. Will exhibit a three-bond C-F coupling.  |
| C-1    | 130 - 140                | Small ( $^3\text{JCF}$ )          | The ipso-carbon attached to the amide group.  |
| C-6    | 115 - 125                | $^2\text{JCF}$ (20-30 Hz)         | Carbon atom ortho to fluorine and bonded to a proton. Will exhibit a two-bond C-F coupling.   |
| C-2    | 120 - 130                | Small ( $^4\text{JCF}$ )          | Carbon atom para to fluorine and bonded to a proton.  |

## Section 4: Structural Elucidation with 2D NMR

### COSY Analysis

The COSY spectrum is used to confirm proton-proton connectivities. For **3,4-Dichloro-5-fluorobenzamide**, its primary use is to confirm the relationship between the two aromatic protons.

- Expected Correlation: A cross-peak will appear between the signals assigned to H-2 and H-6. This definitively proves they are part of the same spin system and are coupled to each other (via a  $^4J$  coupling).

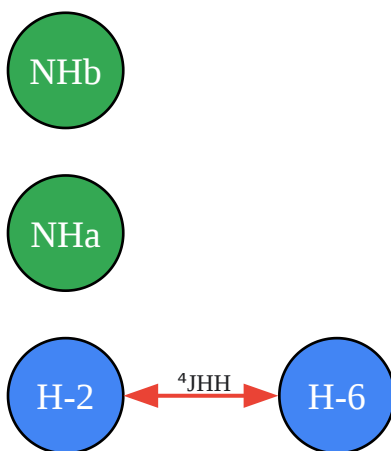

[Click to download full resolution via product page](#)

Caption: Expected  $^1\text{H}$ - $^1\text{H}$  COSY correlation for the aromatic protons.

### HSQC Analysis

The HSQC spectrum is the most powerful tool for assigning the protonated carbons. It creates a direct link between a proton and the carbon it is attached to.

- Expected Correlations:
  - A cross-peak will connect the  $^1\text{H}$  signal of H-2 to the  $^{13}\text{C}$  signal of C-2.
  - A cross-peak will connect the  $^1\text{H}$  signal of H-6 to the  $^{13}\text{C}$  signal of C-6.

This allows for the unambiguous assignment of both H-2/C-2 and H-6/C-6 pairs. Once these are assigned, the remaining quaternary (non-protonated) carbons (C-1, C-3, C-4, C-5) can be assigned based on their predicted chemical shifts and characteristic C-F coupling patterns.

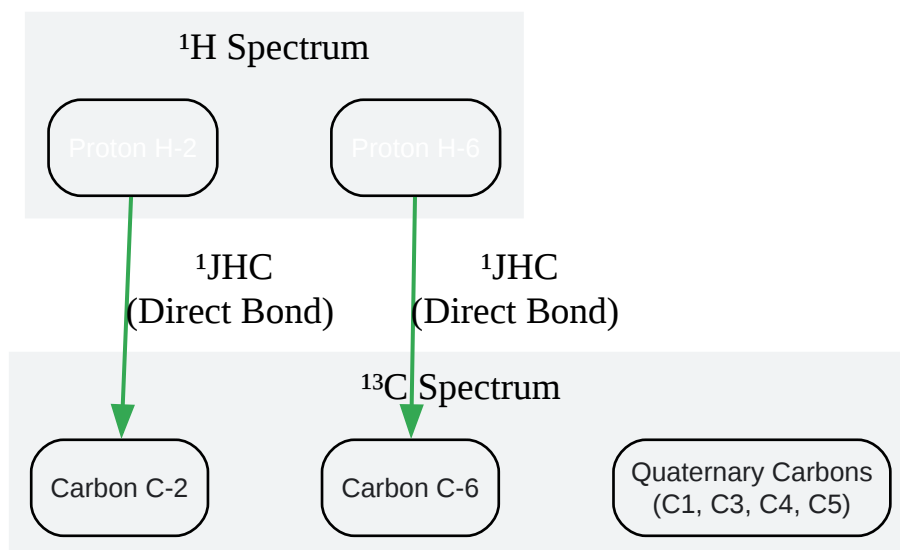

[Click to download full resolution via product page](#)

Caption: Logical correlations expected in the  $^1\text{H}$ - $^{13}\text{C}$  HSQC spectrum.

## Section 5: Conclusion

The structural characterization of **3,4-Dichloro-5-fluorobenzamide** is robustly achieved through a systematic, multi-nuclear NMR approach. By integrating 1D  $^1\text{H}$ ,  $^{13}\text{C}$ , and  $^{19}\text{F}$  spectra with 2D COSY and HSQC correlation data, every protonated and non-protonated atom in the molecule can be assigned with high confidence. The protocols and interpretive guidelines presented here provide a comprehensive roadmap for researchers, ensuring accuracy and reliability in the analysis of this and structurally related compounds, which is paramount in the fields of drug discovery and development.

## References

- Mestrelab Research. (n.d.). Mnova NMR Software for 1D and 2D NMR Data. Retrieved from [\[Link\]](#)

- Iowa State University. (n.d.). NMR Sample Preparation. Chemical Instrumentation Facility. Retrieved from [[Link](#)]
- Bruker. (n.d.). TopSpin | NMR Data Analysis. Retrieved from [[Link](#)]
- CCPN. (n.d.). AnalysisAssign - Software for analysis of biological NMR data. Retrieved from [[Link](#)]
- Georgia Institute of Technology. (n.d.). Recommended Software for NMR Data Process. Retrieved from [[Link](#)]
- University of Florida. (2023, August 29). Small molecule NMR sample preparation. Interdisciplinary Center for Biotechnology Research. Retrieved from [[Link](#)]
- El-Serwy, M. F. (n.d.). Principles and Topical Applications of  $^{19}\text{F}$  NMR Spectrometry. ResearchGate. Retrieved from [[Link](#)]
- Nanalysis. (n.d.). Software Packages – NMR Software to automate and simplify your NMR analysis. Retrieved from [[Link](#)]
- University of Ottawa. (n.d.). Sample preparation. Retrieved from [[Link](#)]
- Michigan State University. (n.d.). Sample Preparation. Max T. Rogers NMR Facility. Retrieved from [[Link](#)]
- Slideshare. (n.d.). Nmr spectroscopy of fluorine 19. Retrieved from [[Link](#)]
- JEOL. (n.d.). HSQC-TOCSY Analysis Understanding 2D NMR Application in Comparison with TOCSY. Retrieved from [[Link](#)]
- ResearchGate. (2007, July 19). Coupling of Protons with Fluorine Page. Retrieved from [[Link](#)]
- Scott, L. G., et al. (n.d.). Measurement of Long Range  $^1\text{H}$ - $^{19}\text{F}$  Scalar Coupling Constants and their Glycosidic Torsion Dependence in 5-Fluoropyrimidine Substituted RNA. PMC. Retrieved from [[Link](#)]

- Prosser, R. S. (2023). A beginner's guide to  $^{19}\text{F}$  NMR and its role in drug screening. *Canadian Journal of Chemistry*, 101(10), 758-764. Retrieved from [\[Link\]](#)
- Emery Pharma. (2018, April 2). A Step-By-Step Guide to 1D and 2D NMR Interpretation. Retrieved from [\[Link\]](#)
- OChemSimplified. (2020, August 10). 2D NMR Spectroscopy: COSY, HSQC (HMQC) and HMBC [Video]. YouTube. Retrieved from [\[Link\]](#)
- Wiberg, K. B., et al. (2018). The halogen effect on the  $^{13}\text{C}$  NMR chemical shift in substituted benzenes. *Magnetic Resonance in Chemistry*, 56(10), 959-964. Retrieved from [\[Link\]](#)
- MDPI. (2024, December 5). Perspectives on Applications of  $^{19}\text{F}$ -NMR in Fragment-Based Drug Discovery. Retrieved from [\[Link\]](#)
- ResearchGate. (n.d.). The halogen effect on the  $^{13}\text{C}$  NMR chemical shift in substituted benzenes. Retrieved from [\[Link\]](#)
- Wikipedia. (n.d.). Two-dimensional nuclear magnetic resonance spectroscopy. Retrieved from [\[Link\]](#)
- San Diego State University. (n.d.). Common 2D (COSY, HSQC, HMBC). SDSU NMR Facility. Retrieved from [\[Link\]](#)
- eGrove. (2021, May 2). Effects of Halogen Bonding on  $^{13}\text{C}$  NMR Shifts of Various Tolan Species. Retrieved from [\[Link\]](#)
- Indian Journal of Chemistry. (n.d.). Some interesting  $^1\text{H}$  NMR features of ortho substituted N-methoxy-N-methyl benzamides. Retrieved from [\[Link\]](#)
- LibreTexts. (n.d.). 13.11 Characteristics of  $^{13}\text{C}$  NMR Spectroscopy. *Organic Chemistry: A Tenth Edition*. Retrieved from [\[Link\]](#)
- Emsley, J. W., & Phillips, L. (1976). Fluorine coupling constants. *Progress in Nuclear Magnetic Resonance Spectroscopy*, 10, 83-756. Retrieved from [\[Link\]](#)

- Wiley Online Library. (2009, May 15).  $^{13}\text{C}$  CP MAS NMR of halogenated (Cl, Br, I) pharmaceuticals at ultrahigh magnetic fields. Retrieved from [[Link](#)]
- University of Missouri-St. Louis. (n.d.). COUPLING CONSTANTS AND STRUCTURE: VICINAL COUPLINGS. Retrieved from [[Link](#)]
- Pearson. (n.d.). How might you use  $^{13}\text{C}$  NMR spectroscopy to differentiate between ortho, meta, and para isomers?. Retrieved from [[Link](#)]
- Royal Society of Chemistry. (n.d.). N-(Benzo[d]thiazol-2-yl)benzamide and its chlorinated isomers: synthesis, NMR, FT-IR, UV-visible, BSA- and DNA-binding, DFT, molecular docking, and pharmacokinetic profiles. New Journal of Chemistry. Retrieved from [[Link](#)]
- ResearchGate. (n.d.). Observed  $^1\text{H}$  NMR chemical shifts ( $\delta$ , ppm) of various aromatic and.... Retrieved from [[Link](#)]
- Oregon State University. (2022, March 9).  $^1\text{H}$  NMR Chemical Shift. Retrieved from [[Link](#)]
- ResearchGate. (n.d.). Conformational analysis, part 43. A theoretical and LIS/NMR investigation of the conformations of substituted benzamides. Retrieved from [[Link](#)]
- Carl ROTH. (n.d.). NMR Chemical Shifts of Common Solvents as Trace Impurities. Retrieved from [[Link](#)]

### Need Custom Synthesis?

BenchChem offers custom synthesis for rare earth carbides and specific isotopic labeling.

Email: [info@benchchem.com](mailto:info@benchchem.com) or [Request Quote Online](#).

## Sources

- 1. [researchgate.net](https://www.researchgate.net) [[researchgate.net](https://www.researchgate.net)]
- 2. [cdnsciencepub.com](https://pubs.cdnsciencepub.com) [[cdnsciencepub.com](https://pubs.cdnsciencepub.com)]
- 3. [benchchem.com](https://www.benchchem.com) [[benchchem.com](https://www.benchchem.com)]
- 4. [mdpi.com](https://www.mdpi.com) [[mdpi.com](https://www.mdpi.com)]

- [5. Two-dimensional nuclear magnetic resonance spectroscopy - Wikipedia \[en.wikipedia.org\]](#)
- [6. 7\) Common 2D \(COSY, HSQC, HMBC\) | SDSU NMR Facility – Department of Chemistry \[nmr.sdsu.edu\]](#)
- [7. emerypharma.com \[emerypharma.com\]](#)
- [8. m.youtube.com \[m.youtube.com\]](#)
- [9. pdf.benchchem.com \[pdf.benchchem.com\]](#)
- [10. Benzamide\(55-21-0\) 1H NMR \[m.chemicalbook.com\]](#)
- [11. NMR Sample Preparation | Chemical Instrumentation Facility \[cif.iastate.edu\]](#)
- [12. mun.ca \[mun.ca\]](#)
- [13. NMR Chemical Shifts of Impurities \[sigmaaldrich.com\]](#)
- [14. carlroth.com \[carlroth.com\]](#)
- [15. Sample Preparation - Max T. Rogers NMR \[nmr.natsci.msu.edu\]](#)
- [16. NMR Sample Preparation | College of Science and Engineering \[cse.umn.edu\]](#)
- [17. Mnova NMR Software for 1D and 2D NMR Data - Mestrelab \[mestrelab.com\]](#)
- [18. TopSpin | NMR Data Analysis | Bruker \[bruker.com\]](#)
- [19. Recommended Software for NMR Data Process – Georgia Tech NMR Center \[sites.gatech.edu\]](#)
- [20. Measurement of Long Range 1H-19F Scalar Coupling Constants and their Glycosidic Torsion Dependence in 5-Fluoropyrimidine Substituted RNA - PMC \[pmc.ncbi.nlm.nih.gov\]](#)
- [21. researchgate.net \[researchgate.net\]](#)
- To cite this document: BenchChem. [Section 1: Foundational Principles and Strategic Approach]. BenchChem, [2026]. [Online PDF]. Available at: [\[https://www.benchchem.com/product/b1410052/docs#section-1-foundational-principles-and-strategic-approach\]](https://www.benchchem.com/product/b1410052/docs#section-1-foundational-principles-and-strategic-approach)

---

### Disclaimer & Data Validity:

The information provided in this document is for Research Use Only (RUO) and is strictly not intended for diagnostic or therapeutic procedures. While BenchChem strives to provide accurate protocols, we make no warranties, express or implied, regarding the fitness of this product for every specific experimental setup.

**Technical Support:** The protocols provided are for reference purposes. Unsure if this reagent suits your experiment?

**Need Industrial/Bulk Grade?** [Request Custom Synthesis Quote](#)

## BenchChem

Our mission is to be the trusted global source of essential and advanced chemicals, empowering scientists and researchers to drive progress in science and industry.

### Contact

Address: 3281 E Guasti Rd  
Ontario, CA 91761, United States  
Phone: (601) 213-4426  
Email: [info@benchchem.com](mailto:info@benchchem.com)

[Contact our Ph.D. Support Team for a compatibility check](#)