

Technical Support Center: Difluoroalkylation Reaction Optimization

Author: BenchChem Technical Support Team. **Date:** May 2026

Compound of Interest

Compound Name: Ethyl 2,2-Difluoropentanoate

CAS No.: 136854-22-3

Cat. No.: B141646

[Get Quote](#)

A Guide for Researchers, Scientists, and Drug Development Professionals

Welcome to the Technical Support Center for difluoroalkylation reactions. As a Senior Application Scientist, I've designed this guide to address the common challenges and subtle nuances of incorporating difluoroalkyl moieties into organic molecules. The selective introduction of groups like $-CF_2R$ and $-CF_2H$ is a cornerstone of modern medicinal chemistry, but these reactions are often plagued by byproduct formation that can derail a synthetic campaign.^{[1][2]}

This resource moves beyond simple protocols to explain the underlying mechanisms of byproduct formation and provides actionable, field-proven troubleshooting strategies.

Frequently Asked Questions (FAQs)

Q1: My difluoroalkylation reaction has stalled, showing low conversion of starting material and multiple

unidentified spots on the TLC plate. What are the likely culprits?

A: This is a classic symptom of competing, non-productive reaction pathways. The primary suspects are:

- **Hydrogen Atom Transfer (HAT):** The generated difluoroalkyl radical is quenched by abstracting a hydrogen atom from the solvent, substrate, or an additive before it can react with your target molecule.[3][4][5] This regenerates the starting material or a reduced version of it and is a very common issue.
- **Photocatalyst Decomposition or Mismatch:** The photocatalyst's excited state may not have the appropriate redox potential to efficiently generate the radical from your specific difluoroalkyl source.[2] Alternatively, the catalyst itself may be unstable under the reaction conditions.
- **Sub-optimal Reaction Concentration:** If the reaction is too dilute, the probability of the difluoroalkyl radical finding and reacting with your substrate decreases, giving it more time to engage in side reactions like HAT.

Q2: What are the most common classes of byproducts I should expect in a radical difluoroalkylation?

A: Besides unreacted starting material, the most prevalent byproducts arise from the high reactivity of the radical intermediates. Key classes include:

- **Proto-dehalogenated Product (R-H):** This results from Hydrogen Atom Transfer (HAT), where the desired difluoroalkyl radical is quenched by a hydrogen source.
- **Dimerization Products:** The difluoroalkyl radical can dimerize with itself ($\text{RCF}_2\text{-CF}_2\text{R}$) or your substrate radical can dimerize.
- **Solvent Adducts:** If the solvent is not robust, the difluoroalkyl radical can add to the solvent molecule, creating an undesired adduct.
- **Oligomers/Polymers:** If your substrate is an alkene, radical polymerization can be a significant side reaction.

Troubleshooting Guide: Common Reaction Failures & Solutions

This section provides a deep dive into specific problems, their mechanistic origins, and validated protocols to overcome them.

Problem Case #1: Dominant Hydrogen Atom Transfer (HAT) Byproduct

Symptoms:

- High recovery of starting material.
- LC-MS or GC-MS analysis shows a significant peak corresponding to the mass of the starting material plus a hydrogen atom (if the reaction is a C-H functionalization) or the simple hydro-de-halogenated starting material.
- Low yield of the desired difluoroalkylated product.

Root Cause Analysis: The core of the issue is a kinetic competition. The difluoroalkyl radical ($\bullet\text{CF}_2\text{R}$) must react with your substrate faster than it abstracts a hydrogen atom from its environment. Solvents with weak C-H bonds are notorious culprits.^{[6][7]} The bond dissociation energy (BDE) is the key parameter; a lower BDE means an easier hydrogen abstraction.^[4]

Visualizing the Competing Pathways The following diagram illustrates the critical branch point where the desired reaction competes with the HAT side reaction.

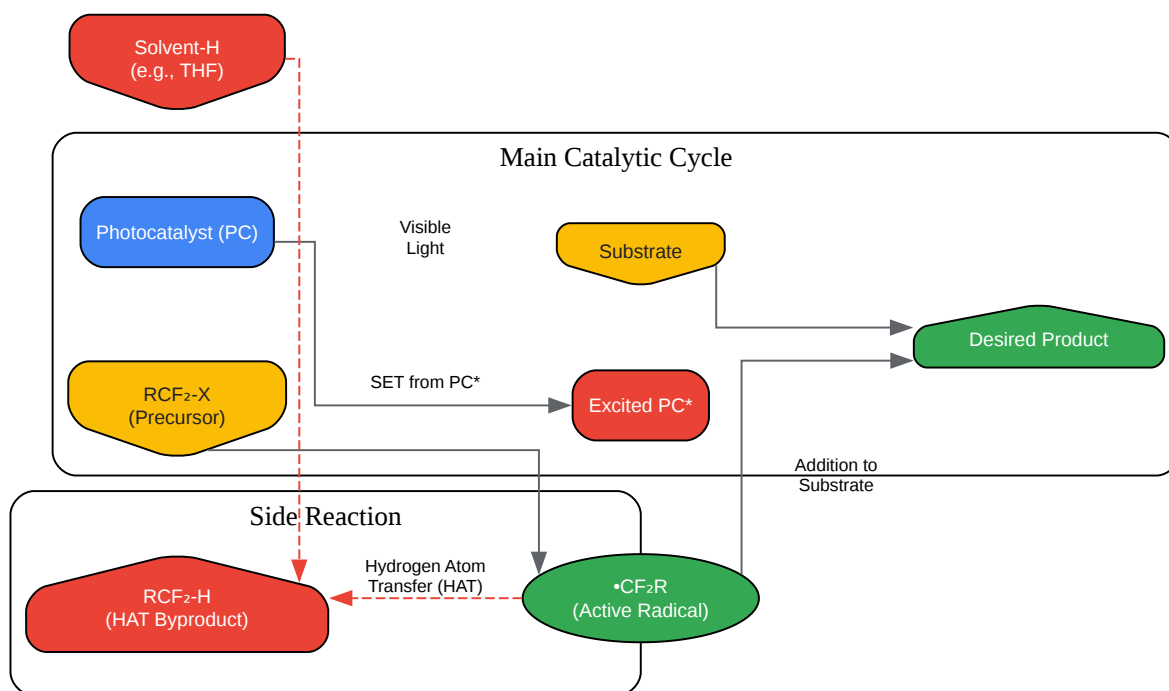

[Click to download full resolution via product page](#)

Caption: Competing pathways for the difluoroalkyl radical.

Solutions & Experimental Protocols:

- **Solvent Selection:** This is the most critical parameter. Avoid solvents known to be good hydrogen atom donors.

Solvent	Relative HAT Rate	BDE (kcal/mol)	Recommendation
Tetrahydrofuran (THF)	High	~92 (α -C-H)	Avoid
1,4-Dioxane	High	~93	Avoid
Toluene	Moderate	~88 (benzylic)	Use with caution
Acetonitrile (MeCN)	Low	~100	Recommended[7]
Dichloromethane (DCM)	Low	~101	Recommended
Benzene / C ₆ D ₆	Very Low	~111	Recommended (Note toxicity)[6]
Hexafluoroisopropanol (HFIP)	Very Low	High	Excellent Choice; can suppress HAT near heteroatoms[4]
tert-Butanol (t-BuOH)	Very Low	~105	Excellent for radical reactions[6]

- Protocol: Solvent Screening for HAT Suppression

1. Setup: Prepare three identical reactions in parallel in sealed vials under an inert atmosphere (e.g., Argon or Nitrogen).

2. Solvents:

- Vial 1: Your original solvent (e.g., THF).
- Vial 2: Acetonitrile (MeCN).
- Vial 3: tert-Butanol (t-BuOH).

3. Concentration: Ensure the substrate concentration is identical across all vials (e.g., 0.1 M).

4. Execution: Run the reactions under identical conditions (light source, temperature, stirring).

5. Analysis: After a set time (e.g., 4 hours), take an aliquot from each vial. Analyze by ^{19}F NMR or LC-MS to compare the ratio of the desired product to the $\text{RCF}_2\text{-H}$ byproduct. This will quantitatively determine the best solvent.
- Increase Reactant Concentration: Doubling the concentration of your substrate can favor the bimolecular reaction with the difluoroalkyl radical over the pseudo-first-order HAT reaction with the solvent.

Problem Case #2: Low Reaction Efficiency and Substrate Degradation

Symptoms:

- Low yield of the desired product.
- Formation of multiple, often inseparable, byproducts.
- Significant consumption of starting material without corresponding product formation.

Root Cause Analysis: This often points to a mismatch between the photocatalyst, the difluoroalkylating agent, and the substrate. The redox potentials must be correctly aligned for efficient Single Electron Transfer (SET) to occur.^[2] If the photocatalyst's excited state reduction potential is not negative enough to reduce the difluoroalkyl precursor, the radical generation will be inefficient. Conversely, an overly oxidizing or reducing photocatalyst can directly react with and degrade your substrate.

Visualizing the Troubleshooting Logic

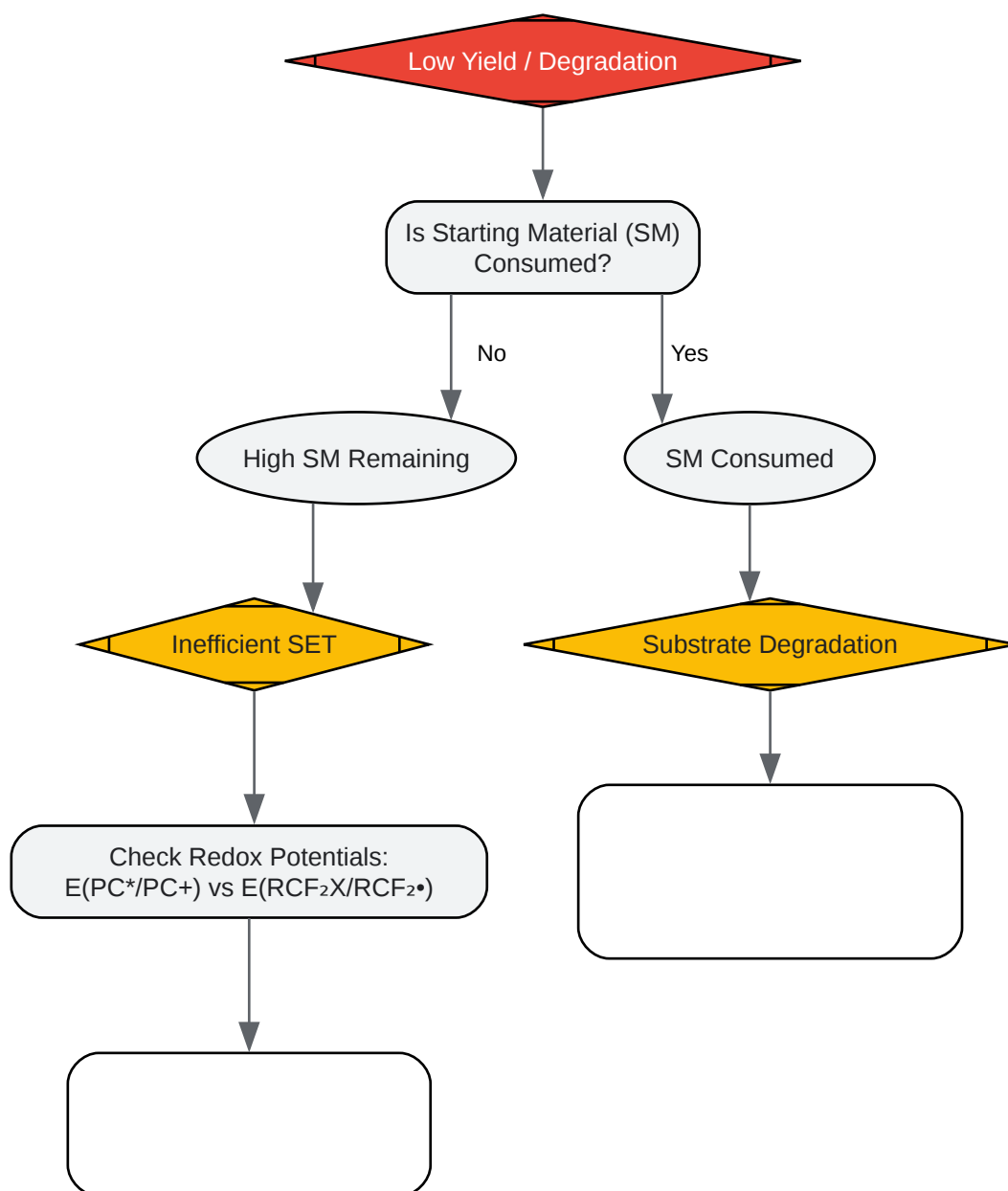

[Click to download full resolution via product page](#)

Caption: Decision tree for troubleshooting low efficiency.

Solutions & Experimental Protocols:

- Reagent and Catalyst Matching: Select a photocatalyst and difluoroalkylating agent with compatible redox potentials.[2][5]

Photocatalyst	$E_{1/2}$ (PC ⁺ /PC [*]) [V vs SCE]	Quenching Cycle	Typical Reagents
fac-Ir(ppy) ₃	-1.73	Oxidative	RCF ₂ -I, RCF ₂ -Br
[Ru(bpy) ₃]Cl ₂	-1.33	Oxidative	RCF ₂ -SO ₂ Cl
4CzIPN (Organic)	-1.35	Oxidative/Reductive	Broadly applicable
Eosin Y (Organic)	-1.66 (Fc ⁺ /Fc)	Oxidative	RCF ₂ -I[8]

- Protocol: Control Experiments for Diagnosing Degradation
 1. Objective: To isolate the component causing substrate degradation.
 2. Setup: Prepare four parallel reactions:
 - Vial A (Full Reaction): Substrate, photocatalyst, RCF₂-X reagent, base/additive, solvent. Irradiate.
 - Vial B (No Light Control): All components from Vial A, but wrapped in aluminum foil.
 - Vial C (No Photocatalyst): All components except the photocatalyst. Irradiate.
 - Vial D (No RCF₂-X): All components except the difluoroalkylating agent. Irradiate.
 3. Execution: Stir all vials under identical conditions for the standard reaction time.
 4. Analysis: Analyze the contents of each vial by LC-MS.
 - If only Vial A shows degradation, the complete reaction cocktail is the issue.
 - If Vials A and D show degradation, the photocatalyst and light are likely degrading your substrate.
 - If Vials A and C show degradation, the RCF₂-X reagent may be reacting directly with the substrate.
- Consider an Alternative Difluoroalkylating Reagent: Reagents vary in their stability and mechanism of radical generation. If using a sulfone-based reagent fails, a halide-based

precursor might work better with a different photocatalyst, or vice-versa.^{[1][2]}

References

- Promising Reagents for Difluoroalkylation. ResearchGate. [\[Link\]](#)
- Progress in Difluoroalkylation of Organic Substrates by Visible Light Photoredox Catalysis. National Institutes of Health (NIH). [\[Link\]](#)
- Catalytic Hydrodifluoroalkylation of Unactivated Olefins. ACS Publications. [\[Link\]](#)
- Catalytic Asymmetric Difluoroalkylation Using In Situ Generated Difluoroenol Species as the Privileged Synthons. National Institutes of Health (NIH). [\[Link\]](#)
- Progress in Difluoroalkylation of Organic Substrates by Visible Light Photoredox Catalysis. europepmc.org. [\[Link\]](#)
- Which organic solvents are resistant to hydrogen atom transfer (HAT) mechanism?. StackExchange. [\[Link\]](#)
- Difluoroalkylation of Anilines via Photoinduced Methods. National Institutes of Health (NIH). [\[Link\]](#)
- Silicon-Based Reagents for Difluoromethylation and Difluoromethylenation Reactions. ResearchGate. [\[Link\]](#)
- Recent Advances in C–H Functionalisation through Indirect Hydrogen Atom Transfer. MDPI. [\[Link\]](#)
- Controlled Fluoroalkylation Reactions by Visible-Light Photoredox Catalysis. ACS Publications. [\[Link\]](#)
- Shelf-stable electrophilic trifluoromethylating reagents: A brief historical perspective. National Institutes of Health (NIH). [\[Link\]](#)
- Difluoroalkylation of Tertiary Amides and Lactams by an Iridium-Catalyzed Reductive Reformatsky Reaction. National Institutes of Health (NIH). [\[Link\]](#)

- Radical Fluoroalkylation Reactions. SciSpace. [[Link](#)]
- Difluoroalkylation/C–H Annulation Cascade Reaction Induced by Visible-Light Photoredox Catalysis. ACS Publications. [[Link](#)]
- Contemporary synthetic strategies in organofluorine chemistry. nature.com. [[Link](#)]
- Optimization of the perfluoroalkoxylation reaction. ResearchGate. [[Link](#)]
- Optimization of the reaction conditions. [a]. ResearchGate. [[Link](#)]
- Photo-induced difluoroalkylation/cyclization of alkyne ketones: a novel strategy to access difluoroalkyl thiofavones. RSC Publishing. [[Link](#)]
- Difluoroalkylation/C-H Annulation Cascade Reaction Induced by Visible-Light Photoredox Catalysis. ResearchGate. [[Link](#)]
- Photoredox-Catalyzed Cascade Difluoroalkylation and Intramolecular Cyclization for Construction of Fluorinated γ -Butyrolactones.. Semantic Scholar. [[Link](#)]
- Radical Fluoroalkylation Reactions. ResearchGate. [[Link](#)]
- Reaction Pathways of Alkoxy Radicals. The Role of Solvent Effects on C–C Bond Fragmentation and Hydrogen Atom Transfer Reactions. ResearchGate. [[Link](#)]
- CF₂H-synthon enables asymmetric radical difluoroalkylation for synthesis of chiral difluoromethylated amines. National Institutes of Health (NIH). [[Link](#)]
- Investigations on 1,2-Hydrogen Atom Transfer Reactivity of Alkoxy Radicals under Visible-Light-Induced Reaction Conditions. ResearchGate. [[Link](#)]
- Excited-state Hydrogen-Atom Transfer Along Solvent Wires: Water Molecules Stop the Transfer. PubMed. [[Link](#)]

Need Custom Synthesis?

BenchChem offers custom synthesis for rare earth carbides and specific isotopic labeling.

Email: info@benchchem.com or [Request Quote Online](#).

Sources

- [1. researchgate.net \[researchgate.net\]](#)
- [2. Progress in Difluoroalkylation of Organic Substrates by Visible Light Photoredox Catalysis - PMC \[pmc.ncbi.nlm.nih.gov\]](#)
- [3. pubs.acs.org \[pubs.acs.org\]](#)
- [4. mdpi.com \[mdpi.com\]](#)
- [5. pubs.acs.org \[pubs.acs.org\]](#)
- [6. chemistry.stackexchange.com \[chemistry.stackexchange.com\]](#)
- [7. researchgate.net \[researchgate.net\]](#)
- [8. Difluoroalkylation of Anilines via Photoinduced Methods - PMC \[pmc.ncbi.nlm.nih.gov\]](#)
- To cite this document: BenchChem. [Technical Support Center: Difluoroalkylation Reaction Optimization]. BenchChem, [2026]. [Online PDF]. Available at: [\[https://www.benchchem.com/product/b141646/docs#technical-support-center-difluoroalkylation-reaction-optimization\]](https://www.benchchem.com/product/b141646/docs#technical-support-center-difluoroalkylation-reaction-optimization)

Disclaimer & Data Validity:

The information provided in this document is for Research Use Only (RUO) and is strictly not intended for diagnostic or therapeutic procedures. While BenchChem strives to provide accurate protocols, we make no warranties, express or implied, regarding the fitness of this product for every specific experimental setup.

Technical Support: The protocols provided are for reference purposes. Unsure if this reagent suits your experiment?

Need Industrial/Bulk Grade? [Request Custom Synthesis Quote](#)

BenchChem

Our mission is to be the trusted global source of essential and advanced chemicals, empowering scientists and researchers to drive progress in science and industry.

Contact

Address: 3281 E Guasti Rd

Ontario, CA 91761, United States

Phone: (601) 213-4426

Email: info@benchchem.com

[Contact our Ph.D. Support Team for a compatibility check](#)