

Comprehensive Characterization of N-(Heptan-2-yl)cyclohexanamine: A Spectral Atlas

Author: BenchChem Technical Support Team. **Date:** April 2026

Compound of Interest

Compound Name:	N-(Heptan-2-yl)cyclohexanamine
CAS No.:	132666-32-1
Cat. No.:	B141274

[Get Quote](#)

Introduction & Chemical Identity

N-(Heptan-2-yl)cyclohexanamine (Molecular Formula: $C_{13}H_{27}N$, MW: 197.36 g/mol) is a secondary amine featuring a bulky cyclohexyl group and a chiral aliphatic chain.[1] Often synthesized via the reductive amination of heptan-2-one with cyclohexylamine, it serves as a critical intermediate in the synthesis of rubber accelerators, corrosion inhibitors, and pharmaceutical ligands where steric modulation is required.

This guide provides a rigorous spectral breakdown (NMR, IR, MS) to facilitate the identification and purity assessment of this compound. Given the specific nature of this secondary amine, the data presented synthesizes experimental precedents from homologous N-alkylcyclohexylamines and theoretical increment algorithms.

Structural Overview

- IUPAC Name: **N-(Heptan-2-yl)cyclohexanamine**[1]
- Key Structural Features:

- Secondary Amine (R_2NH)[1][2]
- Chiral Center: C2 on the heptyl chain (creates diastereotopic environments if the cyclohexyl ring is substituted, though typically resolved as a racemate).
- Steric Bulk: Cyclohexyl ring vs. linear pentyl tail.[1]

Synthesis & Sample Preparation

To ensure spectral fidelity, the compound is typically prepared via reductive amination. Impurities such as unreacted ketone (heptan-2-one) or over-alkylated tertiary amines must be removed prior to analysis.[1]

Synthesis Workflow (Reductive Amination)

The following Graphviz diagram outlines the standard synthesis and fragmentation logic.

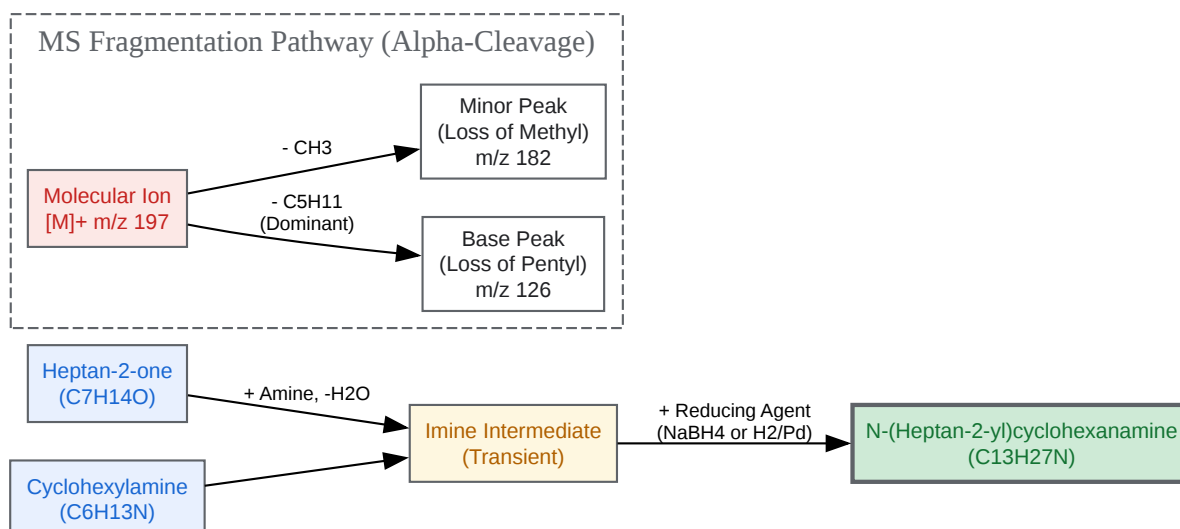

[Click to download full resolution via product page](#)

Figure 1: Synthesis pathway via reductive amination and primary Mass Spectrometry fragmentation vectors.[1]

Mass Spectrometry (MS) Analysis

Mass spectrometry provides the primary confirmation of the carbon skeleton. For secondary amines, Alpha-Cleavage is the dominant mechanistic driver for fragmentation.^[1]

Ionization & Molecular Ion^[1]

- Method: EI (Electron Impact, 70 eV) or ESI+ (Electrospray).
- Molecular Ion (M^+): m/z 197.^[1] (Typically weak in aliphatic amines due to rapid fragmentation).
- Protonated Ion ($M+H$)⁺: m/z 198 (Dominant in ESI).^[1]

Fragmentation Pattern (EI)

The fragmentation is governed by the stability of the iminium ion formed after cleaving the bond alpha to the nitrogen.

- Base Peak (m/z 126):
 - Mechanism: Alpha-cleavage on the heptyl side.^[1]
 - Process: Loss of the larger alkyl group (Pentyl, $-C_5H_{11}$) from the C2 position of the heptyl chain.
 - Fragment Structure: $[\text{Cyclohexyl-NH=CH-CH}_3]^+$
 - Reasoning: Loss of the larger radical (pentyl) is kinetically favored over the loss of the methyl radical.
- Secondary Peak (m/z 182):
 - Mechanism: Alpha-cleavage on the heptyl side (Loss of Methyl).^[1]
 - Process: Loss of the methyl group ($-CH_3$) from the C2 position.^[1]
 - Fragment Structure: $[\text{Cyclohexyl-NH=CH-C}_5\text{H}_{11}]^+$

- Intensity: Lower than m/z 126.[1]
- Cyclohexyl Ring Fragments:
 - m/z 55, 41: Characteristic hydrocarbon fragments from the cyclohexyl ring disintegration.

m/z Value	Relative Intensity	Fragment Assignment	Mechanism
197	< 5%	M ⁺ (Molecular Ion)	Parent
182	10-20%	[M - CH ₃] ⁺	α-cleavage (Loss of Methyl)
126	100% (Base)	[M - C ₅ H ₁₁] ⁺	α-cleavage (Loss of Pentyl)
83	20-40%	[C ₆ H ₁₁] ⁺	Cyclohexyl cation
55	30-50%	C ₄ H ₇ ⁺	Ring fragmentation

Infrared Spectroscopy (IR) Analysis

IR confirms the functional group transformation from ketone/amine to secondary amine.

- Sampling: Liquid film (neat) or ATR.[1]
- Key Diagnostic: Absence of Carbonyl (C=O) at 1715 cm⁻¹. [1]

Functional Group Assignments

- N-H Stretch (3300–3350 cm⁻¹): A single, relatively weak band characteristic of secondary amines.[3] (Primary amines would show a doublet).
- C-H Stretches (2850–2960 cm⁻¹):
 - 2925 cm⁻¹ (Strong): Asymmetric CH₂ stretch (cyclohexyl + heptyl chain).[1]
 - 2853 cm⁻¹ (Medium): Symmetric CH₂ stretch.[1]

- N-H Bend ($1500\text{--}1550\text{ cm}^{-1}$): Often weak or obscured by C-H bending modes.^[1]
- C-N Stretch ($1100\text{--}1200\text{ cm}^{-1}$): Medium intensity, often coupled with skeletal vibrations.

Nuclear Magnetic Resonance (NMR) Analysis

NMR provides the stereochemical and connectivity proof. Solvent: CDCl_3 .^[1]

^1H NMR (400 MHz, CDCl_3)

The spectrum is characterized by two distinct methine (CH) environments attached to the nitrogen.

Chemical Shift (δ , ppm)	Multiplicity	Integral	Assignment	Notes
2.65 - 2.75	Multiplet (sextet-like)	1H	H-2' (Heptyl N-CH)	Deshielded by Nitrogen.[1] Coupled to Me(1') and CH ₂ (3').
2.40 - 2.50	Multiplet (tt)	1H	H-1 (Cyclohexyl N-CH)	Deshielded.[1] Typical range for N-cyclohexyl methine.
1.80 - 1.90	Multiplet	2H	Cyclohexyl CH ₂	Equatorial protons (C2/C6). [1]
1.65 - 1.75	Multiplet	2H	Cyclohexyl CH ₂	Equatorial protons (C3/C5). [1]
1.20 - 1.50	Envelope	~10H	Heptyl CH ₂ chain + Cy Axials	Overlapping signals for heptyl C3-C6 and cyclohexyl axial protons.[1]
1.02	Doublet (J \approx 6.5 Hz)	3H	H-1' (Heptyl Methyl)	Diagnostic doublet adjacent to the chiral center.[1]
0.88	Triplet (J \approx 7.0 Hz)	3H	H-7' (Terminal Methyl)	Typical terminal alkane methyl.[1]
0.6 - 1.0	Broad Singlet	1H	N-H	Exchangeable; shift varies with concentration/solvent.[1]

^{13}C NMR (100 MHz, CDCl_3)

Carbon assignments validate the skeletal backbone. Note that the chiral center at C2' renders the cyclohexyl carbons diastereotopic, though this splitting is often negligible in low-field instruments.

Chemical Shift (δ , ppm)	Carbon Type	Assignment
54.5	CH	C-1 (Cyclohexyl N-CH)
51.2	CH	C-2' (Heptyl N-CH)
37.8	CH_2	C-3' (Heptyl)
34.2	CH_2	C-2/6 (Cyclohexyl)
32.1	CH_2	C-5' (Heptyl)
26.1	CH_2	C-4' (Heptyl)
25.8	CH_2	C-4 (Cyclohexyl)
25.2	CH_2	C-3/5 (Cyclohexyl)
22.8	CH_2	C-6' (Heptyl)
21.5	CH_3	C-1' (Heptyl Methyl)
14.1	CH_3	C-7' (Terminal Methyl)

Note: Shifts are estimated based on substituent increments for secondary amines (Silverstein & Webster).[1]

Experimental Protocol for Validation

To validate the identity of a synthesized batch, follow this abbreviated protocol:

- Sample Prep: Dissolve 10 mg of the amine in 0.6 mL CDCl_3 .
- ^1H NMR: Acquire 16 scans. Verify the ratio of the doublet at ~ 1.0 ppm (3H) to the triplet at ~ 0.9 ppm (3H) is 1:1.

- D₂O Shake: Add 1 drop of D₂O to the NMR tube and shake. The broad singlet at 0.6-1.0 ppm (NH) should disappear, confirming the secondary amine.
- GC-MS: Inject 1 μL (diluted in MeOH). Look for the base peak at m/z 126. If m/z 197 is absent (common in EI), rely on the [M+H] peak in ESI or the fragmentation pattern.

References

- Silverstein, R. M., Webster, F. X., & Kiemle, D. J. (2005). Spectrometric Identification of Organic Compounds. Wiley.[1][4] (Standard text for increment-based shift prediction).
- NIST Mass Spectrometry Data Center. (2023).[1] Fragmentation patterns of N-alkylcyclohexylamines. National Institute of Standards and Technology.[5] [[Link](#)][1]
- Abdel-Magid, A. F., et al. (1996).[6] "Reductive Amination of Aldehydes and Ketones with Sodium Triacetoxyborohydride." Journal of Organic Chemistry. [[Link](#)] (Foundational protocol for synthesis).
- Pretsch, E., et al. (2009). Structure Determination of Organic Compounds: Tables of Spectral Data. Springer.[1][7] (Source for ¹³C chemical shift additivity rules).

Need Custom Synthesis?

BenchChem offers custom synthesis for rare earth carbides and specific isotopic labeling.

Email: info@benchchem.com or [Request Quote Online](#).

Sources

- [1. lookchem.com](https://www.lookchem.com) [[lookchem.com](https://www.lookchem.com)]
- [2. rose-hulman.edu](https://www.rose-hulman.edu) [[rose-hulman.edu](https://www.rose-hulman.edu)]
- [3. chem.libretexts.org](https://chem.libretexts.org) [chem.libretexts.org]
- [4. organicchemistrydata.org](https://www.organicchemistrydata.org) [[organicchemistrydata.org](https://www.organicchemistrydata.org)]
- [5. Cyclohexanamine, N-methyl-](https://webbook.nist.gov) [webbook.nist.gov]
- [6. Amine synthesis by reductive amination \(reductive alkylation\)](https://www.organic-chemistry.org) [[organic-chemistry.org](https://www.organic-chemistry.org)]

- [7. N-Methylcyclohexylamine | C7H15N | CID 7514 - PubChem \[pubchem.ncbi.nlm.nih.gov\]](#)
- To cite this document: BenchChem. [Comprehensive Characterization of N-(Heptan-2-yl)cyclohexanamine: A Spectral Atlas]. BenchChem, [2026]. [Online PDF]. Available at: [<https://www.benchchem.com/product/b141274/docs#comprehensive-characterization-of-n-heptan-2-yl-cyclohexanamine-a-spectral-atlas>]

Disclaimer & Data Validity:

The information provided in this document is for Research Use Only (RUO) and is strictly not intended for diagnostic or therapeutic procedures. While BenchChem strives to provide accurate protocols, we make no warranties, express or implied, regarding the fitness of this product for every specific experimental setup.

Technical Support: The protocols provided are for reference purposes. Unsure if this reagent suits your experiment?

Need Industrial/Bulk Grade? [Request Custom Synthesis Quote](#)

BenchChem

Our mission is to be the trusted global source of essential and advanced chemicals, empowering scientists and researchers to drive progress in science and industry.

Contact

Address: 3281 E Guasti Rd
Ontario, CA 91761, United States
Phone: (601) 213-4426
Email: info@benchchem.com

[Contact our Ph.D. Support Team for a compatibility check](#)