

# Technical Support Center: Regioselective Functionalization of Benzothiophenes[1]

**Author:** BenchChem Technical Support Team. **Date:** April 2026

## Compound of Interest

Compound Name:	Cyclohexanol, 1-benzo[b]thien-2-yl-
CAS No.:	6774-43-2
Cat. No.:	B14081530

[Get Quote](#)

Welcome to the Advanced Synthesis Support Module. As a Senior Application Scientist, I understand that benzothiophene functionalization is rarely about "making it react"—it is about making it react where you want it to. The electronic dichotomy between the thiophene ring (electron-rich, heterocyclic) and the fused benzene ring creates a complex reactivity landscape.

This guide addresses the most frequent regioselectivity failures we encounter in the field. It is structured to troubleshoot specific observed issues, explain the mechanistic causality, and provide self-validating protocols to correct them.

## Visualizing the Reactivity Landscape

Before troubleshooting, verify your target against the intrinsic reactivity map of the benzothiophene scaffold.

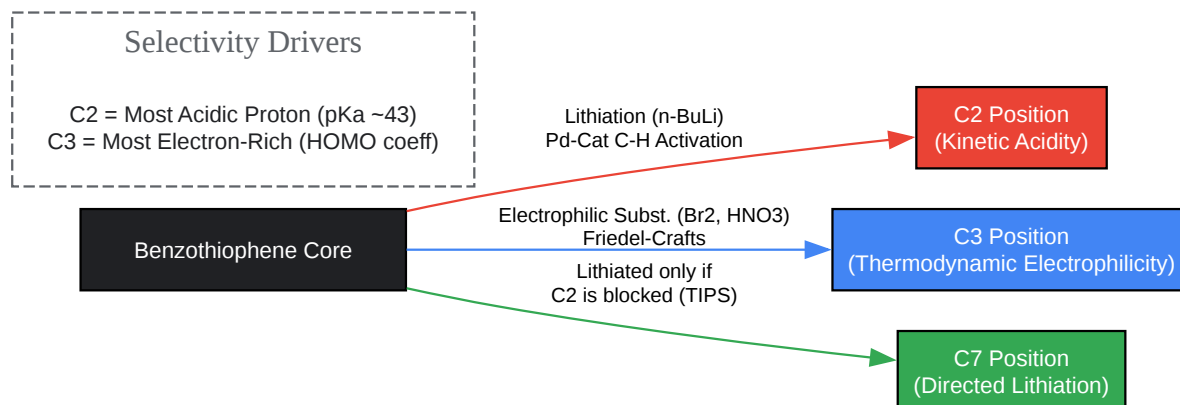

[Click to download full resolution via product page](#)

Figure 1: Intrinsic reactivity preferences of the benzothiophene scaffold. C2 dominates nucleophilic/base-mediated chemistry, while C3 dominates electrophilic chemistry.

## Module 1: Electrophilic Aromatic Substitution (EAS)

Target: C3-Functionalization (Halogenation, Acylation)

Issue 1: "I am observing a mixture of C3 (major) and C2 (minor) isomers during bromination."

Diagnosis: While C3 is the thermodynamically preferred site for electrophilic attack (due to the stability of the Wheland intermediate preserving the benzene aromaticity), the activation energy difference between C2 and C3 is not insurmountable. High temperatures or highly reactive electrophiles can erode selectivity.[2]

Troubleshooting Protocol:

- Thermodynamic Control: Lower the reaction temperature to 0°C or -78°C.
- Reagent Switch: Swap elemental bromine ( ) for N-Bromosuccinimide (NBS) in a polar aprotic solvent (DMF or Acetonitrile). NBS provides a lower concentration of the active bromonium species, favoring the lower-energy C3 transition state.

- Solvent Polarity: Use Acetonitrile.[2] It stabilizes the cationic intermediate, enhancing the selectivity for the C3 position over the less stable C2 intermediate.

Self-Validating Check:

- Run TLC/LCMS.[2][3] The C3-bromo isomer is typically more polar than the C2 isomer in non-polar mobile phases due to the dipole moment alignment.

**Issue 2: "I cannot functionalize C3 without over-halogenating or polymerizing."**

Diagnosis: The product (3-bromobenzothiophene) is less electron-rich than the starting material, but not sufficiently deactivated to prevent a second attack if the electrophile concentration is high.

Corrective Workflow:

- Stoichiometry: Use exactly 0.95 - 1.0 equivalents of electrophile.
- Protocol: Add the electrophile dropwise to the benzothiophene solution (inverse addition) to ensure the substrate is always in excess until the end.

## Module 2: Lithiation and Metalation

Target: C2-Functionalization or C3-Nucleophiles

**Issue 3: "I treated benzothiophene with n-BuLi intending to trap at C3, but I isolated the C2 product."**

Diagnosis: This is a classic "Kinetic vs. Thermodynamic" error.[2] The proton at C2 is significantly more acidic (kinetic acidity) due to the inductive effect of the sulfur atom. Direct lithiation with n-BuLi will always occur at C2 exclusively.[2]

The "Blocking Group" Strategy (For C3 Access): You cannot directly lithiate C3 efficiently on an unsubstituted ring. You must force the regioselectivity.

Step-by-Step Protocol:

- Block C2: React benzothiophene with n-BuLi followed by TMSCl (Trimethylsilyl chloride).
  - Result: 2-(trimethylsilyl)benzothiophene.[4]
- Halogen Dance / Exchange: Brominate C3 (using the EAS method from Module 1).
  - Result: 3-bromo-2-(trimethylsilyl)benzothiophene.
- Lithium-Halogen Exchange: Treat with t-BuLi or n-BuLi at -78°C. The Lithium prefers the C3-Br exchange over the C2-Si cleavage.
  - Result: C3-Lithiated species ready for your electrophile.[2]
- Deprotection: Remove the TMS group with TBAF.

Data Summary: Lithiation Selectivity

Reagent	Substrate	Temp	Major Product (Quenched)	Mechanism
n-BuLi	Benzothiophene	-78°C	C2-Li (>99%)	Kinetic Deprotonation
t-BuLi	3-Bromobenzothiophene	-78°C	C3-Li (>95%)	Halogen-Lithium Exchange
LDA	Benzothiophene	-78°C	C2-Li (>99%)	Kinetic Deprotonation

## Module 3: Advanced C-H Activation (Metal-Free)

Target: Direct C3-Arylation without Halogens

Issue 4: "I want to arylate C3 directly, but Pd-catalysis is giving me C2/C3 mixtures or requires harsh conditions."

Diagnosis: Transition metal catalysis (Pd/Ru) often struggles to distinguish between the C2 and C3 C-H bonds without a directing group. The "Modern" solution is the Interrupted Pummerer

Rearrangement using Benzothiophene S-oxides.[5] This method is strictly C3-selective.[2]

The S-Oxide Protocol (Procter Method): This method uses the sulfur atom itself to direct the incoming nucleophile to C3.

- Oxidation: Oxidize benzothiophene to the S-oxide (sulfoxide) using a controlled oxidant (e.g., in HFIP). Note: Avoid over-oxidation to the sulfone.
- Activation: Treat the S-oxide with Trifluoroacetic Anhydride (TFAA). This activates the sulfoxide.
- Coupling: Add an electron-rich arene (e.g., phenol, anisole).
- Mechanism: The nucleophile attacks the activated intermediate, followed by a [3,3]-sigmatropic rearrangement that delivers the aryl group exclusively to C3.
- Restoration: The aromaticity is restored, and the sulfur is reduced back to the sulfide in situ or with a mild reductant.

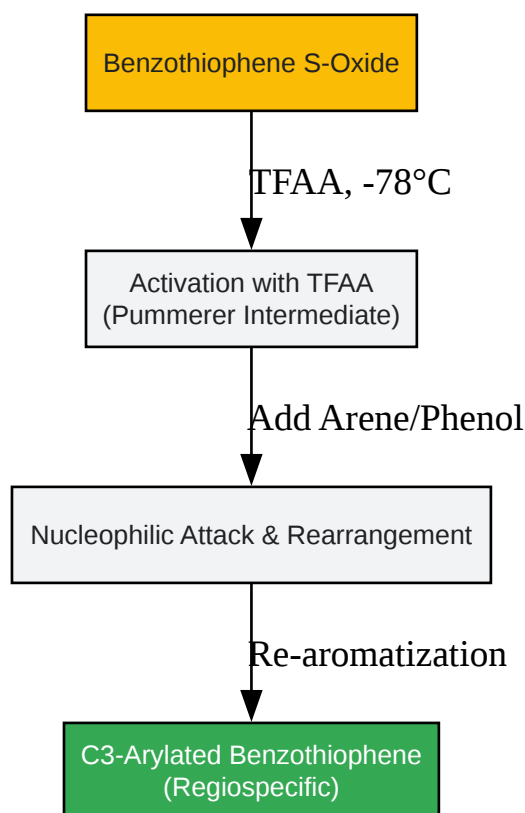

[Click to download full resolution via product page](#)

Figure 2: The S-Oxide "Interrupted Pummerer" strategy for metal-free, regiospecific C3 functionalization.

## Module 4: Functionalizing the Benzene Ring

Target: C7-Functionalization

Issue 5: "I need to functionalize the benzene ring (C7), but the thiophene ring keeps reacting."

Diagnosis: The thiophene ring is far more reactive than the benzene ring.<sup>[5]</sup> To hit C7 (the position ortho to the sulfur on the benzene ring), you must sterically shield the thiophene ring.

The "Super-Silyl" Shield Protocol:

- Protection: Install a bulky Triisopropylsilyl (TIPS) group at C2.<sup>[2]</sup>
  - Why TIPS? TMS is too small.<sup>[2]</sup> TIPS exerts a steric influence that discourages aggregation and reaction near the sulfur.
- Directed Lithiation: Treat 2-TIPS-benzothiophene with n-BuLi / TMEDA.<sup>[2]</sup>
  - Mechanism:<sup>[6][7][8][9][10][11]</sup> The sulfur atom acts as a Weak Coordinating Group (WCG). With C2 blocked by a massive TIPS group, the lithium complex is directed to the next most accessible position coordinated by the sulfur lone pair: C7.
- Quench: Add your electrophile.

## References

- BenchChem.Application Notes and Protocols for C3 Functionalization of the Benzothiophene Ring. (Accessed 2024).<sup>[2]</sup> [Link](#)
- Shriver, H. J., et al. "Regioselective synthesis of C3 alkylated and arylated benzothiophenes."<sup>[12]</sup> Nature Communications, 8, 14801 (2017).<sup>[7][12]</sup> [Link](#)<sup>[7]</sup>

- Tian, B., et al. "Gold-Catalyzed Intermolecular Alkyne Oxyarylation for C3 Functionalization of Benzothiophenes." *Organic Letters*, 23(3), 642–646 (2021). [\[6\]\[13\]](#) [Link\[6\]\[13\]](#)
- Luo, J., et al. "Nickel-catalyzed and Li-mediated regiospecific C–H arylation of benzothiophenes." *Green Chemistry*, 22, 1120-1124 (2020). [Link](#)
- Becht, J.-M., et al. "Lithiated Benzothiophenes and Benzofurans Require 2-Silyl Protection to Avoid Anion Migration." *Chemistry - A European Journal*, 17, 1234 (2011). [Link](#)

### Need Custom Synthesis?

BenchChem offers custom synthesis for rare earth carbides and specific isotopic labeling.

Email: [info@benchchem.com](mailto:info@benchchem.com) or [Request Quote Online](#).

## Sources

- 1. [benchchem.com](https://www.benchchem.com) [[benchchem.com](https://www.benchchem.com)]
- 2. [youtube.com](https://www.youtube.com) [[youtube.com](https://www.youtube.com)]
- 3. [researchgate.net](https://www.researchgate.net) [[researchgate.net](https://www.researchgate.net)]
- 4. [researchgate.net](https://www.researchgate.net) [[researchgate.net](https://www.researchgate.net)]
- 5. [pdf.benchchem.com](https://pdf.benchchem.com) [[pdf.benchchem.com](https://pdf.benchchem.com)]
- 6. [pure-oai.bham.ac.uk](https://pure-oai.bham.ac.uk) [[pure-oai.bham.ac.uk](https://pure-oai.bham.ac.uk)]
- 7. [researchgate.net](https://www.researchgate.net) [[researchgate.net](https://www.researchgate.net)]
- 8. Nickel-catalyzed and Li-mediated regiospecific C–H arylation of benzothiophenes - *Green Chemistry* (RSC Publishing) [[pubs.rsc.org](https://pubs.rsc.org)]
- 9. High Site Selectivity in Electrophilic Aromatic Substitutions: Mechanism of C–H Thianthrenation - PMC [[pubmed.ncbi.nlm.nih.gov](https://pubmed.ncbi.nlm.nih.gov)]
- 10. [researchgate.net](https://www.researchgate.net) [[researchgate.net](https://www.researchgate.net)]
- 11. Regioselective synthesis of C3 alkylated and arylated benzothiophenes - PMC [[pubmed.ncbi.nlm.nih.gov](https://pubmed.ncbi.nlm.nih.gov)]
- 12. Regioselective synthesis of C3 alkylated and arylated benzothiophenes - PubMed [[pubmed.ncbi.nlm.nih.gov](https://pubmed.ncbi.nlm.nih.gov)]

- [13. Gold-Catalyzed Intermolecular Alkyne Oxyarylation for C3 Functionalization of Benzothiophenes - PubMed \[pubmed.ncbi.nlm.nih.gov\]](#)
- To cite this document: BenchChem. [Technical Support Center: Regioselective Functionalization of Benzothiophenes[1]]. BenchChem, [2026]. [Online PDF]. Available at: [<https://www.benchchem.com/product/b14081530/docs#technical-support-center-regioselective-functionalization-of-benzothiophenes-1>]

---

### Disclaimer & Data Validity:

The information provided in this document is for Research Use Only (RUO) and is strictly not intended for diagnostic or therapeutic procedures. While BenchChem strives to provide accurate protocols, we make no warranties, express or implied, regarding the fitness of this product for every specific experimental setup.

**Technical Support:** The protocols provided are for reference purposes. Unsure if this reagent suits your experiment?

**Need Industrial/Bulk Grade?** [Request Custom Synthesis Quote](#)

## BenchChem

Our mission is to be the trusted global source of essential and advanced chemicals, empowering scientists and researchers to drive progress in science and industry.

### Contact

Address: 3281 E Guasti Rd  
Ontario, CA 91761, United States  
Phone: (601) 213-4426  
Email: [info@benchchem.com](mailto:info@benchchem.com)

[Contact our Ph.D. Support Team for a compatibility check](#)