

GC-MS Retention & Analysis Guide: Trifluoromethylated Pyridine Intermediates

Author: BenchChem Technical Support Team. **Date:** February 2026

Compound of Interest

Compound Name: *6-Fluoro-3-iodo-2-(trifluoromethyl)pyridine*

CAS No.: 1227561-59-2

Cat. No.: B1408522

[Get Quote](#)

Executive Summary

Trifluoromethylpyridines are critical pharmacophores in modern medicinal chemistry, offering enhanced metabolic stability and lipophilicity compared to their methyl or chloro analogs. However, their high volatility and unique electronic properties (the "fluorous effect") create specific analytical challenges.

This guide provides a validated framework for separating and identifying regioisomers (2-, 3-, and 4-

) using Gas Chromatography-Mass Spectrometry (GC-MS). Unlike Liquid Chromatography (LC), where the electron-withdrawing

group often leads to poor retention on C18 phases, GC utilizes the volatility of these compounds for superior resolution.

Comparative Retention Behavior

The elution order of trifluoromethylpyridines on standard non-polar columns (e.g., 5% phenylmethylpolysiloxane) is primarily governed by boiling point, which is heavily influenced by the dipole moment of the pyridine ring relative to the

group.

Isomer Separation Profile (Non-Polar Phase)

Column Type: DB-5ms, HP-5ms, or equivalent (30m x 0.25mm x 0.25 μ m). Elution Order: 4-isomer

3-isomer

2-isomer.

Compound	Structure	Boiling Point	Relative Elution (DB-5)	Key MS Fragment Ions (EI, 70eV)
4-(Trifluoromethyl)pyridine	Para-subst.	108-110 °C	1st (Fastest)	,
3-(Trifluoromethyl)pyridine	Meta-subst.	113-115 °C	2nd	,
2-(Trifluoromethyl)pyridine	Ortho-subst.	139-141 °C	3rd (Slowest)	,

“

Critical Insight: The 2-isomer elutes significantly later than the 3- and 4-isomers due to a stronger molecular dipole and steric shielding of the nitrogen lone pair, which increases effective boiling point. This separation is robust and typically does not require polar WAX columns unless complex co-eluting matrix components are present.

Comparison with Alternatives

Feature	Trifluoromethyl () Pyridines	Methyl () Pyridines	Chloro () Pyridines
Volatility	High (Elutes early)	Moderate	Low (Elutes later)
MS Signature	Distinctive loss of 69 Da ()	Loss of 1 Da () or 15 Da ()	Isotope pattern (3:[1]1)
Peak Shape	Sharp, minimal tailing on deactivated columns	Prone to tailing (basic N interaction)	Sharp, generally symmetric

Experimental Protocol

This protocol is designed to be self-validating. If the retention order of the test mix does not match Section 2, the column activity or flow rate is compromised.

A. Sample Preparation[2]

- Solvent: Dichloromethane (DCM) or Methyl tert-butyl ether (MTBE). Avoid Methanol (can react with activated intermediates).
- Concentration: 50–100 ppm ($\mu\text{g/mL}$).
- Derivatization: Not required for

-pyridines. If analyzing acidic metabolites (e.g., trifluoromethyl-nicotinic acid), derivatize with BSTFA/TMCS (99:1) at 60°C for 30 mins.

B. GC-MS Method Parameters

- Inlet: Split mode (20:1 to 50:1), 250°C. Note: High split ratio prevents column overload common with volatile fluorinated species.
- Carrier Gas: Helium at 1.0 mL/min (Constant Flow).

- Oven Program:
 - Hold at 40°C for 2 min (Critical for resolving volatile 4-isomer from solvent).
 - Ramp 10°C/min to 150°C.
 - Ramp 25°C/min to 280°C, hold 3 min.
- MS Source: 230°C, EI mode (70 eV).
- Scan Range:m/z 40–300.

C. Mass Spectral Identification Logic

- Check Molecular Ion (): All isomers show a clear at m/z 147.
- Look for Neutral Loss:
 - (Loss of): Dominant in 2-isomer.
 - (Loss of): Often seen in 3- and 4-isomers due to benzylic-type stability.
- Confirm Ring Fragment:m/z 78 (Pyridine ring) indicates the core structure is intact after de-fluorination.

Analytical Workflow Diagram

The following diagram illustrates the decision-making process for analyzing reaction mixtures containing these intermediates.

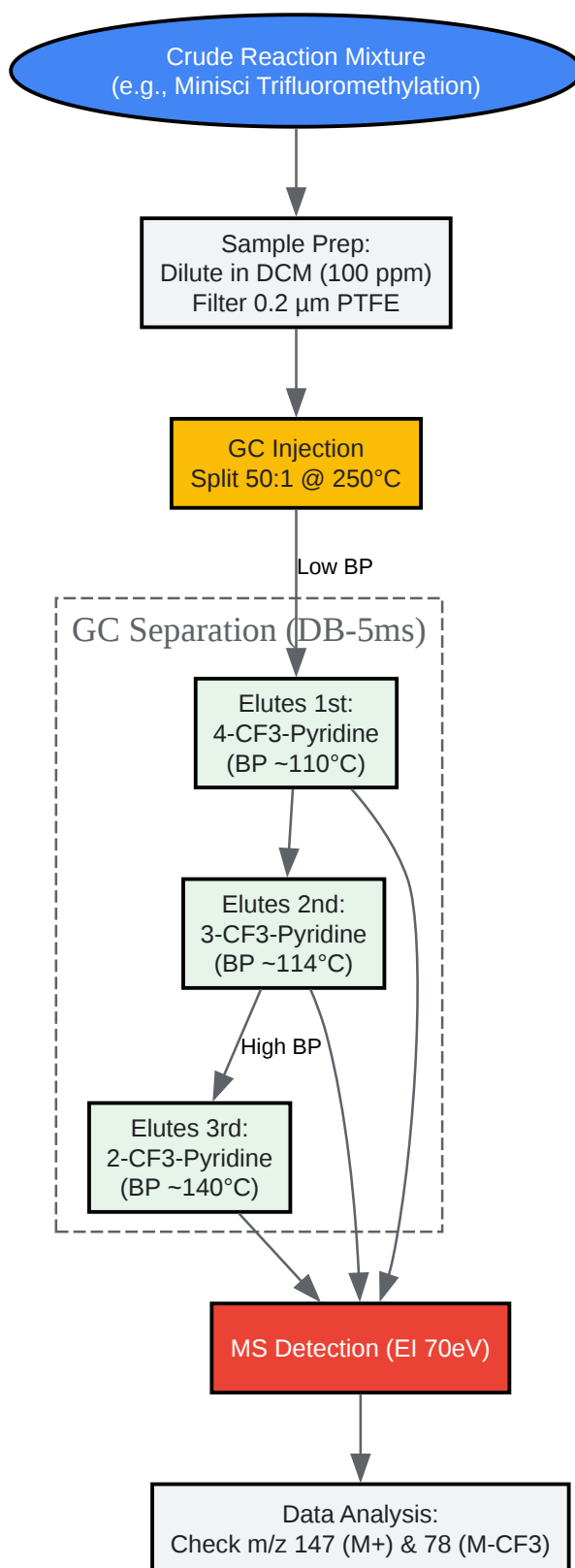

[Click to download full resolution via product page](#)

Figure 1: Analytical workflow for separating trifluoromethylpyridine regioisomers based on boiling point elution order.

Troubleshooting & Optimization

Issue	Probable Cause	Corrective Action
Peak Tailing	Active sites in liner or column interacting with basic pyridine Nitrogen.	Use Ultra Inert liners with wool. Trim column head (10-20 cm).
Co-elution	Solvent peak overlaps with 4-trifluoromethylpyridine (very volatile).	Start oven at 35°C or 40°C. Use a solvent with higher BP (e.g., Toluene) if chemistry permits, or lower BP (Pentane).
Missing Peaks	High volatility caused sample loss during concentration (Rotavap).	Do not evaporate to dryness. Use a keeper solvent or analyze crude directly after dilution.

References

- PubChem. (2025).[2] 2-(Trifluoromethyl)pyridine Physical Properties. National Library of Medicine. [\[Link\]](#)
- NIST Mass Spectrometry Data Center. (2025). Mass Spectrum of 2-Chloro-4-trifluoromethylpyridine. National Institute of Standards and Technology.[1] [\[Link\]](#)

Need Custom Synthesis?

BenchChem offers custom synthesis for rare earth carbides and specific isotopic labeling.

Email: info@benchchem.com or [Request Quote Online](#).

Sources

- [1. researchgate.net \[researchgate.net\]](https://www.researchgate.net)

- [2. 4-\(Trifluoromethyl\)pyridine | C6H4F3N | CID 138055 - PubChem](#)
[pubchem.ncbi.nlm.nih.gov]
- To cite this document: BenchChem. [GC-MS Retention & Analysis Guide: Trifluoromethylated Pyridine Intermediates]. BenchChem, [2026]. [Online PDF]. Available at: [https://www.benchchem.com/product/b1408522#gc-ms-retention-times-for-trifluoromethylated-pyridine-intermediates]

Disclaimer & Data Validity:

The information provided in this document is for Research Use Only (RUO) and is strictly not intended for diagnostic or therapeutic procedures. While BenchChem strives to provide accurate protocols, we make no warranties, express or implied, regarding the fitness of this product for every specific experimental setup.

Technical Support: The protocols provided are for reference purposes. Unsure if this reagent suits your experiment? [[Contact our Ph.D. Support Team for a compatibility check](#)]

Need Industrial/Bulk Grade? [Request Custom Synthesis Quote](#)

BenchChem

Our mission is to be the trusted global source of essential and advanced chemicals, empowering scientists and researchers to drive progress in science and industry.

Contact

Address: 3281 E Guasti Rd
Ontario, CA 91761, United States
Phone: (601) 213-4426
Email: info@benchchem.com