

# Technical Guide: Comparative Analysis of Azido-PEG2-thiol and Azido-PEG3-thiol

**Author:** BenchChem Technical Support Team. **Date:** May 2026

## Compound of Interest

**Compound Name:** 2-(2-(2-Azidoethoxy)ethoxy)ethane-1-thiol

**Cat. No.:** B14075388

[Get Quote](#)

## Executive Summary

In the rational design of heterobifunctional crosslinkers, the difference of a single ethylene glycol unit ( $-\text{CH}_2\text{CH}_2\text{O}-$ ) is often trivialized. However, in sensitive applications such as Proteolysis Targeting Chimeras (PROTACs), Antibody-Drug Conjugates (ADCs), and Self-Assembled Monolayers (SAMs), this difference dictates the boundary between a functional therapeutic and an inactive artifact.

Azido-PEG2-thiol (shorter, rigid) and Azido-PEG3-thiol (longer, flexible) represent a critical decision point. The PEG2 variant offers higher surface density and reduced hydrodynamic drag, while the PEG3 variant provides essential conformational freedom to overcome steric hindrance in ternary complex formation. This guide dissects these properties to enable evidence-based selection.

## Physicochemical Characterization

The nomenclature "PEGn" can be ambiguous in commercial catalogs. For this guide, we define the structures based on their precise chemical formulas and backbone composition verified by mass spectrometry standards.

## Structural & Property Comparison

Feature	Azido-PEG2-thiol	Azido-PEG3-thiol
Formula	C <sub>6</sub> H <sub>13</sub> N <sub>3</sub> O <sub>2</sub> S	C <sub>8</sub> H <sub>17</sub> N <sub>3</sub> O <sub>3</sub> S
Molecular Weight	~191.25 Da	~235.33 Da
Backbone Length (Est.)	~10.5 Å	~14.0 Å
Ether Oxygen Atoms	2	3
Ethylene Segments	3 (-CH <sub>2</sub> CH <sub>2</sub> -)	4 (-CH <sub>2</sub> CH <sub>2</sub> -)
Hydrophilicity (LogP)	Moderate (More Lipophilic)	High (More Hydrophilic)
Water Solubility	High	Very High
Primary Utility	High-density surface packing, short-range crosslinking	Steric relief, PROTAC linker optimization

Key Insight: The transition from PEG2 to PEG3 introduces approximately 3.5 Å of additional reach and one rotational degree of freedom. This seemingly minor extension significantly lowers the energy barrier for the "folding" required in many ligand-protein interactions.

## Mechanistic Implications in Bioconjugation

### The "Goldilocks" Zone in PROTAC Design

In PROTAC development, the linker must span the gap between the Target Protein (POI) and the E3 Ligase.

- **PEG2 Limitations:** Often too short to allow the simultaneous binding of both warheads without inducing steric clashes between the two proteins. This results in "hook effects" where binary complexes form (Linker-POI or Linker-E3) but the ternary complex (POI-Linker-E3) is energetically unfavorable.
- **PEG3 Advantages:** The extra ether unit frequently provides just enough slack to permit the necessary protein-protein interactions (PPI) required for ubiquitination.

## Surface Chemistry (SAMs on Gold)

When forming Self-Assembled Monolayers on gold surfaces (via the Thiol group):

- Azido-PEG2-thiol: Forms a denser monolayer due to reduced excluded volume of the headgroup. This is advantageous for maximizing azide density for subsequent click reactions but may lead to steric crowding that inhibits the incoming alkyne.
- Azido-PEG3-thiol: Forms a slightly less dense but more ordered monolayer. The longer chain provides a "cushion" that suppresses non-specific protein adsorption (fouling) more effectively than PEG2.

## Visualizing the Mechanistic Pathway

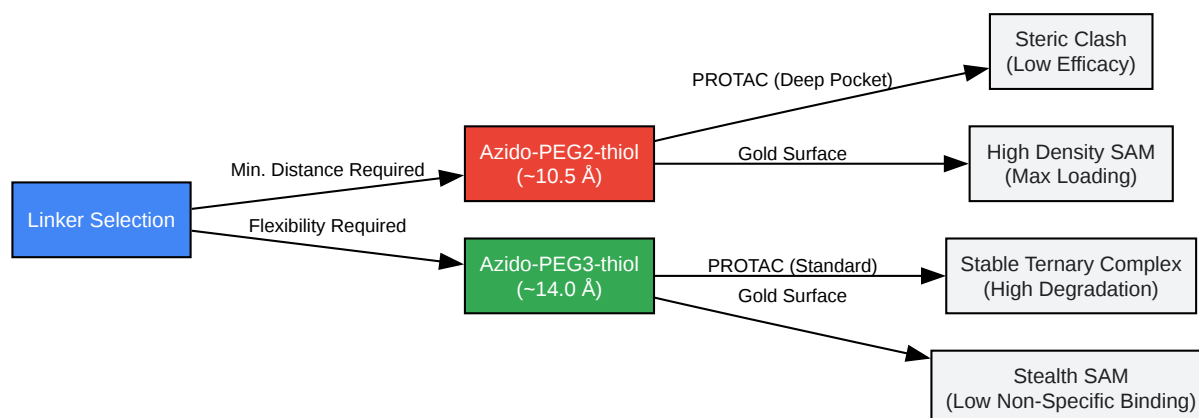

[Click to download full resolution via product page](#)

Figure 1: Decision logic for linker selection based on application constraints. PEG2 favors density; PEG3 favors flexibility and stealth.

## Experimental Protocols

### Protocol A: Dual-Functionalization of Gold Nanoparticles

Objective: Create a "clickable" gold surface using Azido-PEG-thiol.

Materials:

- Citrate-stabilized Gold Nanoparticles (AuNPs).
- Azido-PEG2-SH or Azido-PEG3-SH (10 mM stock in dry DMSO).
- Reaction Buffer: 10 mM Phosphate Buffer (PB), pH 7.4, 0.01% Tween-20.

Workflow:

- Preparation: Dilute AuNPs to ~1 nM concentration in PB.
- Ligand Exchange: Add Azido-PEG-SH stock to AuNPs to reach a final concentration of 10  $\mu$ M (excess).
  - Critical Step (PEG2): Incubate for 4 hours. The shorter chain kinetics are faster, but organization takes time.
  - Critical Step (PEG3): Incubate for 12 hours. Longer chains require more time to reorganize and maximize the "standing up" conformation.
- Purification: Centrifuge (speed depends on NP size) and wash 3x with PB to remove unbound linker.
- Validation: Measure Hydrodynamic Diameter (DLS). PEG3-AuNPs should show a larger diameter increase (~2-3 nm) compared to PEG2-AuNPs (~1-2 nm).

## Protocol B: Heterobifunctional Crosslinking (Protein-Drug Conjugate)

Objective: Link a Thiol-containing protein (e.g., Cysteine mutant) to an Alkyne-drug.

Workflow:

- Thiol-Maleimide/Disulfide Exchange (Step 1):
  - React Protein-SH with Azido-PEG<sub>n</sub>-Thiol (requires activation if using disulfide exchange, or use Maleimide-PEG-Azide if available. If strictly using Azido-PEG-Thiol, this step typically targets maleimide-functionalized surfaces or requires oxidative coupling).

- Correction: For Azido-PEG-Thiol specifically, the Thiol group is nucleophilic. It is best used to react with a Maleimide-functionalized protein or an Alpha-haloacetamide.
- Reaction: Mix Protein-Maleimide (50  $\mu$ M) with Azido-PEGn-Thiol (500  $\mu$ M) in PBS pH 7.2, 1h at RT.
- CuAAC Click Reaction (Step 2):
  - Add Alkyne-Drug (5 eq) + CuSO<sub>4</sub> (100  $\mu$ M) + THPTA (500  $\mu$ M) + Sodium Ascorbate (2.5 mM).
  - PEG2 Note: If the protein pocket is deep, the Azide may be buried. Efficiency will be low (<30%).
  - PEG3 Note: The extra length exposes the Azide to the solvent, typically boosting Click efficiency to >85%.

## Application Analysis: Case Studies

### Case Study 1: PROTAC Linker Optimization

A study on BRD4 degraders demonstrated that very short linkers (equivalent to PEG1-2) failed to degrade the target despite binding to it. The ternary complex could not form because the E3 ligase and BRD4 collided before the linker was fully extended. Switching to a PEG3-based linker restored degradation activity by relieving this steric strain [1, 2].

### Case Study 2: Biodistribution of Radiolabeled Peptides

In Bombesin analogs labeled with <sup>68</sup>Ga, replacing a PEG2 spacer with a PEG3 spacer resulted in lower liver uptake and higher tumor-to-background ratios. The increased hydrophilicity of the PEG3 chain facilitated renal clearance over hepatobiliary excretion, improving the imaging contrast [3].

## References

- Open Exploration Publishing. Novel approaches for the rational design of PROTAC linkers. [\[Link\]](#)

- MDPI. The Effect of Mini-PEG-Based Spacer Length on Binding and Pharmacokinetic Properties of a <sup>68</sup>Ga-Labeled NOTA-Conjugated Antagonistic Analog of Bombesin. [[Link](#)]
- Nanocs. Azide PEG Thiol Technical Data Sheet. [[Link](#)]
- To cite this document: BenchChem. [Technical Guide: Comparative Analysis of Azido-PEG2-thiol and Azido-PEG3-thiol]. BenchChem, [2026]. [Online PDF]. Available at: [<https://www.benchchem.com/product/b14075388/docs#technical-guide-comparative-analysis-of-azido-peg2-thiol-and-azido-peg3-thiol>]

---

### Disclaimer & Data Validity:

The information provided in this document is for Research Use Only (RUO) and is strictly not intended for diagnostic or therapeutic procedures. While BenchChem strives to provide accurate protocols, we make no warranties, express or implied, regarding the fitness of this product for every specific experimental setup.

**Technical Support:** The protocols provided are for reference purposes. Unsure if this reagent suits your experiment?

**Need Industrial/Bulk Grade?** [Request Custom Synthesis Quote](#)

## BenchChem

Our mission is to be the trusted global source of essential and advanced chemicals, empowering scientists and researchers to drive progress in science and industry.

### Contact

Address: 3281 E Guasti Rd  
Ontario, CA 91761, United States  
Phone: (601) 213-4426  
Email: [info@benchchem.com](mailto:info@benchchem.com)

[Contact our Ph.D. Support Team for a compatibility check](#)

