

# Comparative Bioactivity Guide: 2-Methoxy vs. 4-Methoxy Phenylalanine Derivatives

**Author:** BenchChem Technical Support Team. **Date:** May 2026

## Compound of Interest

**Compound Name:** 2-Amino-3-(2-methoxy-4-methylphenyl)propanoic acid

**CAS No.:** 1391006-50-0

**Cat. No.:** B1407206

[Get Quote](#)

## Executive Summary

In medicinal chemistry and peptide engineering, the strategic placement of a methoxy group on the phenylalanine (Phe) ring serves two distinct mechanistic functions depending on positional isomerism.

- 4-Methoxy-L-phenylalanine (4-OMe-Phe): Primarily acts as an electronic and pharmacophoric probe. It mimics Tyrosine (Tyr) but masks the hydrogen bond donor capability (OH OMe), retaining only hydrogen bond acceptor potential. It is often used to assess the necessity of the phenolic hydroxyl group in receptor binding.
- 2-Methoxy-L-phenylalanine (2-OMe-Phe): Primarily acts as a conformational lock. The ortho-substitution induces significant steric strain, restricting rotation around the  
and

bonds. This reduces the entropic penalty of binding by pre-organizing the peptide backbone and side chain into a specific bioactive conformation.

This guide compares their physicochemical properties, bioactivity profiles, and experimental considerations to assist in rational analog design.

## Chemical & Structural Basis[1][2][3][4]

The distinct behaviors of these isomers arise from the interplay between electronic effects and steric hindrance.

Feature	2-Methoxy-Phe (Ortho)	4-Methoxy-Phe (Para)	Impact on Bioactivity
Steric Bulk	High (Proximal to backbone)	Low (Distal to backbone)	2-OMe: Restricts torsion angles; shields amide bonds. 4-OMe: Extends pharmacophore length; minimal backbone impact.
Electronic Effect	(Inductive/Resonance)	(Resonance dominant)	4-OMe: Strong electron donor to the ring; increases electron density at C3/C5.
H-Bonding	Intramolecular (with backbone NH)	Intermolecular (with Receptor)	2-OMe: Can form stable 7-membered ring with backbone NH, locking conformation.
Lipophilicity			Similar bulk lipophilicity, but 2-OMe often appears more "buried" in folded structures.

## Structural Logic Diagram (SAR Decision Tree)



[Click to download full resolution via product page](#)

Figure 1: Decision tree for selecting between ortho- and para-methoxy substitutions based on SAR goals.

## Bioactivity Case Studies

## Case Study A: Opioid Receptor Binding ( -Opioid)

- Context: Endogenous opioid peptides (e.g., Endomorphins, Enkephalins) rely on Tyr and Phe aromatic rings for receptor activation.
- 4-OMe-Phe Performance: When replacing Tyr, 4-OMe-Phe typically results in a loss of affinity (10-100 fold). This confirms the critical role of the Tyrosine hydroxyl group as a hydrogen bond donor to a Histidine residue in the receptor pocket. However, as a replacement for Phe in Endomorphin-2, it is often tolerated, suggesting the distal pocket at position 4 is spacious and hydrophobic.
- 2-OMe-Phe Performance: Analogous to 2,6-dimethyltyrosine (Dmt), 2-OMe-Phe restricts the side-chain orientation. In specific cyclic opioid analogs, 2-substitution enhances affinity by locking the aromatic ring in a perpendicular orientation relative to the peptide backbone, a requirement for  $\mu$ -receptor activation.

## Case Study B: Taste Receptors (Aspartame Analogues)

- Context: Aspartame (L-Asp-L-Phe-OMe) is a high-intensity sweetener. The receptor binding pocket is sterically sensitive.
- Comparison:
  - 4-OMe-Phe: Substitution at the para position abolishes sweetness. The additional bulk extends the molecule beyond the receptor's "sweet finger" tolerance.
  - 2-OMe-Phe: Substitution at the ortho position retains sweetness. The substituent folds back towards the peptide backbone, avoiding steric clash with the receptor wall while maintaining the hydrophobic pharmacophore required for binding.

## Case Study C: Metabolic Stability

- **Proteolytic Stability:** 2-OMe-Phe confers superior stability against chymotrypsin-like proteases compared to 4-OMe-Phe. The ortho-methoxy group creates a "steric umbrella" that hinders the enzyme's catalytic triad from accessing the scissile amide bond.
- **Metabolic Liabilities:** Both are susceptible to O-demethylation by Cytochrome P450 (CYP) enzymes, generating the corresponding phenol (Tyr or o-Tyr). However, 4-OMe is generally more accessible to heme iron oxidants than the sterically shielded 2-OMe.

## Experimental Protocols

### Protocol 1: Solid Phase Peptide Synthesis (SPPS)

#### Incorporation

- **Challenge:** 2-OMe-Phe is sterically hindered. Standard coupling protocols often result in deletion sequences.
- **Recommended Workflow:**
- **Resin Swelling:** DMF, 30 min.
- **Deprotection:** 20% Piperidine/DMF (2 x 10 min).
- **Coupling (4-OMe-Phe):**
  - **Reagents:** HBTU (4 eq) / DIEA (8 eq).
  - **Time:** 45 min at Room Temp.
- **Coupling (2-OMe-Phe) - Critical Modification:**
  - **Reagents:** HATU (4 eq) / HOAt (4 eq) / TMP (Collidine, 10 eq).
  - **Rationale:** HATU is a more potent coupling agent; Collidine is a weaker base that reduces racemization risk during prolonged coupling.
  - **Time:** 2 x 60 min (Double Coupling) or microwave assisted (C, 5 min).

- Monitoring: Use Chloranil test (sensitive for secondary amines) rather than Kaiser test if coupling to Proline or N-methyl amino acids.

## Protocol 2: Comparative Metabolic Stability Assay

- Objective: Determine half-life ( ) in liver microsomes.
- Preparation: Prepare 10 mM stock of peptide in DMSO.
- Incubation:
  - Mix peptide ( final) with pooled Human Liver Microsomes (0.5 mg/mL protein) in PBS (pH 7.4).
  - Pre-incubate at C for 5 min.
- Initiation: Add NADPH-regenerating system (or 1 mM NADPH).
- Sampling: Aliquot at 0, 5, 15, 30, 60 min. Quench immediately in ice-cold Acetonitrile containing Internal Standard (e.g., Tolbutamide).
- Analysis: Centrifuge (4000g, 20 min). Analyze supernatant by LC-MS/MS.
  - Note: Monitor for M-14 peak (loss of , indicating O-demethylation) and M+16 peak (ring hydroxylation).

## Visualizations

### Mechanism of Action & Metabolic Fate

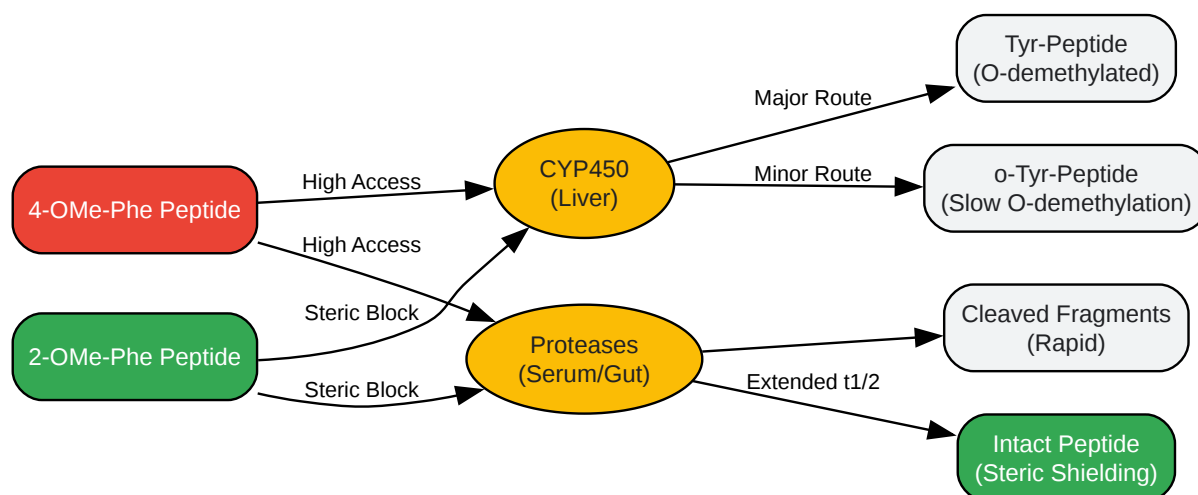

[Click to download full resolution via product page](#)

Figure 2: Comparative metabolic fate showing the steric advantage of 2-OMe-Phe against proteolysis and oxidative demethylation.

## References

- VanAlstine, M. A., et al. (2007). "Redefining the structure-activity relationships of 2,6-methano-3-benzazocines. 5. Opioid receptor binding properties." [1] ChEMBL. [Link](#)
- Shao, X., et al. (2007). [1] "Conformational analysis of endomorphin-2 analogs with phenylalanine mimics by NMR and molecular modeling." Bioorganic & Medicinal Chemistry. [Link](#)
- Iwamura, H., et al. (1980). "Peptide sweeteners. 4. Hydroxy and methoxy substitution of the aromatic ring in L-aspartyl-L-phenylalanine methyl ester. Structure-taste relationships." Journal of Medicinal Chemistry. [Link](#)
- BenchChem. (2025). "A Comparative Guide to Validating the Purity of Phe-Phe-OMe." BenchChem Technical Guides. [Link](#)
- Werder, M., et al. (1999). "Metabolic stability of peptide-based PET radiopharmaceuticals." Methods to Enhance Metabolic Stability. [Link](#)

### Need Custom Synthesis?

BenchChem offers custom synthesis for rare earth carbides and specific isotopic labeling.

Email: [info@benchchem.com](mailto:info@benchchem.com) or [Request Quote Online](#).

## Sources

- [1. Conformational analysis of endomorphin-2 analogs with phenylalanine mimics by NMR and molecular modeling - PubMed \[pubmed.ncbi.nlm.nih.gov\]](#)
- To cite this document: BenchChem. [Comparative Bioactivity Guide: 2-Methoxy vs. 4-Methoxy Phenylalanine Derivatives]. BenchChem, [2026]. [Online PDF]. Available at: [\[https://www.benchchem.com/product/b1407206/docs#comparative-bioactivity-guide-2-methoxy-vs-4-methoxy-phenylalanine-derivatives\]](https://www.benchchem.com/product/b1407206/docs#comparative-bioactivity-guide-2-methoxy-vs-4-methoxy-phenylalanine-derivatives)

### Disclaimer & Data Validity:

The information provided in this document is for Research Use Only (RUO) and is strictly not intended for diagnostic or therapeutic procedures. While BenchChem strives to provide accurate protocols, we make no warranties, express or implied, regarding the fitness of this product for every specific experimental setup.

**Technical Support:** The protocols provided are for reference purposes. Unsure if this reagent suits your experiment?

**Need Industrial/Bulk Grade?** [Request Custom Synthesis Quote](#)

## BenchChem

Our mission is to be the trusted global source of essential and advanced chemicals, empowering scientists and researchers to drive progress in science and industry.

### Contact

Address: 3281 E Guasti Rd

Ontario, CA 91761, United States

Phone: (601) 213-4426

Email: [info@benchchem.com](mailto:info@benchchem.com)

Contact our Ph.D. Support Team for a compatibility check