

# The Gatekeeper of Proliferation: Validating the Role of CTP Synthesis in Cellular Growth

**Author:** BenchChem Technical Support Team. **Date:** April 2026

## Compound of Interest

Compound Name: *Cytidine-5'-triphosphate disodium*

Cat. No.: *B14062021*

[Get Quote](#)

## A Comparative Guide to the Functions of CTP Synthase Isoforms

In the intricate landscape of cellular metabolism, the availability of nucleotide building blocks is a critical determinant of a cell's ability to grow, divide, and function. Cytidine triphosphate (CTP) is an essential precursor for the synthesis of DNA, RNA, and phospholipids.[1][2][3] Its production is tightly regulated, with the de novo synthesis pathway, which converts uridine triphosphate (UTP) to CTP, playing a central role. This conversion is catalyzed by the enzyme CTP synthase (CTPS).[1]

This guide provides an objective comparison of the key players in this pathway, focusing on the differential roles of the two human CTP synthase isoforms, CTPS1 and CTPS2. We present supporting experimental data validating the critical function of this pathway in cell proliferation and detail the methodologies used to obtain these insights. This information is crucial for researchers, scientists, and drug development professionals targeting metabolic pathways in oncology and immunology.

## The CTP De Novo Synthesis Pathway

The synthesis of CTP from UTP is the final, rate-limiting step in the de novo pyrimidine nucleotide biosynthesis pathway.[1] The reaction, catalyzed by CTP synthase, is an ATP-

dependent amination of UTP, using glutamine as the nitrogen source.[2][4] This process is fundamental for maintaining the cellular pool of CTP required for nucleic acid and lipid synthesis.[1][5] The activity of CTPS is subject to allosteric regulation, including feedback inhibition by its product, CTP, and activation by GTP.[6][7]

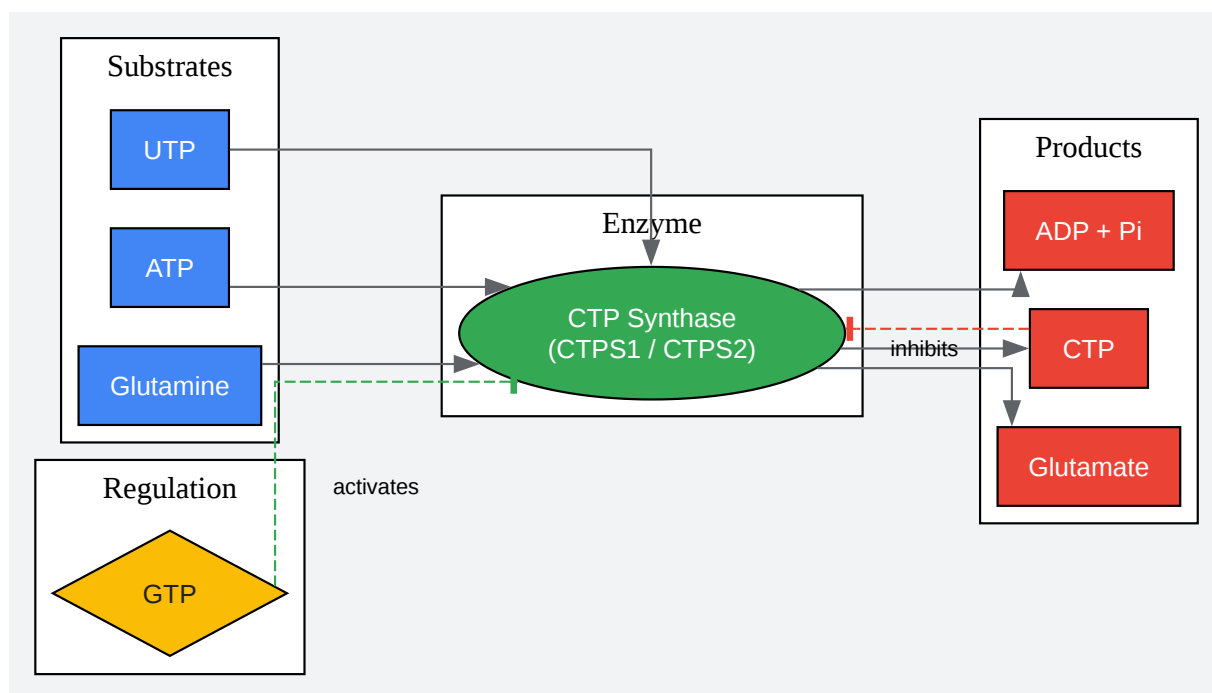

[Click to download full resolution via product page](#)

Caption: De novo synthesis of CTP from UTP by CTP Synthase.

## Performance Comparison: CTPS1 vs. CTPS2 in Cell Proliferation

While both CTPS1 and CTPS2 catalyze the same reaction, recent evidence has demonstrated their non-redundant roles in cellular proliferation.[4] Studies utilizing CRISPR/Cas9-mediated gene inactivation in various cell lines have shown that CTPS1 is the primary contributor to maintaining the CTP pool necessary for rapid cell division.[4][8] In many cancer cell lines, the loss of CTPS1 severely impairs proliferation, whereas the loss of CTPS2 has a modest effect, only becoming essential in the absence of CTPS1.[4][9]

This disparity is attributed to the higher intrinsic enzymatic activity of CTPS1 and its greater resistance to certain inhibitors compared to CTPS2.[8] These findings position CTPS1 as a high-value target for therapeutic intervention in diseases characterized by uncontrolled cell growth.

## Quantitative Data Summary: Proliferation of CTPS-Deficient HEK Cells

The following table summarizes experimental data from studies on Human Embryonic Kidney (HEK) cells where CTPS1 and/or CTPS2 were inactivated. Proliferation was measured over several days, and the relative growth rates highlight the differential importance of the two isoforms.

Cell Line Genotype	Relative Proliferation Rate (% of Wild Type)	Sensitivity to 3-Deaza-uridine (UTP Analog Inhibitor)	Key Finding
Wild Type (WT)	100%	Baseline	Normal proliferation dependent on both CTPS isoforms.
CTPS1 Knockout (CTPS1-KO)	~25%	Increased Sensitivity	Proliferation is severely impaired, demonstrating CTPS1's critical role. [4][8]
CTPS2 Knockout (CTPS2-KO)	~90%	Baseline Sensitivity	Proliferation is only slightly affected, indicating a minor role when CTPS1 is present.[4]
Double Knockout (CTPS1/2-KO)	<5%	N/A (Non-proliferative)	Complete cessation of proliferation, confirming the necessity of de novo CTP synthesis.[4]

# Experimental Protocols: Validation of CTPS Isoform Roles

To validate the differential roles of CTPS1 and CTPS2, a combination of gene editing, protein analysis, and cell-based assays is employed. Below is a detailed methodology for a key experiment.

## Protocol: Cell Proliferation Assay Post-CRISPR/Cas9-Mediated CTPS Knockout

Objective: To determine the respective contributions of CTPS1 and CTPS2 to cell proliferation.

Materials:

- HEK or Jurkat cell lines
- Lentiviral vectors containing Cas9 and guide RNAs (gRNAs) specific for CTPS1 and CTPS2
- Culture medium (e.g., DMEM/RPMI), fetal bovine serum (FBS), antibiotics
- Antibodies for Western Blot: anti-CTPS1, anti-CTPS2, anti-Actin (loading control)
- Cell counting solution (e.g., Trypan Blue) and hemocytometer or automated cell counter
- Multi-well culture plates

Methodology:

- Gene Inactivation:
  - Transduce wild-type cells with lentiviral particles carrying Cas9 and gRNAs targeting either CTPS1, CTPS2, or both. A non-targeting gRNA is used as a control.
  - Select for successfully transduced cells using an appropriate marker (e.g., puromycin).
  - Isolate single-cell clones to establish stable knockout cell lines.
- Verification of Knockout:

- Lyse cells from each clonal line to extract total protein.
- Perform Western Blot analysis using specific antibodies against CTPS1 and CTPS2 to confirm the absence of the target protein. An actin blot is used to ensure equal protein loading.
- Proliferation Assay:
  - Seed an equal number of cells (e.g.,  $5 \times 10^4$  cells/well) from each verified cell line (WT, CTPS1-KO, CTPS2-KO, Double-KO) into multiple wells of several 24-well plates.
  - At set time points (e.g., Day 0, 2, 4, 6), trypsinize and harvest the cells from one plate.
  - Count the number of viable cells in each well using a hemocytometer or an automated cell counter.
- Data Analysis:
  - For each cell line, plot the average cell number against time to generate growth curves.
  - Calculate the proliferation rate for each knockout line relative to the wild-type control.

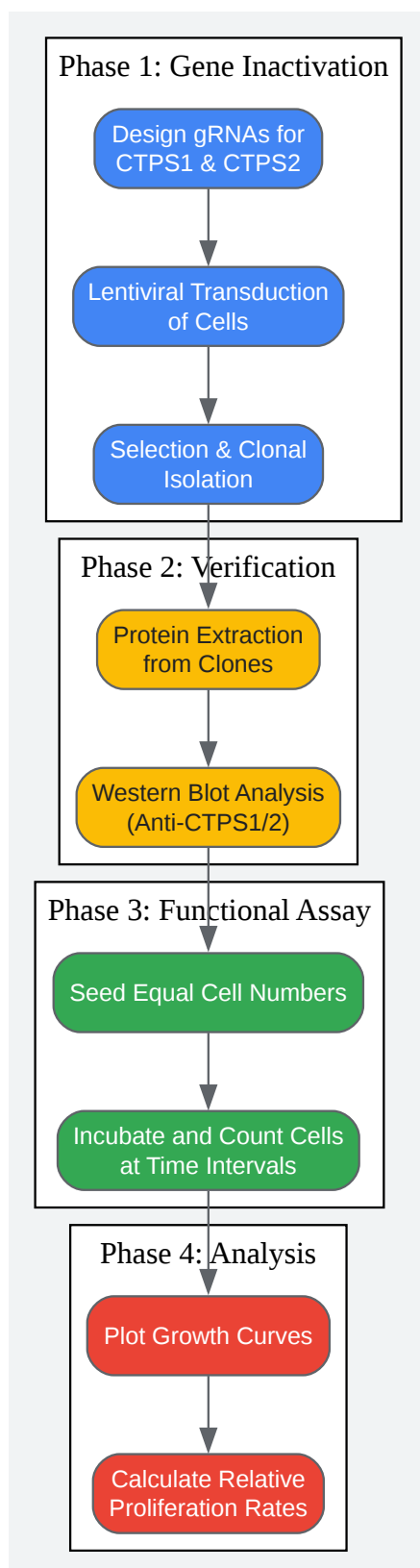

[Click to download full resolution via product page](#)

Caption: Workflow for validating the roles of CTPS isoforms.

### Need Custom Synthesis?

BenchChem offers custom synthesis for rare earth carbides and specific isotopic labeling.

Email: [info@benchchem.com](mailto:info@benchchem.com) or [Request Quote Online](#).

## References

- [1. CTP synthase: the hissing of the cellular serpent - PMC \[pmc.ncbi.nlm.nih.gov\]](#)
- [2. sinobiological.com \[sinobiological.com\]](#)
- [3. Triphosphates: Structure, Function & Synthesis explained \[baseclick.eu\]](#)
- [4. Differential roles of CTP synthetases CTPS1 and CTPS2 in cell proliferation - PMC \[pmc.ncbi.nlm.nih.gov\]](#)
- [5. The advantage of channeling nucleotides for very processive functions - PMC \[pmc.ncbi.nlm.nih.gov\]](#)
- [6. mdpi.com \[mdpi.com\]](#)
- [7. Common regulatory control of CTP synthase enzyme activity and filament formation - PMC \[pmc.ncbi.nlm.nih.gov\]](#)
- [8. researchgate.net \[researchgate.net\]](#)
- [9. Differential roles of CTP synthetases CTPS1 and CTPS2 in cell proliferation | Life Science Alliance \[life-science-alliance.org\]](#)
- To cite this document: BenchChem. [The Gatekeeper of Proliferation: Validating the Role of CTP Synthesis in Cellular Growth]. BenchChem, [2026]. [Online PDF]. Available at: [\[https://www.benchchem.com/product/b14062021/docs#the-gatekeeper-of-proliferation-validating-the-role-of-ctp-synthesis-in-cellular-growth\]](https://www.benchchem.com/product/b14062021/docs#the-gatekeeper-of-proliferation-validating-the-role-of-ctp-synthesis-in-cellular-growth)

---

### Disclaimer & Data Validity:

The information provided in this document is for Research Use Only (RUO) and is strictly not intended for diagnostic or therapeutic procedures. While BenchChem strives to provide accurate protocols, we make no warranties, express or implied, regarding the fitness of this product for every specific experimental setup.

**Technical Support:** The protocols provided are for reference purposes. Unsure if this reagent suits your experiment?

**Need Industrial/Bulk Grade?** [Request Custom Synthesis Quote](#)

## BenchChem

Our mission is to be the trusted global source of essential and advanced chemicals, empowering scientists and researchers to drive progress in science and industry.

### Contact

Address: 3281 E Guasti Rd  
Ontario, CA 91761, United States  
Phone: (601) 213-4426  
Email: [info@benchchem.com](mailto:info@benchchem.com)

[Contact our Ph.D. Support Team for a compatibility check](#)