

# Mass spectrometry fragmentation patterns of fluorinated iodoethers

**Author:** BenchChem Technical Support Team. **Date:** April 2026

## Compound of Interest

Compound Name: *1,4-Diiodo-2-ethoxy-5-fluorobenzene*

Cat. No.: *B14059322*

[Get Quote](#)

Comparative Guide: Mass Spectrometry Fragmentation Dynamics of Fluorinated Iodoethers

## Executive Summary

Fluorinated iodoethers represent a specialized class of halogenated organic compounds often utilized as intermediates in fluoropolymer synthesis and as contrast agents in medical imaging. Their analysis presents a unique dichotomy: the high electronegativity of fluorine stabilizes the carbon backbone, while the polarizable iodine atom introduces a "weak link" susceptible to rapid cleavage.

This guide provides an objective, technical comparison of the fragmentation dynamics of fluorinated iodoethers against their non-fluorinated analogs. It contrasts Hard Ionization (Electron Impact - EI) with Soft Ionization (Negative Chemical Ionization - NCI), establishing NCI as the superior modality for trace quantification due to the high electron capture cross-section of the iodine moiety.

## Mechanistic Analysis: The Chemistry of Fragmentation

To interpret the mass spectra of fluorinated iodoethers, one must understand the competition between the stability of the perfluoroalkyl chain and the lability of the carbon-iodine (C-I) bond.

## The "Weak Link" Hypothesis (C-I Cleavage)

In both fluorinated and non-fluorinated iodoethers, the C-I bond is thermodynamically the weakest.

- **Non-Fluorinated Analogs:** In standard aliphatic iodoethers, the C-I bond energy (~53 kcal/mol) is lower than C-C or C-O bonds. However, alpha-cleavage adjacent to the ether oxygen is a competitive pathway, often yielding stable oxonium ions.
- **Fluorinated Iodoethers:** The presence of fluorine atoms exerts a strong inductive effect ( $\sigma$ -I) forming a  $M^{\bullet+}$  formed during EI. The C-I bond cleaves almost instantaneously, often rendering the molecular ion invisible.

## The Fluorine Effect: Suppression of Alpha-Cleavage

In hydrogenated ethers, the dominant fragmentation is alpha-cleavage:

In perfluorinated iodoethers (

), the fluorine atoms on the alpha-carbon are highly electronegative, destabilizing the potential oxonium double bond character. Consequently, alpha-cleavage is significantly suppressed. Instead, the spectrum is dominated by perfluoroalkyl cations (

) formed after the loss of iodine.

## Comparative Analysis: EI vs. NCI

The choice of ionization technique radically alters the limit of detection (LOD) and structural information obtained.

## Table 1: Ionization Mode Comparison for Fluorinated Iodoethers

Feature	Electron Ionization (EI, 70 eV)	Negative Chemical Ionization (NCI)
Primary Mechanism	High-energy electron bombardment (Hard)	Resonance Electron Capture (Soft)
Molecular Ion ( )	Rare/Absent. Rapid loss of leads to base peaks.	Strong. Formation of or dissociative attachment yielding .
Base Peak	69 ( ) or 119 ( )	127 ( ) or Molecular Anion
Sensitivity	Moderate (ng range). Noise from background hydrocarbons.	Superior (fg to pg range). High selectivity for Halogens.
Structural Insight	Fingerprinting the perfluoroalkyl chain length.	Confirmation of Iodine presence and Molecular Weight.
Key Limitation	indistinguishable from non-iodinated fluorocarbons if is lost.	Requires a reagent gas (Methane/Ammonia) and clean source.

## Diagnostic Pathway Visualization

The following diagram illustrates the divergent pathways between standard EI fragmentation and the resonance electron capture observed in NCI.

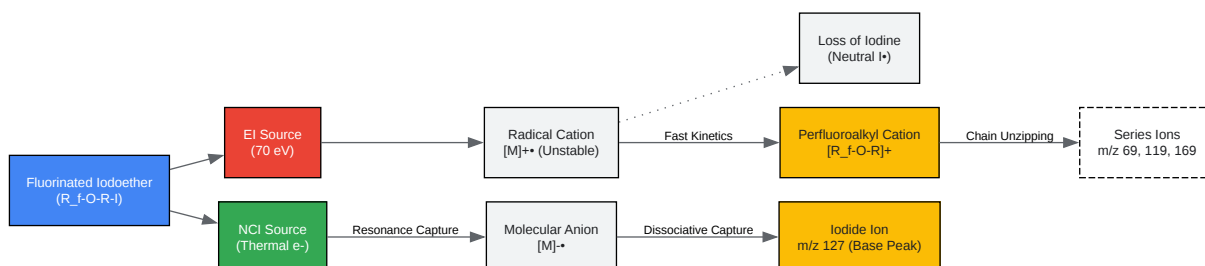

[Click to download full resolution via product page](#)

Caption: Divergent fragmentation pathways. EI favors rapid iodine loss and chain fragmentation; NCI favors iodide ion formation.

## Validated Experimental Protocol

To ensure reproducibility, we recommend a Headspace Solid-Phase Microextraction (HS-SPME) coupled with GC-MS. This method minimizes solvent interference and capitalizes on the volatility of iodoethers.

### Protocol: HS-SPME-GC-MS/NCI

Reagents & Standards:

- Internal Standard: Perfluorooctyl iodide (PFOI) or mass-labeled equivalent.
- Reagent Gas: Methane (99.999% purity) for NCI.

Step-by-Step Workflow:

- Sample Preparation:
  - Aliquot 5 mL of aqueous sample (or dissolved solid) into a 20 mL headspace vial.
  - Add 2 g NaCl (salting out effect increases volatility).

- Seal with a magnetic screw cap with PTFE/silicone septum.
- SPME Extraction:
  - Fiber Selection: 85  $\mu\text{m}$  Polyacrylate (PA) or DVB/CAR/PDMS fiber. Rationale: PA is robust for polar ethers; DVB/CAR/PDMS covers a wider volatility range.
  - Incubation: 10 min at 50°C (agitation at 500 rpm).
  - Extraction: Expose fiber to headspace for 20 min at 50°C.
- GC Configuration (Agilent 7890B or similar):
  - Column: DB-624 or VF-624ms (30 m  $\times$  0.25 mm  $\times$  1.4  $\mu\text{m}$ ). Rationale: Thick film is necessary to retain volatile fluorinated ethers.
  - Injector: Splitless mode, 250°C. Desorption time: 3 min.
  - Carrier Gas: Helium at 1.2 mL/min (constant flow).
  - Oven Program: 40°C (hold 2 min)  
10°C/min to 240°C (hold 5 min).
- MS Detection (NCI Mode):
  - Source Temp: 150°C. Rationale: Lower source temps favor molecular anion stability in NCI.
  - Reagent Gas Flow: 40% (Methane).
  - SIM Mode: Monitor  
127 (  
) and  
.

## Workflow Visualization

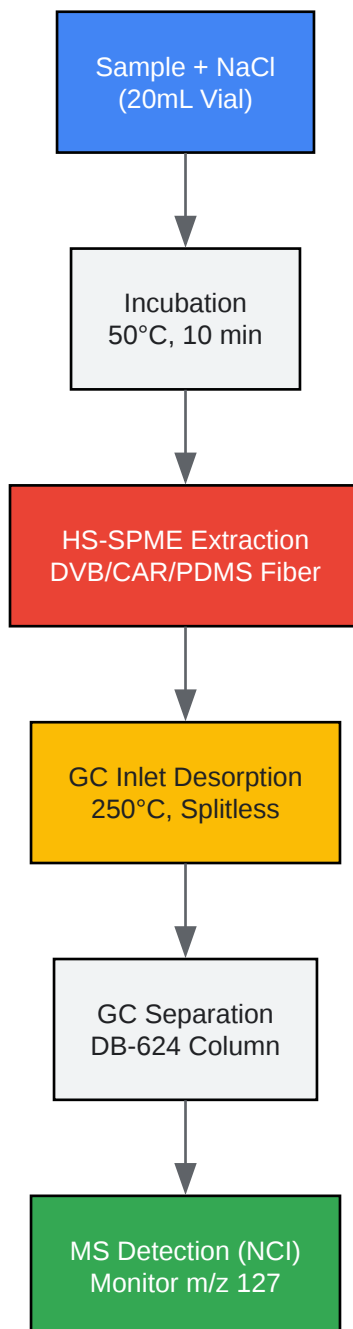

[Click to download full resolution via product page](#)

Caption: HS-SPME-GC-NCI workflow optimized for volatile fluorinated iodoethers.

## Data Interpretation & Troubleshooting

When analyzing the data, researchers often encounter "ghost peaks" or missing molecular ions.

- The "Missing Parent" in EI: If you observe a spectrum with 69, 119, 131, 169 but no high-mass peak, you are likely looking at a fluorinated compound where the iodine has already left. Check for the fragment.
- Mass Defect Analysis: Iodine has a negative mass defect (approx -0.1). Fluorine is also slightly negative. Precise mass measurement (High-Res MS) will show these compounds falling slightly below the nominal integer mass, distinguishing them from hydrocarbon impurities which have a positive mass defect.
- NCI Saturation: Because NCI is extremely sensitive to iodides, the detector may saturate easily. Ensure calibration curves cover the low pg/mL range.

## References

- Arsenault, G., et al. (2007).[1] "Analysis of perfluoroalkyl anion fragmentation pathways for perfluoroalkyl carboxylates and sulfonates." Rapid Communications in Mass Spectrometry. Available at: [\[Link\]](#)
- Bach, C., et al. (2016).[2] "Simultaneous determination of perfluoroalkyl iodides... using solid-phase microextraction-gas chromatography/mass spectrometry." Journal of Chromatography A. Available at: [\[Link\]](#)
- Riva, M., et al. (2019).[3] "Chemical ionization mass spectrometry of perfluoroalkyl substances." Atmospheric Measurement Techniques. Available at: [\[Link\]](#)
- Washington, J. W., et al. (2014).[2] "Nontargeted analysis of fluorinated telomer alcohols and iodides." Environmental Science & Technology. (Referenced via context of volatile PFAS analysis methodology in Bach et al.).

### Need Custom Synthesis?

BenchChem offers custom synthesis for rare earth carbides and specific isotopic labeling.

Email: [info@benchchem.com](mailto:info@benchchem.com) or [Request Quote Online](#).

## Sources

- 1. Analysis of perfluoroalkyl anion fragmentation pathways for perfluoroalkyl carboxylates and sulfonates during liquid chromatography/tandem mass spectrometry: evidence for fluorine migration prior to secondary and tertiary fragmentation [[pubmed.ncbi.nlm.nih.gov](https://pubmed.ncbi.nlm.nih.gov)]
- 2. [researchgate.net](https://www.researchgate.net) [[researchgate.net](https://www.researchgate.net)]
- 3. AMT - Quantification of isomer-resolved iodide chemical ionization mass spectrometry sensitivity and uncertainty using a voltage-scanning approach [[amt.copernicus.org](https://amt.copernicus.org)]
- To cite this document: BenchChem. [Mass spectrometry fragmentation patterns of fluorinated iodoethers]. BenchChem, [2026]. [Online PDF]. Available at: [<https://www.benchchem.com/product/b14059322/docs#mass-spectrometry-fragmentation-patterns-of-fluorinated-iodoethers>]

---

### Disclaimer & Data Validity:

The information provided in this document is for Research Use Only (RUO) and is strictly not intended for diagnostic or therapeutic procedures. While BenchChem strives to provide accurate protocols, we make no warranties, express or implied, regarding the fitness of this product for every specific experimental setup.

**Technical Support:** The protocols provided are for reference purposes. Unsure if this reagent suits your experiment?

**Need Industrial/Bulk Grade?** [Request Custom Synthesis Quote](#)

# BenchChem

Our mission is to be the trusted global source of essential and advanced chemicals, empowering scientists and researchers to drive progress in science and industry.

## Contact

Address: 3281 E Guasti Rd

Ontario, CA 91761, United States

Phone: (601) 213-4426

Email: [info@benchchem.com](mailto:info@benchchem.com)

[Contact our Ph.D. Support Team for a compatibility check](#)