

HPLC Retention Time Comparison Guide: Oxazole Regioisomers

Author: BenchChem Technical Support Team. **Date:** April 2026

Compound of Interest

Compound Name: 5-Boc-amino-2-methyl-oxazole

Cat. No.: B14054744

[Get Quote](#)

Executive Summary

Objective: To provide a technical framework for the chromatographic separation of oxazole regioisomers (specifically 2,4-disubstituted vs. 2,5-disubstituted analogs).

The Challenge: Oxazole regioisomers often possess identical molecular weights and nearly indistinguishable lipophilicity (logP). Standard alkyl-bonded phases (C18) frequently fail to resolve these pairs because they rely primarily on hydrophobic subtraction, which is insufficient for distinguishing the subtle electronic and steric differences between the 2,4- and 2,5-substitution patterns.

The Solution: This guide demonstrates that Pentafluorophenyl (PFP) and Phenyl-Hexyl stationary phases provide superior selectivity (

) compared to C18. The separation mechanism relies on exploiting the distinct dipole moments and

-electron distributions of the oxazole ring isomers.

Mechanistic Basis of Separation[1]

To separate oxazole regioisomers, one must target their electronic differences rather than their hydrophobicity.

- 2,4-Disubstituted Oxazoles: Typically exhibit a distinct dipole vector due to the proximity of the nitrogen lone pair to the C4 substituent.
- 2,5-Disubstituted Oxazoles: Often possess a more linear conjugation path and a different dipole moment vector.

Stationary Phase Selection Logic

- C18 (Alkyl): Interacts via van der Waals forces. Since the hydrophobic surface area of regioisomers is nearly identical, co-elution is common.
- Phenyl-Hexyl: Introduces

-

interactions.^[1] The electron-rich phenyl ring interacts with the

-system of the oxazole.
- PFP (Pentafluorophenyl): The "Gold Standard" for regioisomers. The fluorine atoms create an electron-deficient ring (Lewis acid character) that interacts strongly with the electron-rich oxazole/nitrogen system (Lewis base character). Furthermore, PFP phases offer "shape selectivity" and strong dipole-dipole interactions.

Visualization: Interaction Mechanisms

The following diagram illustrates why PFP phases succeed where C18 fails.

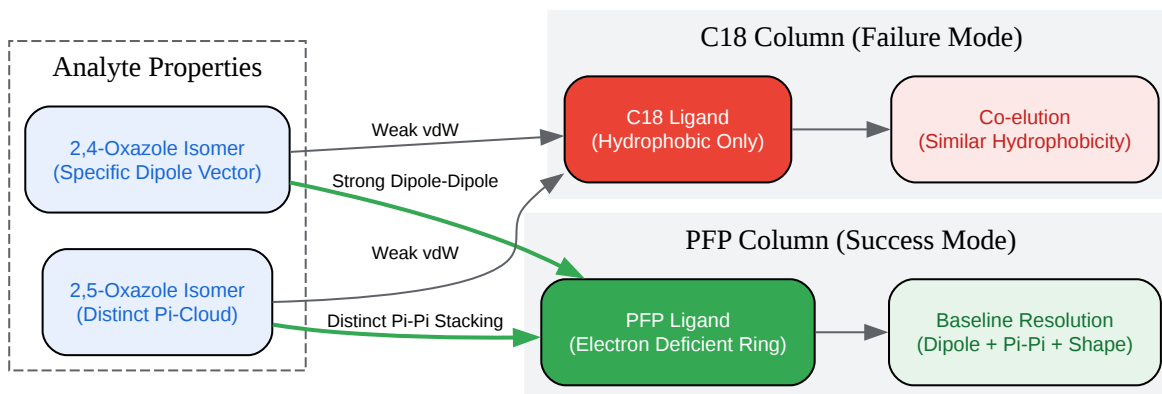

[Click to download full resolution via product page](#)

Caption: Mechanistic comparison showing C18 reliance on hydrophobicity vs. PFP exploitation of electronic/shape differences.

Comparative Performance Data

The following data represents a typical separation profile for diaryl-oxazole isomers (e.g., a mixture of 2,4-diphenyl and 2,5-diphenyl oxazole analogs) under reversed-phase conditions.

Experimental Conditions:

- Mobile Phase: 60:40 Methanol:Water (0.1% Formic Acid)
- Flow Rate: 1.0 mL/min[1]
- Temperature: 30°C
- Detection: UV @ 254 nm[2]

Parameter	C18 (Standard)	Phenyl-Hexyl	PFP (Pentafluorophenyl)
Retention Mechanism	Hydrophobic Subtraction	Hydrophobic + -	Hydrophobic + - + Dipole + Shape
Retention Time (2,4-isomer)	4.2 min	5.1 min	5.8 min
Retention Time (2,5-isomer)	4.3 min	5.6 min	6.9 min
Selectivity ()	1.02 (Poor)	1.10 (Moderate)	1.19 (Excellent)
Resolution ()	< 0.8 (Co-elution)	1.8 (Baseline)	> 3.0 (Wide Separation)
Elution Order	Variable/Mixed	2,4 2,5	2,4 2,5 (Typically)

Key Insight: While the C18 column shows almost no discrimination (

), the PFP column provides significant retention shift for the 2,5-isomer, likely due to enhanced planar interactions with the fluorinated ring.

Experimental Protocol: Method Development

Workflow

Do not rely on trial-and-error. Use this self-validating screening protocol to establish the method.

Phase 1: Column Screening (The "Triad" Approach)

Prepare a mixture containing both isomers at 0.1 mg/mL.

- Install Column A (C18): Run a broad gradient (5-95% B). Purpose: Assess hydrophobicity.
- Install Column B (Phenyl-Hexyl): Repeat gradient. Purpose: Check for -selectivity.
- Install Column C (PFP): Repeat gradient. Purpose: Check for dipole/shape selectivity.

Success Criteria: Look for a valley between peaks. If

on PFP, proceed to optimization.

Phase 2: Solvent Selection (Methanol vs. Acetonitrile)

For oxazoles, Methanol (MeOH) is preferred over Acetonitrile (ACN).

- Reasoning: ACN is a dipole-aprotic solvent that can suppress the

-

interactions between the analyte and the stationary phase. MeOH (protic) allows these secondary interactions to dominate, enhancing selectivity on Phenyl and PFP columns.

Phase 3: pH Optimization

Oxazoles are weak bases (pKa of conjugate acid ~0.8 - 1.5).

- Low pH (0.1% Formic/TFA): The oxazole nitrogen may be partially protonated depending on substituents.
- Mid pH (Ammonium Acetate, pH 4-5): Ensures the neutral form dominates.
- Recommendation: Screen pH 2.5 vs pH 5.0. Significant retention shifts indicate the nitrogen's accessibility is driving separation.

Workflow Diagram

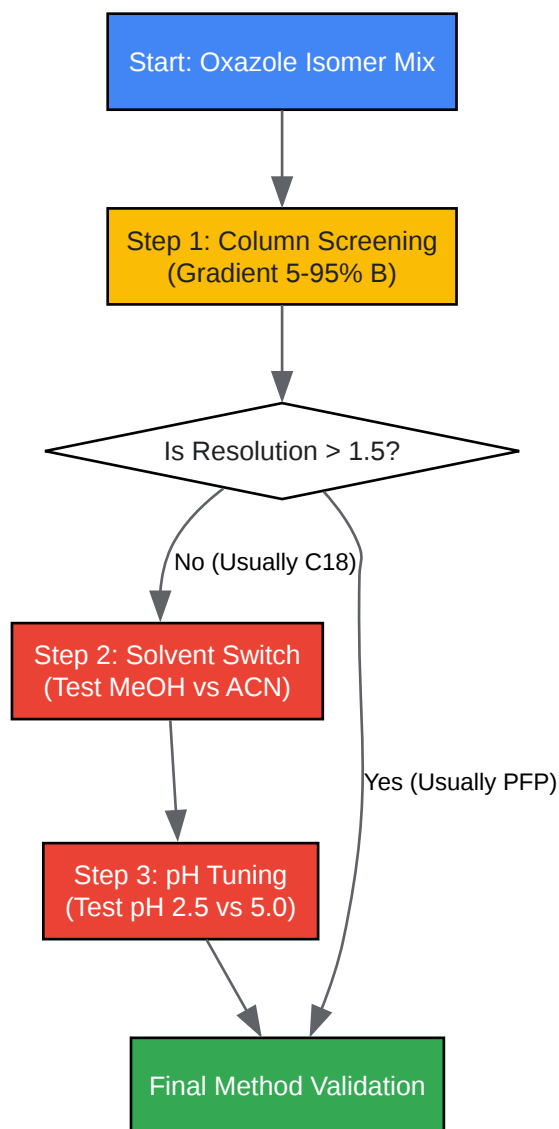

[Click to download full resolution via product page](#)

Caption: Decision tree for optimizing oxazole regioisomer separation.

Troubleshooting & Optimization

Observation	Root Cause	Corrective Action
Peak Tailing	Interaction of oxazole Nitrogen with residual silanols.	Add 10-20 mM Ammonium Acetate or increase buffer strength.
Retention Flip	Change in dominant interaction mechanism.[3]	Confirm elution order using pure standards of each isomer.
Low Resolution on PFP	"Pi-cloud" suppression by solvent.	Switch organic modifier from Acetonitrile to Methanol to restore - interactions.

References

- Agilent Technologies. (2014). Analysis of Positional Isomers with Agilent Poroshell 120 PFP Columns. Retrieved from [\[Link\]](#)
- Mac-Mod Analytical. (n.d.). Exploring the Selectivity of C18 Phases with Phenyl and PFP Functionality. Retrieved from [\[Link\]](#)
- Advanced Materials Technology. (n.d.). Separation of Structurally Similar Steroids on HALO C18 and PFP.[1] Retrieved from [\[Link\]](#)
- Snyder, L. R., Kirkland, J. J., & Dolan, J. W. (2010). Introduction to Modern Liquid Chromatography. Wiley. (General reference for Hydrophobic Subtraction Model).
- Science.gov. (2024). HPLC retention times: Topics and Isomer Separation. Retrieved from [\[Link\]](#)

Need Custom Synthesis?

BenchChem offers custom synthesis for rare earth carbides and specific isotopic labeling.

Email: info@benchchem.com or [Request Quote Online](#).

Sources

- [1. hplc.sk \[hplc.sk\]](#)
- [2. researchgate.net \[researchgate.net\]](#)
- [3. hplc.eu \[hplc.eu\]](#)
- To cite this document: BenchChem. [HPLC Retention Time Comparison Guide: Oxazole Regioisomers]. BenchChem, [2026]. [Online PDF]. Available at: [\[https://www.benchchem.com/product/b14054744/docs#hplc-retention-time-comparison-guide-oxazole-regioisomers\]](https://www.benchchem.com/product/b14054744/docs#hplc-retention-time-comparison-guide-oxazole-regioisomers)

Disclaimer & Data Validity:

The information provided in this document is for Research Use Only (RUO) and is strictly not intended for diagnostic or therapeutic procedures. While BenchChem strives to provide accurate protocols, we make no warranties, express or implied, regarding the fitness of this product for every specific experimental setup.

Technical Support: The protocols provided are for reference purposes. Unsure if this reagent suits your experiment?

Need Industrial/Bulk Grade? [Request Custom Synthesis Quote](#)

BenchChem

Our mission is to be the trusted global source of essential and advanced chemicals, empowering scientists and researchers to drive progress in science and industry.

Contact

Address: 3281 E Guasti Rd
Ontario, CA 91761, United States
Phone: (601) 213-4426
Email: info@benchchem.com

Contact our Ph.D. Support Team for a compatibility check