

Using 9-Azido-1-nonanol for microarray fabrication

Author: BenchChem Technical Support Team. **Date:** May 2026

Compound of Interest

Compound Name: 9-Azido-1-nonanol

CAS No.: 57395-47-8

Cat. No.: B1405113

[Get Quote](#)

Application Note: High-Fidelity Microarray Fabrication using **9-Azido-1-nonanol**

Executive Summary

This guide details the protocol for utilizing **9-Azido-1-nonanol** as a heterobifunctional linker for microarray fabrication. Unlike short-chain azides, the 9-carbon alkyl chain of **9-Azido-1-nonanol** acts as a critical steric spacer, decoupling the immobilized probe from the solid substrate. This "spacer effect" significantly enhances hybridization kinetics and enzymatic accessibility.

This protocol employs a modular urethane-linkage strategy, coupling the hydroxyl group of **9-Azido-1-nonanol** to an isocyanate-activated glass surface, followed by Copper-Catalyzed Azide-Alkyne Cycloaddition (CuAAC) for probe immobilization.

Scientific Rationale & Mechanism

The "Spacer Effect" in Microarrays

Direct adsorption of biomolecules to glass often results in denaturation or steric hindrance, rendering the probe inaccessible to targets.

- **Why 9-Azido-1-nonanol?** The C9 alkyl chain provides a separation distance of approximately 1.2–1.5 nm. This length is optimal—long enough to allow the probe to adopt its native conformation (Solution-Like Phase) but short enough to prevent the "mushrooming" or entanglement seen with long polymer brushes.
- **The Azide Advantage:** The terminal azide group is bio-orthogonal and chemically inert under most physiological conditions, preventing non-specific binding until the specific "Click" activation is triggered.

Surface Chemistry Workflow

The fabrication relies on two high-fidelity chemical transformations:

- **Surface Activation:** An isocyanate-silane (e.g., 3-(Triethoxysilyl)propyl isocyanate) generates a highly reactive electrophilic surface.
- **Linker Coupling:** The hydroxyl group (-OH) of **9-Azido-1-nonanol** performs a nucleophilic attack on the surface isocyanate, forming a stable urethane (carbamate) linkage.
- **Probe Immobilization:** The exposed azide tail reacts with alkyne-modified probes via CuAAC to form a 1,2,3-triazole linkage.

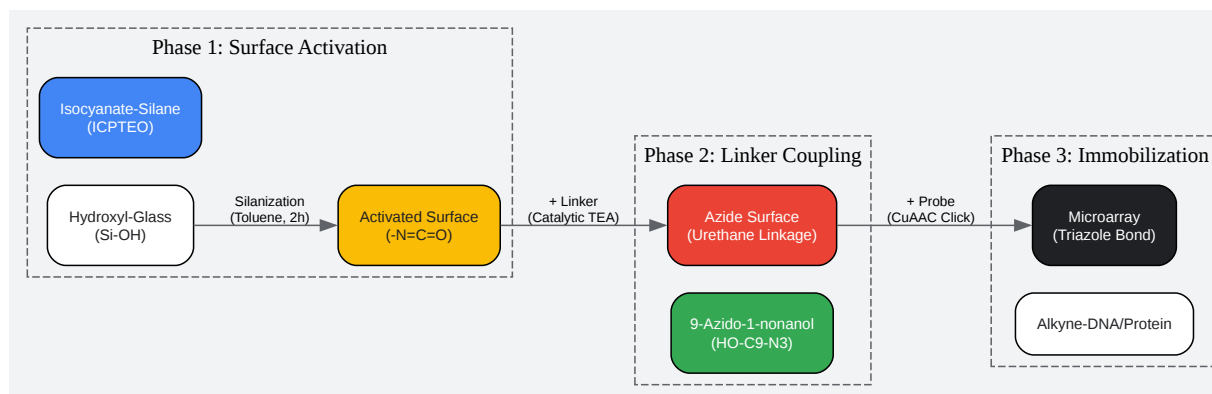

[Click to download full resolution via product page](#)

Figure 1: Step-wise chemical progression from bare glass to functional microarray.

Materials & Equipment

Component	Specification	Purpose
Linker	9-Azido-1-nonanol (>95% Purity)	Provides C9 spacer and Azide handle.
Silane	3-(Triethoxysilyl)propyl isocyanate (ICPTEO)	Generates reactive surface for alcohol binding.
Catalyst	Triethylamine (TEA) or Dibutyltin dilaurate (DBTDL)	Catalyzes urethane bond formation.
Solvent A	Anhydrous Toluene	Silanization solvent (moisture-free).
Solvent B	Anhydrous Acetonitrile (MeCN) or DMF	Linker coupling solvent.
Click Reagents	CuSO ₄ · 5H ₂ O, Sodium Ascorbate, THPTA Ligand	Catalyzes the Azide-Alkyne cycloaddition.
Substrate	Borosilicate Glass Slides	Low-fluorescence background support.

Detailed Protocol

Phase 1: Surface Activation (Silanization)

Goal: Create a dense monolayer of isocyanate groups.

- **Cleaning:** Immerse glass slides in Piranha solution (3:1 H₂SO₄:H₂O₂) for 30 minutes. Caution: Exothermic. Rinse extensively with Milli-Q water and dry under N₂ stream.
- **Plasma Treatment:** Treat slides with Oxygen Plasma (100W, 2 min) to maximize surface hydroxyl density.
- **Silanization:**
 - Prepare a 2% (v/v) solution of 3-(Triethoxysilyl)propyl isocyanate in anhydrous Toluene.
 - Incubate slides in the solution for 4 hours at room temperature (or 1 hour at 50°C) in a moisture-controlled chamber.

- Note: Moisture causes polymerization of the silane in solution. Use a glovebox or sealed jar.
- Washing: Rinse slides sequentially with Toluene (x2) and Ethanol (x2) to remove unbound silane. Cure at 110°C for 15 minutes to crosslink the silane layer.

Phase 2: Linker Coupling (Installing 9-Azido-1-nonanol)

Goal: React the alcohol tail of the linker with the surface isocyanate.

- Reaction Mix: Prepare a 50 mM solution of **9-Azido-1-nonanol** in anhydrous Acetonitrile (MeCN). Add 1% (v/v) Triethylamine (TEA) as a base catalyst.
- Coupling: Immerse the isocyanate-activated slides into the reaction mix.
 - Incubate for 12–16 hours at Room Temperature.
 - Mechanism Check: The TEA deprotonates the alcohol slightly, enhancing nucleophilic attack on the isocyanate carbon.
- Blocking (Optional but Recommended): Add 10 mM Ethanolamine to the solution for the final 30 minutes to quench any remaining unreacted isocyanate groups (prevents non-specific binding later).
- Washing: Rinse with MeCN, then Ethanol, then Water. Dry under N₂.
 - QC Point: Measure Contact Angle. A successful C9-Azide layer should show a contact angle of ~65–75° (moderately hydrophobic).

Phase 3: Probe Immobilization (CuAAC "Click")

Goal: Covalently attach alkyne-modified probes.

- Probe Preparation: Dissolve Alkyne-modified DNA/Protein in 1x PBS (pH 7.4). Typical concentration: 10–50 μM.
- Catalyst Mix (Freshly Prepared):
 - Mix CuSO₄ (1 mM final) + THPTA Ligand (2 mM final).

- Add Sodium Ascorbate (5 mM final) immediately before use.
- Spotting:
 - Pre-mix the Probe solution with the Catalyst Mix (1:1 ratio).
 - Spot onto the Azide-functionalized slide using a microarray printer (piezo or pin).
- Incubation: Incubate in a humid chamber for 1–2 hours at Room Temperature (DNA) or 4°C (Proteins).
- Post-Print Wash: Wash vigorously with PBS + 0.1% Tween-20, followed by 10 mM EDTA (to strip copper ions), then Milli-Q water.

Quality Control & Troubleshooting

Parameter	Method	Acceptance Criteria	Troubleshooting
Surface Homogeneity	Water Contact Angle	$70^{\circ} \pm 5^{\circ}$	<50°: Failed silanization. Re-clean slides and check Toluene dryness.
Azide Functionalization	IR Spectroscopy (ATR-FTIR)	Peak at $\sim 2100 \text{ cm}^{-1}$ (Azide stretch)	No peak: Linker coupling failed. Ensure TEA catalyst was used.
Spot Morphology	Fluorescence Scanner	Circular, uniform spots	"Donut" shapes: Drying too fast. Add glycerol to spotting buffer.
Background Noise	Fluorescence Scanner	< 500 RFU	High BG: Incomplete washing of Copper. Increase EDTA wash steps.

Application Notes & Advantages

- **Small Molecule Screening:** The **9-Azido-1-nonanol** surface is ideal for "Fragment-Based Drug Discovery" (FBDD) arrays where small alkyne-fragments are immobilized. The C9 spacer prevents the glass surface from interfering with the drug-protein binding interface.
- **Stability:** The urethane linkage is chemically stable at neutral/basic pH, unlike ester linkages which can hydrolyze over time.
- **Bio-orthogonality:** Unlike Epoxy/Aldehyde slides which react with any amine (random orientation), the Azide surface reacts only with the Alkyne tag, ensuring 100% oriented display of the probe.

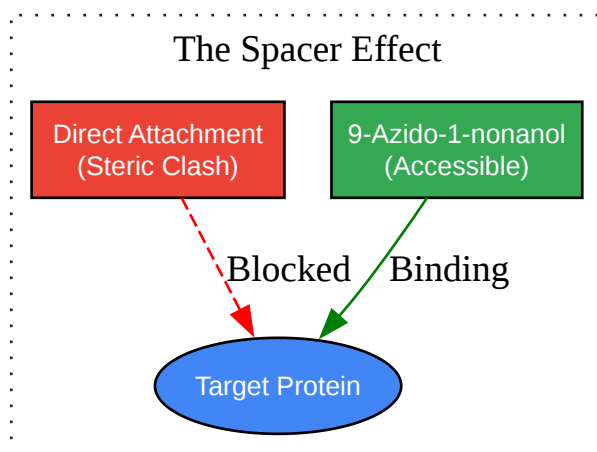

[Click to download full resolution via product page](#)

Figure 2: Schematic comparison of steric accessibility provided by the C9 spacer.

References

- Rostovtsev, V. V., et al. (2002). A Stepwise Huisgen Cycloaddition Process: Copper(I)-Catalyzed Regioselective "Ligation" of Azides and Terminal Alkynes. *Angewandte Chemie International Edition*. [Link](#)
- Nandivada, H., et al. (2007). Reactive polymer coatings that 'click'.^{[1][2]} *Angewandte Chemie*. [Link](#)

- Goddard, J. M., & Hotchkiss, J. H. (2007). Polymer surface modification for the attachment of bioactive compounds.[1][3] Progress in Polymer Science. [Link](#)
- Love, J. C., et al. (2005). Self-Assembled Monolayers of Thiolates on Metals as a Form of Nanotechnology. Chemical Reviews. (Reference for spacer chain ordering physics). [Link](#)
- Thermo Fisher Scientific. Click Chemistry Labeling & Detection. (General Protocol Guidance). [Link](#)

Need Custom Synthesis?

BenchChem offers custom synthesis for rare earth carbides and specific isotopic labeling.

Email: info@benchchem.com or [Request Quote Online](#).

Sources

- 1. magnet.engr.uga.edu [magnet.engr.uga.edu]
- 2. researchgate.net [researchgate.net]
- 3. researchgate.net [researchgate.net]
- To cite this document: BenchChem. [Using 9-Azido-1-nonanol for microarray fabrication]. BenchChem, [2026]. [Online PDF]. Available at: [<https://www.benchchem.com/product/b1405113/docs#using-9-azido-1-nonanol-for-microarray-fabrication>]

Disclaimer & Data Validity:

The information provided in this document is for Research Use Only (RUO) and is strictly not intended for diagnostic or therapeutic procedures. While BenchChem strives to provide accurate protocols, we make no warranties, express or implied, regarding the fitness of this product for every specific experimental setup.

Technical Support: The protocols provided are for reference purposes. Unsure if this reagent suits your experiment?

Need Industrial/Bulk Grade? [Request Custom Synthesis Quote](#)

BenchChem

Our mission is to be the trusted global source of essential and advanced chemicals, empowering scientists and researchers to drive progress in science and industry.

Contact

Address: 3281 E Guasti Rd

Ontario, CA 91761, United States

Phone: (601) 213-4426

Email: info@benchchem.com

[Contact our Ph.D. Support Team for a compatibility check](#)