

Application Notes and Protocols for Fluorinated Building Blocks in Organic Electronics

Author: BenchChem Technical Support Team. **Date:** May 2026

Compound of Interest

Compound Name: *2-Fluoro-5-methoxy-3-(trifluoromethyl)benzonitrile*

CAS No.: 1373920-99-0

Cat. No.: B1405346

[Get Quote](#)

Introduction: The Transformative Impact of Fluorination in Organic Electronics

The strategic incorporation of fluorine atoms into organic semiconducting materials represents one of the most significant advancements in the field of organic electronics. Due to its high electronegativity, small atomic radius, and the strength of the carbon-fluorine (C-F) bond, fluorine imparts a unique set of properties to conjugated molecules and polymers.[1][2] These properties are not merely incremental improvements but often lead to transformative enhancements in device performance, stability, and processability. This guide provides an in-depth exploration of fluorinated building blocks, offering both foundational insights and detailed, field-proven protocols for their synthesis, characterization, and application in various organic electronic devices.

Fluorination is a powerful strategy for the chemical and functional modification of materials, as the introduction of fluorine atoms can alter the physical, chemical, and electronic properties of a material, leading to improved key characteristics.[1][3] The primary effects of fluorination on organic semiconductors include the lowering of both the Highest Occupied Molecular Orbital

(HOMO) and Lowest Unoccupied Molecular Orbital (LUMO) energy levels.[1] This modulation of frontier orbitals is crucial for optimizing charge injection and transport in devices like organic field-effect transistors (OFETs), organic photovoltaics (OPVs), and organic light-emitting diodes (OLEDs).[1] Furthermore, the introduction of fluorine can enhance intermolecular interactions, leading to improved molecular packing and crystallinity, which is beneficial for charge transport.[1] The inherent stability of the C-F bond also contributes to the enhanced operational and environmental stability of the resulting devices.[4]

This document is structured to guide researchers, from material synthesis to device characterization, providing the necessary knowledge to effectively utilize fluorinated building blocks in their research and development endeavors.

Part 1: Synthesis of Fluorinated Building Blocks and Polymers

The successful implementation of fluorinated materials in organic electronics begins with their synthesis. The choice of synthetic route is critical in determining the final properties of the material. This section details a robust protocol for the synthesis of a common class of fluorinated building blocks, fluorinated benzothiadiazoles, and their subsequent polymerization into high-performance donor-acceptor copolymers.

Rationale for Suzuki and Stille Coupling Reactions

Suzuki and Stille cross-coupling reactions are among the most powerful and versatile methods for the formation of carbon-carbon bonds in the synthesis of conjugated polymers.[5][6][7]

- **Suzuki Coupling:** This reaction involves the coupling of an organoboron compound (like a boronic acid or ester) with an organohalide, catalyzed by a palladium complex.[7] Its advantages include the commercial availability of a wide range of boronic acids, mild reaction conditions, and the generation of non-toxic byproducts.[7]
- **Stille Coupling:** This reaction couples an organotin compound (stannane) with an organohalide, also catalyzed by palladium.[5] It is highly tolerant of a wide variety of functional groups and is particularly effective for the synthesis of complex conjugated systems.

The choice between Suzuki and Stille coupling often depends on the specific monomers and the desired properties of the final polymer. For the synthesis of many fluorinated donor-acceptor copolymers, both methods have proven to be highly effective.

Protocol: Synthesis of a Fluorinated Benzothiadiazole-Based Copolymer via Suzuki Polycondensation

This protocol describes the synthesis of a donor-acceptor copolymer comprising a fluorene donor unit and a fluorinated benzothiadiazole acceptor unit, a common motif in high-performance organic solar cells.[\[5\]](#)

Materials:

- 2,7-bis(4,4,5,5-tetramethyl-1,3,2-dioxaborolan-2-yl)-9,9-dioctylfluorene (M1)
- 4,7-dibromo-5,6-difluorobenzothiadiazole (M2)
- Tris(dibenzylideneacetone)dipalladium(0) ($\text{Pd}_2(\text{dba})_3$)
- Tri(tert-butyl)phosphine ($\text{P}(\text{t-Bu})_3$)
- Potassium phosphate (K_3PO_4)
- Anhydrous toluene
- Anhydrous N,N-dimethylformamide (DMF)
- Methanol
- Acetone
- Hexanes
- Standard Schlenk line and glassware
- Argon or Nitrogen gas supply

Procedure:

- **Monomer and Catalyst Preparation:** In a glovebox, add M1 (1.0 mmol), M2 (1.0 mmol), Pd₂(dba)₃ (0.02 mmol), and P(t-Bu)₃ (0.08 mmol) to a Schlenk flask equipped with a magnetic stir bar.
- **Solvent and Base Addition:** Add anhydrous toluene (20 mL) and a 2M aqueous solution of K₃PO₄ (5 mL) to the flask.
- **Reaction Setup:** Seal the flask, remove it from the glovebox, and connect it to a Schlenk line under a positive pressure of argon.
- **Polymerization:** Heat the reaction mixture to 90 °C and stir vigorously for 48 hours. The solution will become viscous as the polymer forms.
- **End-capping and Precipitation:** Cool the reaction to room temperature. Add a small amount of phenylboronic acid to end-cap the polymer chains, followed by a small amount of bromobenzene. Stir for 2 hours. Precipitate the polymer by slowly adding the reaction mixture to a stirred solution of methanol (200 mL).
- **Purification:**
 - Collect the polymer by filtration.
 - Wash the polymer sequentially with methanol, acetone, and hexanes to remove oligomers and residual catalyst.
 - Further purify the polymer by Soxhlet extraction with methanol, acetone, hexanes, and finally chloroform. The purified polymer is collected from the chloroform fraction.
- **Drying:** Dry the purified polymer under vacuum at 60 °C for 24 hours.

Characterization of the Synthesized Polymer

- **Nuclear Magnetic Resonance (NMR) Spectroscopy:** Confirm the polymer structure and purity using ¹H and ¹⁹F NMR.
- **Gel Permeation Chromatography (GPC):** Determine the number-average molecular weight (M_n), weight-average molecular weight (M_w), and polydispersity index (PDI) of the polymer.

Part 2: Application in Organic Electronic Devices

Fluorinated building blocks are integral to the fabrication of high-performance OFETs, OPVs, and OLEDs. This section provides detailed protocols for the fabrication and characterization of these devices, highlighting the role of fluorinated materials.

Organic Field-Effect Transistors (OFETs)

OFETs are fundamental components of organic electronics, and their performance is highly dependent on the charge transport characteristics of the organic semiconductor. Fluorination can significantly enhance charge carrier mobility in OFETs.[\[8\]](#)

Protocol: Fabrication of a Bottom-Gate, Top-Contact OFET with a Fluorinated Polymer Semiconductor

This protocol details the fabrication of an OFET using the n-type fluorinated polymer P(NDI2OD-T2).[\[8\]](#)

Materials:

- Heavily doped Si wafer with a 300 nm SiO₂ layer (gate and gate dielectric)
- P(NDI2OD-T2) solution in chloroform (5 mg/mL)
- Gold (Au) for source and drain electrodes
- Trichloro(octadecyl)silane (OTS) for surface treatment
- Toluene, acetone, isopropanol
- Spin coater
- Thermal evaporator
- Shadow mask for electrode deposition

Procedure:

- Substrate Cleaning:

- Sonicate the Si/SiO₂ substrate sequentially in toluene, acetone, and isopropanol for 15 minutes each.
- Dry the substrate with a stream of nitrogen.
- Treat the substrate with oxygen plasma for 5 minutes to create a hydrophilic surface.
- Surface Modification:
 - Immerse the cleaned substrate in a 10 mM solution of OTS in anhydrous toluene for 30 minutes to form a self-assembled monolayer.
 - Rinse the substrate with fresh toluene and dry with nitrogen. This treatment creates a hydrophobic surface, which promotes better crystal growth of the organic semiconductor.
- Semiconductor Deposition:
 - Spin-coat the P(NDI2OD-T2) solution onto the OTS-treated substrate at 2000 rpm for 60 seconds.
 - Anneal the film at 150 °C for 30 minutes in a nitrogen-filled glovebox.
- Electrode Deposition:
 - Place a shadow mask with the desired channel length and width onto the semiconductor film.
 - Thermally evaporate 50 nm of gold through the mask to define the source and drain electrodes.
- Device Characterization:
 - Measure the output and transfer characteristics of the OFET using a semiconductor parameter analyzer in a glovebox or in air.
 - Extract key parameters such as charge carrier mobility, on/off ratio, and threshold voltage from the electrical characteristics.

Diagram: OFET Device Architecture

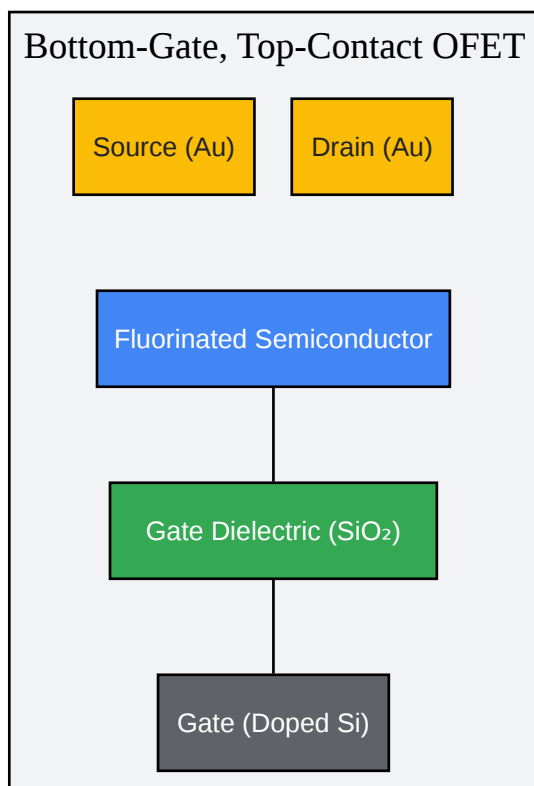

[Click to download full resolution via product page](#)

Caption: Schematic of a bottom-gate, top-contact OFET.

Organic Photovoltaics (OPVs)

In OPVs, fluorination of the donor polymer or small molecule acceptor can lead to improved power conversion efficiencies (PCE) by optimizing the energy level alignment for efficient charge separation and by enhancing the open-circuit voltage (Voc).^{[1][9]}

Protocol: Fabrication of a Bulk Heterojunction (BHJ) OPV

This protocol describes the fabrication of a conventional BHJ solar cell using the fluorinated polymer PTB7-Th as the donor and PC₇₁BM as the acceptor.^{[9][10][11][12]}

Materials:

- Patterned indium tin oxide (ITO) coated glass substrates
- Poly(3,4-ethylenedioxythiophene) polystyrene sulfonate (PEDOT:PSS) aqueous dispersion
- PTB7-Th
- PC₇₁BM
- Chlorobenzene
- 1,8-diiodoctane (DIO)
- Lithium fluoride (LiF)
- Aluminum (Al)
- Spin coater
- Thermal evaporator
- Solar simulator
- Current-voltage (I-V) measurement system

Procedure:

- Substrate Cleaning: Clean the ITO substrates following the same procedure as for OFETs.
- Hole Transport Layer (HTL) Deposition:
 - Spin-coat a filtered PEDOT:PSS solution onto the ITO substrate at 4000 rpm for 60 seconds.
 - Anneal the substrate at 150 °C for 15 minutes in air.
- Active Layer Deposition:
 - Prepare a blend solution of PTB7-Th:PC₇₁BM (1:1.5 weight ratio) in chlorobenzene with 3% v/v DIO. The total solid concentration should be around 25 mg/mL.

- Spin-coat the active layer solution onto the PEDOT:PSS layer at 1000 rpm for 60 seconds in a nitrogen-filled glovebox.
- Cathode Deposition:
 - Transfer the substrates to a thermal evaporator.
 - Deposit a 1 nm thick layer of LiF followed by a 100 nm thick layer of Al at a pressure below 10^{-6} Torr.
- Device Characterization:
 - Measure the I-V characteristics of the solar cell under simulated AM 1.5G illumination (100 mW/cm²).
 - Determine the key photovoltaic parameters: PCE, Voc, short-circuit current density (Jsc), and fill factor (FF).

Diagram: OPV Device Architecture

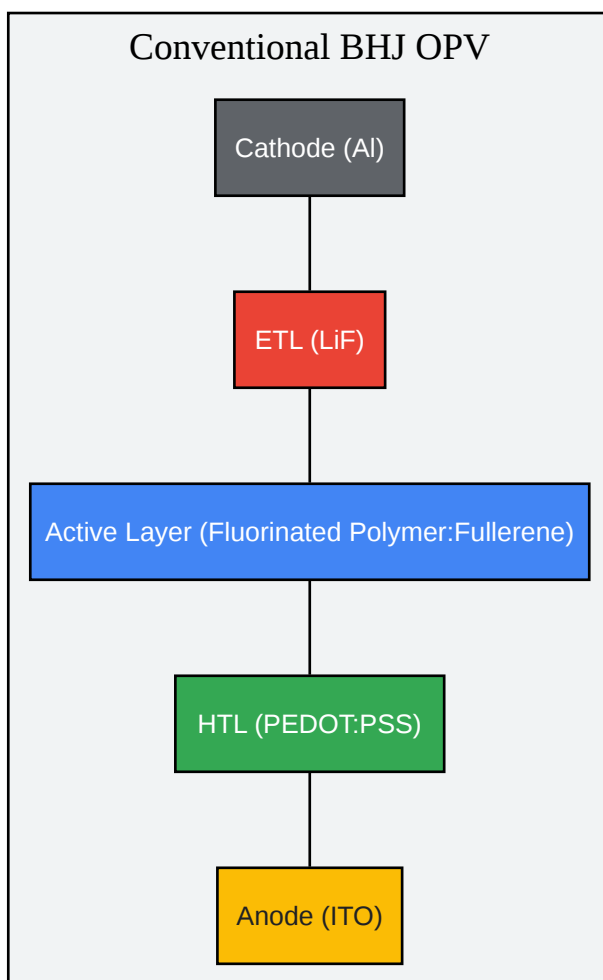

[Click to download full resolution via product page](#)

Caption: Schematic of a conventional bulk heterojunction OPV.

Organic Light-Emitting Diodes (OLEDs)

In OLEDs, fluorinated materials can be used as hosts, emitters, or charge transport materials to improve efficiency, color purity, and operational stability.[13] Fluorinated thermally activated delayed fluorescence (TADF) emitters are particularly promising for achieving high-efficiency metal-free OLEDs.[14][15][16]

Protocol: Fabrication of a Multilayer OLED with a Fluorinated TADF Emitter

This protocol outlines the fabrication of a solution-processed OLED employing a fluorinated TADF emitter.[15]

Materials:

- Patterned ITO coated glass substrates
- PEDOT:PSS
- Host material (e.g., PYD2)
- Fluorinated TADF emitter
- Electron transport layer (ETL) material (e.g., TPBi)
- Hole-blocking/exciton-blocking layer (HBL/EBL) material (e.g., DPEPO)
- Chlorobenzene
- LiF
- Al
- Spin coater
- Thermal evaporator
- Electroluminescence (EL) measurement system

Procedure:

- Substrate Cleaning and HTL Deposition: Follow steps 1 and 2 from the OPV fabrication protocol.
- Emissive Layer (EML) Deposition:
 - Prepare a solution of the host material and the fluorinated TADF emitter (e.g., 10 wt% doping) in chlorobenzene.
 - Spin-coat the EML solution onto the PEDOT:PSS layer in a nitrogen-filled glovebox.
 - Anneal the substrate at 70 °C for 30 minutes.

- HBL/EBL, ETL, and Cathode Deposition:
 - Transfer the substrates to a thermal evaporator.
 - Sequentially deposit a 10 nm layer of DPEPO, a 40 nm layer of TPBi, a 1.2 nm layer of LiF, and a 100 nm layer of Al.
- Device Characterization:
 - Measure the current density-voltage-luminance (J-V-L) characteristics of the OLED.
 - Determine the external quantum efficiency (EQE), power efficiency, and Commission Internationale de l'Éclairage (CIE) color coordinates.

Part 3: Advanced Characterization Techniques

A thorough understanding of the properties of fluorinated building blocks and their corresponding thin films is essential for optimizing device performance. This section details key characterization techniques.

Cyclic Voltammetry (CV)

CV is an electrochemical technique used to determine the HOMO and LUMO energy levels of a material.^[17]

Protocol: CV of a Fluorinated Polymer Thin Film

Materials:

- Three-electrode electrochemical cell (working, counter, and reference electrodes)
- Potentiostat
- Electrolyte solution (e.g., 0.1 M tetrabutylammonium hexafluorophosphate in acetonitrile)
- Fluorinated polymer film deposited on a conductive substrate (e.g., ITO or platinum)
- Ferrocene (for calibration)

Procedure:

- **Cell Assembly:** Assemble the three-electrode cell with the polymer film as the working electrode, a platinum wire as the counter electrode, and an Ag/AgCl electrode as the reference electrode.
- **Degassing:** Purge the electrolyte solution with an inert gas (argon or nitrogen) for at least 15 minutes to remove dissolved oxygen.
- **Measurement:**
 - Scan the potential of the working electrode towards positive potentials to measure the oxidation onset (for HOMO level determination).
 - Scan the potential towards negative potentials to measure the reduction onset (for LUMO level determination).
- **Calibration:** After the measurement, add a small amount of ferrocene to the solution and record its cyclic voltammogram. The ferrocene/ferrocenium (Fc/Fc⁺) redox couple is used as an internal standard.
- **Data Analysis:** Determine the onset oxidation and reduction potentials from the voltammograms. Calculate the HOMO and LUMO energy levels using the following equations:
 - $E_{\text{HOMO}} = -[E_{\text{ox}}(\text{onset}) - E_{\text{Fc/Fc}^+}(1/2) + 4.8] \text{ eV}$
 - $E_{\text{LUMO}} = -[E_{\text{red}}(\text{onset}) - E_{\text{Fc/Fc}^+}(1/2) + 4.8] \text{ eV}$

UV-Visible (UV-Vis) Spectroscopy

UV-Vis spectroscopy is used to investigate the optical properties of materials, including their absorption and the optical bandgap.^{[18][19]}

Protocol: UV-Vis Spectroscopy of a Fluorinated Polymer Thin Film

Materials:

- UV-Vis spectrophotometer
- Quartz substrate
- Fluorinated polymer solution

Procedure:

- Thin Film Preparation: Prepare a thin film of the fluorinated polymer on a quartz substrate by spin-coating or drop-casting.
- Measurement:
 - Place the quartz substrate with the polymer film in the sample holder of the spectrophotometer.
 - Use a bare quartz substrate as a reference.
 - Record the absorption spectrum over the desired wavelength range (typically 200-1100 nm).
- Data Analysis:
 - Identify the absorption maxima (λ_{max}).
 - Determine the optical bandgap ($E_{\text{g}}^{\text{opt}}$) from the onset of the absorption edge using the Tauc plot method.

Atomic Force Microscopy (AFM)

AFM is a high-resolution imaging technique used to characterize the surface morphology and topography of thin films.[\[20\]](#)[\[21\]](#)[\[22\]](#)

Protocol: AFM Imaging of a Fluorinated Semiconductor Thin Film

Materials:

- Atomic Force Microscope

- Sample with the fluorinated semiconductor thin film
- AFM cantilevers (tapping mode cantilevers are commonly used for soft organic films)

Procedure:

- Sample Mounting: Mount the sample on the AFM stage.
- Cantilever Installation and Laser Alignment: Install the cantilever and align the laser onto the cantilever.
- Tuning: Tune the cantilever to its resonant frequency for tapping mode operation.
- Imaging:
 - Approach the tip to the sample surface.
 - Optimize the imaging parameters (scan size, scan rate, setpoint, and gains) to obtain a high-quality image.
 - Acquire both height and phase images. The height image provides topographical information, while the phase image can reveal variations in material properties.
- Data Analysis:
 - Analyze the images to determine the root-mean-square (RMS) roughness of the film.
 - Characterize the morphology, such as the presence of crystalline domains or phase separation.

Grazing-Incidence Wide-Angle X-ray Scattering (GIWAXS)

GIWAXS is a powerful technique for probing the molecular packing and orientation of crystalline domains in thin films.[\[4\]](#)[\[9\]](#)[\[23\]](#)[\[24\]](#)

Protocol: GIWAXS Analysis of a Fluorinated Polymer Thin Film

Materials:

- Synchrotron or laboratory-based GIWAXS instrument
- Sample with the fluorinated polymer thin film on a suitable substrate (e.g., silicon)

Procedure:

- **Sample Alignment:** Mount the sample on the goniometer and align it with respect to the incident X-ray beam at a shallow angle (typically 0.1-0.2 degrees).
- **Data Acquisition:** Acquire the 2D scattering pattern using an area detector.
- **Data Analysis:**
 - Analyze the positions and intensities of the diffraction peaks in both the in-plane and out-of-plane directions.
 - Determine the crystal structure, lattice parameters, and the orientation of the polymer chains with respect to the substrate (e.g., "edge-on" or "face-on").
 - Calculate the π - π stacking distance and lamellar spacing.

Diagram: Molecular Orientation in Thin Films

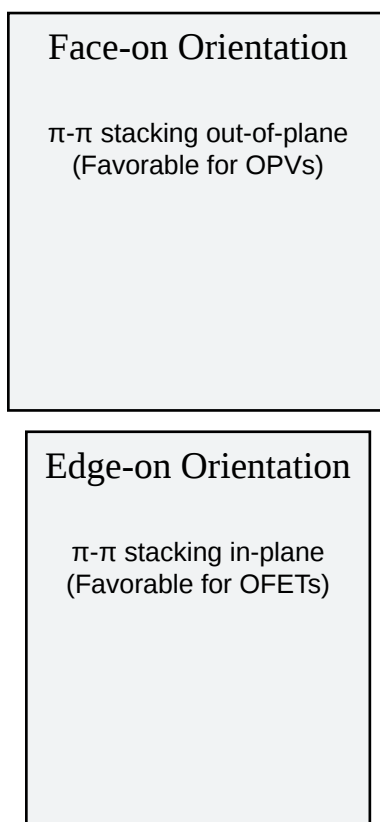

[Click to download full resolution via product page](#)

Caption: "Edge-on" vs. "Face-on" molecular orientation in thin films.

Conclusion

Fluorinated building blocks are undeniably a cornerstone of modern organic electronics. Their unique ability to fine-tune the electronic and morphological properties of organic semiconductors has led to significant breakthroughs in device performance and stability. The protocols and application notes provided in this guide offer a comprehensive framework for researchers and professionals to harness the full potential of these remarkable materials. By understanding the causality behind experimental choices and adhering to rigorous, self-validating protocols, the field of organic electronics will continue to advance, paving the way for next-generation flexible, transparent, and low-cost electronic devices.

References

- Facile Synthesis of Fluorine-Substituted Benzothiadiazole-Based Organic Semiconductors and Their Use in Solution-Processed Small-Molecule Organic Solar Cells. (2025-08-06). ResearchGate. [\[Link\]](#)
- Fluorinated Benzothiadiazole-Based Polymers for Organic Solar Cells: Progress and Prospects. (n.d.). ACS Publications. [\[Link\]](#)
- Synthesis of fluorinated monomer and formation of hydrophobic surface therefrom. (n.d.). ResearchGate. [\[Link\]](#)
- Synthesis of New Fluoroboronated Materials by Chemical Modification of Fluorinated Functional Polymers. (2025-05-19). National Center for Biotechnology Information. [\[Link\]](#)
- Synthesis and self-assembly of fluorinated block copolymers. (2025-08-06). ResearchGate. [\[Link\]](#)
- Fluorinated Benzothiadiazole-Based Polymers for Organic Solar Cells: Progress and Prospects. (n.d.). National Center for Biotechnology Information. [\[Link\]](#)
- Synthesis and Characterization of Benzothiadiazole Derivatives as Organic Semiconductors for Organic Thin-Film Transistors. (2016). PubMed. [\[Link\]](#)
- Fabrication of organic field effect transistor using low temperature annealed fluorinated block copolymer. (n.d.). SPIE Digital Library. [\[Link\]](#)
- TADF based OLED Devices. (2019). ResearchGate. [\[Link\]](#)
- Step-by-Step Guide for Harnessing Organic Light Emitting Diodes by Solution Processed Device Fabrication of a TADF Emitter. (2025-11-14). ResearchGate. [\[Link\]](#)
- 10.8% Efficiency Polymer Solar Cells Based on PTB7-Th and PC 71 BM via Binary Solvent Additives Treatment. (2016). ResearchGate. [\[Link\]](#)
- TADF OLED emitters, introduction and market status. (2025-11-30). OLED-Info. [\[Link\]](#)
- Method of Organic Semiconductor Thin Film. (n.d.). Stanford University. [\[Link\]](#)

- Comparative study of PTB7:PC71BM based polymer solar cells fabricated under different working environments. (n.d.). ResearchGate. [\[Link\]](#)
- Fabrication of a Solution-Processed White Light Emitting Diode Containing a Single Dimeric Copper(I) Emitter Featuring Combined TADF and Phosphorescence. (n.d.). MDPI. [\[Link\]](#)
- Efficient N-Type Organic Electrochemical Transistors and Field-Effect Transistors Based on PNDI-Copolymers Bearing. (2024). UDSMM. [\[Link\]](#)
- UV-Vis absorption spectra of polymers in chloroform solution (a) and in thin films (b). (n.d.). ResearchGate. [\[Link\]](#)
- Morphological Transitions in Organic Ultrathin Film Growth Imaged by In Situ Step-by-Step Atomic Force Microscopy. (2020). ACS Publications. [\[Link\]](#)
- Flexible organic field-effect transistors-based biosensors: progress and perspectives. (2023). National Center for Biotechnology Information. [\[Link\]](#)
- Solution self-assembly of fluorinated polymers, an overview. (n.d.). Royal Society of Chemistry. [\[Link\]](#)
- Chain-Growth Suzuki Polymerization of n-Type Fluorene Copolymers. (n.d.). ACS Publications. [\[Link\]](#)
- Control of Fluoropolymer Crystallinity for Flexible, Transparent Optical Thin Films with Low Refractive Indexes. (n.d.). National Center for Biotechnology Information. [\[Link\]](#)
- Interpretation of Cyclic Voltammetry Measurements of Thin Semiconductor Films for Solar Fuel Applications. (n.d.). Semantic Scholar. [\[Link\]](#)
- Scaling of inverted PTB7-Th: PC71BM organic solar cell for large area organic photovoltaic modules. (2024). Oxford Academic. [\[Link\]](#)
- Self-assembly of poly (ionic liquid) block copolymer based dielectrics on semiconductor formation and performance. (n.d.). The Lessard Research Group. [\[Link\]](#)

- Atomic force microscopy (AFM) of freely suspended organic thin films... (n.d.). ResearchGate. [\[Link\]](#)
- AFM Characterization of Thin Films: High-Resolution Topography and Functional Properties. (n.d.). Spectra Research Corporation. [\[Link\]](#)
- Control of Fluoropolymer Crystallinity for Flexible, Transparent Optical Thin Films with Low Refractive Indexes. (n.d.). ACS Publications. [\[Link\]](#)
- Probing Functional Thin Films with Grazing Incidence X-Ray Scattering: The Power of Indexing. (n.d.). MDPI. [\[Link\]](#)
- Effect of Fluorination of 2,1,3-Benzothiadiazole. (2015). The Journal of Organic Chemistry. [\[Link\]](#)
- Suzuki–Miyaura Catalyst-Transfer Polycondensation of Triolborate-Type Fluorene Monomer: Toward Rapid Access to Polyfluorene-Containing Block and Graft Copolymers from Various Macroinitiators. (2020). The Royal Society of Chemistry. [\[Link\]](#)
- Boosting the efficiency of PTB7-Th:PC71BM polymer solar cells via a low-cost halogen-free supramolecular solid additive. (n.d.). Royal Society of Chemistry. [\[Link\]](#)
- Polymer Thin Films as Universal Substrates for Extreme Ultraviolet Absorption Spectroscopy of Molecular Transition Metal Complex. (n.d.). arXiv.org. [\[Link\]](#)
- Organic Semiconductor Field-Effect Transistors Based on Organic-2D Heterostructures. (n.d.). Frontiers. [\[Link\]](#)
- Time-Resolved In Situ Liquid-Phase Atomic Force Microscopy and Infrared Nanospectroscopy during the Formation of Metal–Organic Framework Thin Films. (2018). ACS Publications. [\[Link\]](#)
- Synthesis of Conjugated Polymers by Sustainable Suzuki Polycondensation in Water and under Aerobic Conditions. (2020). ACS Publications. [\[Link\]](#)
- Grazing-incidence X-ray diffraction tomography for characterizing organic thin films. (2021). National Center for Biotechnology Information. [\[Link\]](#)

- Enhanced performance of polymer solar cells based on PTB7-Th:PC71BM by doping with 1-bromo-4-nitrobenzene. (n.d.). Journal of Materials Chemistry C. [\[Link\]](#)
- Thin-Film Analysis Using UV-Vis Spectrophotometry. (2014). PCI Magazine. [\[Link\]](#)
- GISAXS for thin film polymer characterization. (n.d.). University of Washington. [\[Link\]](#)
- Synthesis of partially fluorinated polyolefins via copolymerization of ethylene with fluorinated norbornene-based comonomers. (n.d.). Polymer Chemistry. [\[Link\]](#)
- Bidirectional Suzuki Catalyst Transfer Polymerization of Poly(p-phenylene). (2025-08-15). eScholarship.org. [\[Link\]](#)
- Electrochemically Controlled Deposition of Oriented Fluorinated Covalent Organic Framework Films for Selective Electrochemical Sensing. (2026-01-18). ResearchGate. [\[Link\]](#)
- Highly Selective Electrochemical Fluorination of Organic Compounds in Ionic Liquids. (2025-08-05). ResearchGate. [\[Link\]](#)
- Impact of Coating Speed and Temperature on Organic Field-Effect Transistor (OFET) Performance. (n.d.). Lehigh University. [\[Link\]](#)

Need Custom Synthesis?

BenchChem offers custom synthesis for rare earth carbides and specific isotopic labeling.

Email: info@benchchem.com or [Request Quote Online](#).

Sources

- 1. pubs.acs.org [pubs.acs.org]
- 2. Solution self-assembly of fluorinated polymers, an overview - Polymer Chemistry (RSC Publishing) [pubs.rsc.org]
- 3. Fluorinated Benzothiadiazole-Based Polymers for Organic Solar Cells: Progress and Prospects - PMC [[pmc.ncbi.nlm.nih.gov](https://pubmed.ncbi.nlm.nih.gov)]
- 4. mdpi.com [mdpi.com]

- [5. pubs.rsc.org \[pubs.rsc.org\]](https://pubs.rsc.org)
- [6. pubs.acs.org \[pubs.acs.org\]](https://pubs.acs.org)
- [7. escholarship.org \[escholarship.org\]](https://escholarship.org)
- [8. Flexible organic field-effect transistors-based biosensors: progress and perspectives - PMC \[pmc.ncbi.nlm.nih.gov\]](#)
- [9. researchgate.net \[researchgate.net\]](https://researchgate.net)
- [10. researchgate.net \[researchgate.net\]](https://researchgate.net)
- [11. academic.oup.com \[academic.oup.com\]](https://academic.oup.com)
- [12. Enhanced performance of polymer solar cells based on PTB7-Th:PC71BM by doping with 1-bromo-4-nitrobenzene - Journal of Materials Chemistry C \(RSC Publishing\) \[pubs.rsc.org\]](#)
- [13. researchgate.net \[researchgate.net\]](https://researchgate.net)
- [14. oled-info.com \[oled-info.com\]](https://oled-info.com)
- [15. mdpi.com \[mdpi.com\]](https://mdpi.com)
- [16. ossila.com \[ossila.com\]](https://ossila.com)
- [17. Synthesis and Characterization of Benzothiadiazole Derivatives as Organic Semiconductors for Organic Thin-Film Transistors - PubMed \[pubmed.ncbi.nlm.nih.gov\]](#)
- [18. researchgate.net \[researchgate.net\]](https://researchgate.net)
- [19. pcimag.com \[pcimag.com\]](https://pcimag.com)
- [20. pubs.acs.org \[pubs.acs.org\]](https://pubs.acs.org)
- [21. researchgate.net \[researchgate.net\]](https://researchgate.net)
- [22. spectraresearch.com \[spectraresearch.com\]](https://spectraresearch.com)
- [23. Grazing-incidence X-ray diffraction tomography for characterizing organic thin films - PMC \[pmc.ncbi.nlm.nih.gov\]](#)
- [24. GISAXS for thin film polymer characterization - Clean Energy Institute \[cei.washington.edu\]](#)
- To cite this document: BenchChem. [Application Notes and Protocols for Fluorinated Building Blocks in Organic Electronics]. BenchChem, [2026]. [Online PDF]. Available at: [<https://www.benchchem.com/product/b1405346/docs#application-notes-and-protocols-for-fluorinated-building-blocks-in-organic-electronics>]

Disclaimer & Data Validity:

The information provided in this document is for Research Use Only (RUO) and is strictly not intended for diagnostic or therapeutic procedures. While BenchChem strives to provide accurate protocols, we make no warranties, express or implied, regarding the fitness of this product for every specific experimental setup.

Technical Support: The protocols provided are for reference purposes. Unsure if this reagent suits your experiment?

Need Industrial/Bulk Grade? [Request Custom Synthesis Quote](#)

BenchChem

Our mission is to be the trusted global source of essential and advanced chemicals, empowering scientists and researchers to drive progress in science and industry.

Contact

Address: 3281 E Guasti Rd
Ontario, CA 91761, United States
Phone: (601) 213-4426
Email: info@benchchem.com

[Contact our Ph.D. Support Team for a compatibility check](#)