

A Comparative Guide to Surface Density Analysis of 9-Azido-1-nonanol Monolayers

Author: BenchChem Technical Support Team. **Date:** May 2026

Compound of Interest

Compound Name: 9-Azido-1-nonanol

CAS No.: 57395-47-8

Cat. No.: B1405113

[Get Quote](#)

For researchers, scientists, and drug development professionals, the precise characterization of self-assembled monolayers (SAMs) is paramount for the development of robust and reliable surface chemistries. **9-Azido-1-nonanol** has emerged as a critical component in the fabrication of biocompatible and functionalized surfaces, primarily due to its terminal azide group, which provides a versatile handle for "click" chemistry, and the hydroxyl group for surface attachment. The surface density of these monolayers is a critical parameter that dictates the efficiency of subsequent molecular immobilization and, ultimately, the performance of the device or assay.

This guide provides an in-depth comparison of various analytical techniques to determine the surface density of **9-Azido-1-nonanol** monolayers. We will delve into the causality behind experimental choices, present self-validating protocols, and compare the performance of **9-Azido-1-nonanol** with alternative monolayer systems.

The Significance of Surface Density in Monolayer Performance

Self-assembled monolayers are highly ordered molecular assemblies formed spontaneously on a substrate.^[1] The packing density of a **9-Azido-1-nonanol** monolayer directly influences

several key surface properties:

- **Reaction Kinetics:** A higher density of azide groups can lead to faster reaction rates in subsequent "click" chemistry modifications.
- **Blocking Efficiency:** Densely packed monolayers are more effective at preventing non-specific binding of biomolecules, a crucial aspect in biosensor and drug delivery applications.
- **Stability:** A well-ordered, dense monolayer exhibits greater stability against environmental factors and degradation over time.[2]

Therefore, accurate determination of surface density is not merely a characterization step but a critical quality control measure in the development of SAM-based technologies.

Comparative Analysis of Surface Density Characterization Techniques

Several techniques can be employed to analyze the surface density of self-assembled monolayers.[1] Each method offers distinct advantages and is based on different physical principles. Here, we compare four prominent techniques: X-ray Photoelectron Spectroscopy (XPS), Contact Angle Goniometry, Electrochemical Impedance Spectroscopy (EIS), and Quartz Crystal Microbalance with Dissipation Monitoring (QCM-D).

X-ray Photoelectron Spectroscopy (XPS)

Principle: XPS, also known as Electron Spectroscopy for Chemical Analysis (ESCA), is a surface-sensitive quantitative spectroscopic technique that measures the elemental composition, empirical formula, chemical state, and electronic state of the elements within the top 1-10 nm of a material.[3][4] By irradiating the surface with X-rays, photoelectrons are emitted, and their kinetic energy is measured.[5][6] The intensity of the photoelectron signal is proportional to the number of atoms of that element on the surface, allowing for the calculation of surface coverage.

Experimental Protocol: XPS Analysis of **9-Azido-1-nonanol** SAMs

- **Substrate Preparation:** Begin with a clean, smooth substrate (e.g., gold or silicon). A common cleaning procedure involves sonication in a series of solvents (e.g., acetone,

ethanol, and deionized water) followed by plasma or piranha cleaning to create a hydrophilic surface.

- **SAM Formation:** Immerse the cleaned substrate in a dilute solution (e.g., 1-5 mM) of **9-Azido-1-nonanol** in a suitable solvent like ethanol or toluene for a specified time (typically 12-24 hours) to allow for the formation of a well-ordered monolayer.
- **Rinsing and Drying:** After incubation, thoroughly rinse the substrate with the same solvent to remove any physisorbed molecules and then dry under a stream of inert gas (e.g., nitrogen or argon).
- **XPS Measurement:** Introduce the sample into the ultra-high vacuum chamber of the XPS instrument. Acquire a survey spectrum to identify the elements present on the surface. Then, perform high-resolution scans of the relevant elemental regions (C 1s, N 1s, O 1s, and the substrate signal, e.g., Au 4f or Si 2p).
- **Data Analysis:** Integrate the peak areas of the elemental signals. The surface coverage (Γ) can be calculated using the following equation, which relates the intensity of the adsorbate signal (e.g., N 1s for the azide group) to the substrate signal:

$$\Gamma = (IA / SA) / (IS / SS) * \lambda S * \rho S * \cos(\theta)$$

where I is the peak intensity, S is the relative sensitivity factor for the element, λ is the inelastic mean free path of the photoelectrons, ρ is the atomic density of the substrate, and θ is the take-off angle of the photoelectrons.

Causality and Trustworthiness: The strength of XPS lies in its ability to provide direct elemental quantification. The presence and stoichiometry of nitrogen from the azide group serve as a direct measure of the **9-Azido-1-nonanol** molecules on the surface.^[6] This method is self-validating as the elemental ratios (e.g., C:N:O) should correspond to the molecular formula of **9-Azido-1-nonanol**.

Diagram: XPS Experimental Workflow

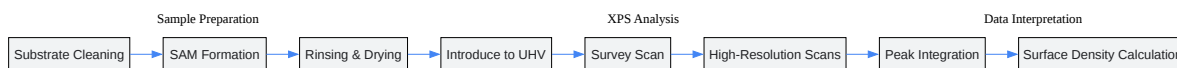

[Click to download full resolution via product page](#)

Caption: Workflow for XPS surface density analysis.

Contact Angle Goniometry

Principle: Contact angle goniometry is a surface characterization technique that measures the angle at which a liquid droplet interfaces with a solid surface.[7] This angle is a measure of the surface's wettability, which is directly influenced by the chemical composition and packing of the monolayer.[8] A well-formed, dense hydrophobic monolayer will exhibit a high contact angle with water.

Experimental Protocol: Contact Angle Measurement

- **Sample Preparation:** Prepare the **9-Azido-1-nonanol** SAM on a substrate as described in the XPS protocol.
- **Measurement Setup:** Place the sample on the stage of the contact angle goniometer.
- **Droplet Deposition:** Dispense a small droplet (typically 2-5 μL) of a probe liquid (e.g., deionized water) onto the surface.
- **Image Acquisition and Analysis:** A camera captures the profile of the droplet. Software then analyzes the image to determine the contact angle at the three-phase (solid-liquid-vapor) contact line.
- **Interpretation:** The measured contact angle is compared to literature values for well-packed monolayers. For a **9-Azido-1-nonanol** monolayer, the presence of the hydrophilic alcohol group and the relatively short alkyl chain will result in a moderate contact angle. Changes in contact angle can indicate variations in monolayer density and order.

Causality and Trustworthiness: This technique provides an indirect but highly sensitive measure of surface modification. The causality lies in the relationship between surface energy and molecular packing. A more densely packed monolayer will present a more uniform and chemically distinct surface, leading to a consistent and reproducible contact angle. While not providing a direct quantitative value of molecules per unit area, it is an excellent tool for assessing the quality and consistency of the monolayer formation.

Electrochemical Impedance Spectroscopy (EIS)

Principle: EIS is a powerful technique for probing the properties of surface-modified electrodes. [9] It involves applying a small amplitude AC voltage over a range of frequencies and measuring the resulting current. [10] A well-packed, defect-free monolayer acts as a dielectric layer, impeding the flow of charge between the electrode and a redox probe in the electrolyte. The degree of this impedance can be related to the surface coverage.

Experimental Protocol: EIS Analysis

- **Electrode Preparation:** Form the **9-Azido-1-nonanol** SAM on a conductive substrate, such as a gold electrode.
- **Electrochemical Cell Setup:** Place the modified electrode in an electrochemical cell containing an electrolyte and a redox probe (e.g., a solution of $[\text{Fe}(\text{CN})_6]^{3-/4-}$). A three-electrode setup with a reference and counter electrode is used.
- **EIS Measurement:** Apply a DC potential to the working electrode and superimpose a small AC voltage (e.g., 5-10 mV) over a wide frequency range (e.g., 100 kHz to 0.1 Hz).
- **Data Analysis:** The impedance data is typically plotted in a Nyquist plot (imaginary vs. real impedance). The data can be fitted to an equivalent circuit model. The charge transfer resistance (R_{ct}) is a key parameter that increases with increasing surface coverage, as the monolayer blocks the access of the redox probe to the electrode surface. The surface coverage (θ) can be estimated using the equation:

$$\theta = 1 - (R_{ct,bare} / R_{ct,SAM})$$

where $R_{ct,bare}$ and $R_{ct,SAM}$ are the charge transfer resistances of the bare and SAM-modified electrodes, respectively.

Causality and Trustworthiness: The causality is based on the insulating properties of the alkyl chains in the monolayer. A higher surface density results in a more effective barrier to electron transfer, leading to a larger charge transfer resistance.[11] This method is self-validating by comparing the impedance of the modified electrode to that of a bare electrode.

Diagram: EIS Measurement Principle

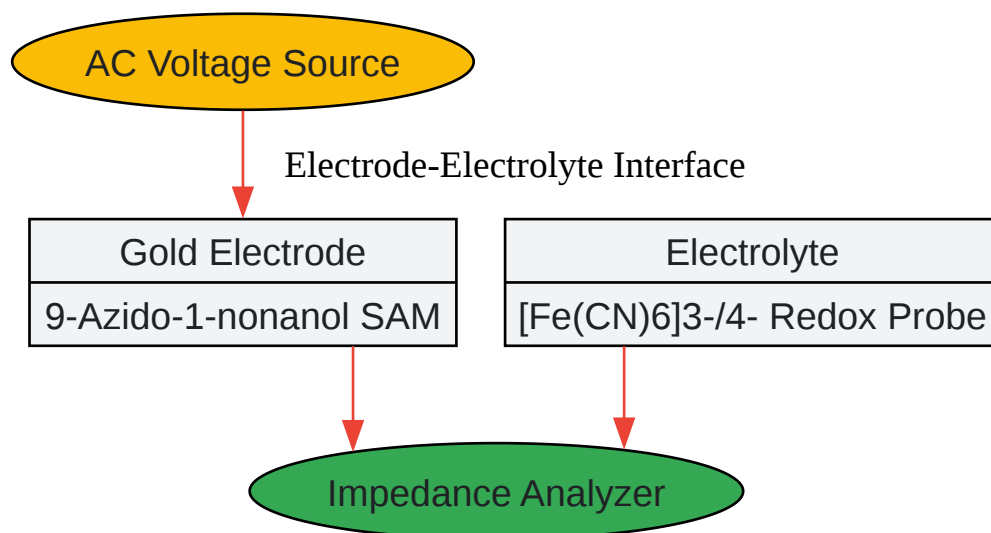

[Click to download full resolution via product page](#)

Caption: Principle of EIS for SAM characterization.

Quartz Crystal Microbalance with Dissipation Monitoring (QCM-D)

Principle: QCM-D is a highly sensitive mass-sensing technique that measures changes in the resonance frequency and energy dissipation of a quartz crystal sensor.[12][13] When molecules adsorb onto the sensor surface, the resonance frequency decreases in proportion to the added mass.[14] The dissipation provides information about the viscoelastic properties of the adsorbed layer.

Experimental Protocol: QCM-D Analysis

- **Sensor Preparation:** Use a quartz crystal sensor coated with a suitable substrate material (e.g., gold). Clean the sensor thoroughly.

- **Baseline Measurement:** Establish a stable baseline by flowing a buffer solution over the sensor surface.
- **SAM Formation:** Introduce a solution of **9-Azido-1-nonanol** into the QCM-D chamber. The formation of the monolayer is monitored in real-time by observing the decrease in frequency and change in dissipation.
- **Rinsing:** After the SAM formation has reached a plateau, rinse with a clean buffer to remove any non-adsorbed molecules.
- **Data Analysis:** The change in frequency (Δf) is related to the adsorbed mass (Δm) by the Sauerbrey equation (for rigid films):

$$\Delta m = -C * \Delta f / n$$

where C is the mass sensitivity constant of the crystal and n is the overtone number. From the adsorbed mass and the sensor area, the surface density can be calculated.

Causality and Trustworthiness: The direct proportionality between the change in frequency and the adsorbed mass provides a quantitative measure of surface coverage.^[12] The simultaneous measurement of dissipation helps to ensure that the monolayer is rigid, a condition for the accurate application of the Sauerbrey equation.

Comparison of 9-Azido-1-nonanol with Alternative Monolayer Systems

While **9-Azido-1-nonanol** is a versatile molecule for surface functionalization, other molecules can be used to form SAMs, each with its own advantages and disadvantages.^[15]

Molecule	Head Group	Terminal Group	Key Advantages	Typical Substrate
9-Azido-1-nonanol	Hydroxyl (-OH)	Azide (-N ₃)	Versatile for "click" chemistry, biocompatible.	Silicon dioxide, glass, metal oxides.
11-Mercaptoundecanoic Acid (MUA)	Thiol (-SH)	Carboxylic Acid (-COOH)	Strong gold-sulfur bond, provides carboxyl groups for amine coupling.	Gold, silver, copper.[2]
(3-Aminopropyl)triethoxysilane (APTES)	Silane (-Si(OEt) ₃)	Amine (-NH ₂)	Forms robust siloxane bonds, provides primary amines for conjugation.	Silicon dioxide, glass, metal oxides.
Octadecanethiol (ODT)	Thiol (-SH)	Methyl (-CH ₃)	Forms highly ordered, hydrophobic monolayers, excellent for passivation.	Gold, silver, copper.[2]

Table 1: Comparison of Common Self-Assembled Monolayer Molecules.

The choice of monolayer system depends on the specific application, the substrate material, and the desired surface functionality. For applications requiring bio-orthogonal ligation, **9-Azido-1-nonanol** is an excellent choice. For creating negatively charged surfaces or for EDC/NHS chemistry, MUA is often preferred. APTES is ideal for creating positively charged surfaces and for applications requiring robust covalent attachment to silica-based substrates. ODT is a standard for creating well-defined, inert hydrophobic surfaces.

Quantitative Data Summary

The following table summarizes typical surface density values obtained for different monolayers using various techniques. These values can vary depending on the specific experimental conditions.

Monolayer	Technique	Typical Surface Density (molecules/cm ²)
9-Azido-1-nonanol on SiO ₂	XPS	2 - 4 x 10 ¹⁴
11-Mercaptoundecanoic Acid on Au	EIS	4 - 5 x 10 ¹⁴
(3-Aminopropyl)triethoxysilane on SiO ₂	QCM-D	3 - 5 x 10 ¹⁴
Octadecanethiol on Au	XPS	4.6 x 10 ¹⁴

Table 2: Typical Surface Densities of Common SAMs.

Conclusion

The accurate determination of the surface density of **9-Azido-1-nonanol** monolayers is crucial for the successful development of a wide range of applications in research, diagnostics, and drug development. This guide has provided a comparative overview of four key analytical techniques: XPS, contact angle goniometry, EIS, and QCM-D. Each technique offers a unique perspective on the monolayer's properties, and a multi-technique approach is often the most effective strategy for comprehensive characterization. The choice of the optimal technique will depend on the available instrumentation, the nature of the substrate, and the specific information required. By understanding the principles and protocols outlined in this guide, researchers can make informed decisions to ensure the quality and performance of their **9-Azido-1-nonanol**-based surface modifications.

References

- SELF ASSEMBLED MONOLAYERS-A REVIEW. (n.d.).
- Self-assembled monolayer - Wikipedia. (n.d.).
- Characterization techniques for SAMs | Molecular Electronics Class Notes - Fiveable. (n.d.).
- Electrochemical and X-ray Photoelectron Spectroscopy Surface Characterization of Interchain-Driven Self-Assembled Monolayer (SAM) Reorganization - MDPI. (n.d.).

- Self-assembled monolayers (SAMs) - Darren Lipomi - UC San Diego - YouTube. (2019, November 26).
- Electrochemical Impedance Spectroscopy A Tutorial | ACS Measurement Science Au. (n.d.).
- Determining Surface Coverage of Self-Assembled Monolayers on Gold Electrodes. (2025, August 7).
- 1-Nonanol | C₉H₂₀O | CID 8914 - PubChem. (n.d.).
- What is Quartz Crystal Microbalance with Dissipation (QCM-D) Monitoring? (n.d.).
- Contact Angle Measurements and Wettability - Nanoscience Instruments. (n.d.).
- Molecular Self-Assembly - Sigma-Aldrich. (n.d.).
- Mass Spectrometry of Self-Assembled Monolayers: A New Tool for Molecular Surface Science - PMC - NIH. (n.d.).
- Quartz Crystal Microbalance with Dissipation Monitoring: Enabling Real-Time Characterization of Biological Materials and Their Interactions - NIH. (n.d.).
- Employing X-ray Photoelectron Spectroscopy for Determining Layer Homogeneity in Mixed Polar Self-Assembled Monolayers | The Journal of Physical Chemistry Letters - ACS Publications. (2016, July 18).
- 1-Nonanol - the NIST WebBook. (n.d.).
- Electrochemical impedance spectroscopy study of carbohydrate-terminated alkanethiol monolayers on nanoporous gold: Implications for pore wetting - NIH. (n.d.).
- Contact Angle Goniometry, Ellipsometry, XPS, and TOF-SIMS Analysis of Gold-Supported, Mixed Self-Assembled Monolayers Formed from Mixed Dialkyl Disulfides | Langmuir - ACS Publications. (n.d.).
- Contact Angle Goniometer Applications - Ossila. (n.d.).
- Electrochemical impedance spectroscopy data for mixed SAMs of... - ResearchGate. (n.d.).
- Quartz Crystal Microbalance with Dissipation Monitoring - Science topic - ResearchGate. (n.d.).
- New self-assembled monolayer is resistant to air | News articles | University of Groningen. (2020, January 20).
- Contact Angle Goniometer 101: Guide to Measuring Contact Angle - Brighton Science. (n.d.).
- SAM (self-assembled monolayer)-based Photocatalytic Chip from Immobilized Polytriazoles - ChemRxiv. (n.d.).
- Electrochemical impedance spectroscopy (EIS) studies of self-assemble monolayers (SAM) on aluminum substrates | Request PDF - ResearchGate. (n.d.).
- Three-Dimensional Behaviors of Protein Molecules and Bacteria near Model Organic Surfaces in Real Crowding Conditions - MDPI. (n.d.).
- Self-Assembled Monolayers (SAMs), PEDOT:PSS Alternative | Ossila. (n.d.).
- Quartz Crystal Microbalance with Dissipation (QCM-D) - Biolin Scientific. (n.d.).

- Introduction to electrochemical impedance spectroscopy (EIS) for battery research. (2021, September 8). Retrieved from [\[Link\]](#)

Need Custom Synthesis?

BenchChem offers custom synthesis for rare earth carbides and specific isotopic labeling.

Email: info@benchchem.com or [Request Quote Online](#).

Sources

- [1. sphinxsai.com \[sphinxsai.com\]](#)
- [2. Self-assembled monolayer - Wikipedia \[en.wikipedia.org\]](#)
- [3. images.philips.com \[images.philips.com\]](#)
- [4. covalent.com \[covalent.com\]](#)
- [5. fiveable.me \[fiveable.me\]](#)
- [6. mdpi.com \[mdpi.com\]](#)
- [7. brighton-science.com \[brighton-science.com\]](#)
- [8. ossila.com \[ossila.com\]](#)
- [9. pubs.acs.org \[pubs.acs.org\]](#)
- [10. m.youtube.com \[m.youtube.com\]](#)
- [11. Electrochemical impedance spectroscopy study of carbohydrate-terminated alkanethiol monolayers on nanoporous gold: Implications for pore wetting - PMC \[pmc.ncbi.nlm.nih.gov\]](#)
- [12. nanoscience.com \[nanoscience.com\]](#)
- [13. Quartz Crystal Microbalance with Dissipation Monitoring: Enabling Real-Time Characterization of Biological Materials and Their Interactions - PMC \[pmc.ncbi.nlm.nih.gov\]](#)
- [14. biolinscientific.com \[biolinscientific.com\]](#)
- [15. ossila.com \[ossila.com\]](#)
- To cite this document: BenchChem. [A Comparative Guide to Surface Density Analysis of 9-Azido-1-nonanol Monolayers]. BenchChem, [2026]. [Online PDF]. Available at: [\[https://www.benchchem.com/product/b1405113/docs#a-comparative-guide-to-surface-density-analysis-of-9-azido-1-nonanol-monolayers\]](https://www.benchchem.com/product/b1405113/docs#a-comparative-guide-to-surface-density-analysis-of-9-azido-1-nonanol-monolayers)

Disclaimer & Data Validity:

The information provided in this document is for Research Use Only (RUO) and is strictly not intended for diagnostic or therapeutic procedures. While BenchChem strives to provide accurate protocols, we make no warranties, express or implied, regarding the fitness of this product for every specific experimental setup.

Technical Support: The protocols provided are for reference purposes. Unsure if this reagent suits your experiment?

Need Industrial/Bulk Grade? [Request Custom Synthesis Quote](#)

BenchChem

Our mission is to be the trusted global source of essential and advanced chemicals, empowering scientists and researchers to drive progress in science and industry.

Contact

Address: 3281 E Guasti Rd
Ontario, CA 91761, United States
Phone: (601) 213-4426
Email: info@benchchem.com

[Contact our Ph.D. Support Team for a compatibility check](#)