

Application Note: One-Pot Synthesis of Isochromans from α -Chloro Ketones

Author: BenchChem Technical Support Team. **Date:** April 2026

Compound of Interest

Compound Name: 1-Chloro-1-(2-(hydroxymethyl)phenyl)propan-2-one

Cat. No.: B14049894

[Get Quote](#)

Executive Summary

The isochroman (3,4-dihydro-1H-2-benzopyran) scaffold is a privileged structure in medicinal chemistry, found in various bioactive natural products and pharmaceuticals.[1] Traditional synthesis often relies on the reaction of 2-phenylethanols with aldehydes.[1] However, the use of

α -chloro ketones as electrophiles offers a distinct advantage: it introduces a 1-chloromethyl handle directly into the isochroman core.[1] This moiety is highly versatile for late-stage diversification (e.g., via nucleophilic substitution with amines or azides).

This guide outlines a robust, one-pot protocol for coupling

α -chloro ketones with 2-phenylethanols using Lewis acid catalysis.[1] The method circumvents the lower reactivity of ketones compared to aldehydes by leveraging the inductive activation of the

α -chloro group and high-efficiency catalysts.[1]

Scientific Foundation & Mechanism[1]

The Challenge of Ketone Electrophiles

In the Oxa-Pictet-Spengler reaction, ketones are generally less reactive than aldehydes due to steric hindrance and the greater stability of the ketone carbonyl.[1] However,

-chloro ketones possess unique electronic properties:

- Inductive Activation: The electron-withdrawing chlorine atom increases the electrophilicity of the carbonyl carbon (), facilitating the initial nucleophilic attack by the alcohol.[1]
- Oxocarbenium Destabilization: While the Cl atom destabilizes the intermediate oxocarbenium ion (via inductive withdrawal), the use of strong Lewis acids (e.g., TMSOTf, Bi(OTf)) or ionizing solvents (e.g., HFIP) drives the equilibrium toward cyclization.

Reaction Pathway

The reaction proceeds via a cascade sequence:

- Activation: The Lewis Acid (LA) activates the ketone carbonyl.
- Hemiacetal Formation: The hydroxyl group of 2-phenylethanol attacks the activated carbonyl. [1]
- Oxocarbenium Generation: Elimination of water (or silanol if TMS-based) generates a reactive oxocarbenium ion.[1]
- Friedel-Crafts Cyclization: The tethered aromatic ring attacks the oxocarbenium ion, closing the pyran ring.
- Re-aromatization: Loss of a proton yields the 1-(chloromethyl)isochroman.[1]

Mechanistic Visualization

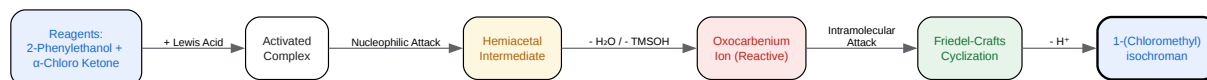

[Click to download full resolution via product page](#)

Figure 1: Mechanistic pathway of the acid-catalyzed condensation of

-chloro ketones with 2-phenylethanol.

Experimental Protocol

Reagents & Equipment

- Substrate A: 2-Phenylethanol (1.0 equiv)[1]
- Substrate B:
 - Chloro ketone (e.g., Chloroacetone, 2-Chloroacetophenone) (1.2 – 1.5 equiv)[1]
- Catalyst: Trimethylsilyl trifluoromethanesulfonate (TMSOTf) or Bismuth(III) triflate (Bi(OTf))
- Solvent: Dichloromethane (DCM, anhydrous) or Hexafluoroisopropanol (HFIP)
- Apparatus: Flame-dried round-bottom flask, inert atmosphere (or Ar).

Standard Operating Procedure (SOP)

Step 1: Reaction Setup

- Charge a flame-dried reaction vial with 2-phenylethanol (1.0 mmol, 122 mg) and the -chloro ketone (1.2 mmol).
- Dissolve in anhydrous DCM (5.0 mL, 0.2 M). Note: For difficult substrates, use HFIP as solvent to enhance ionization.

- Cool the mixture to 0 °C in an ice bath.

Step 2: Catalyst Addition

- Add TMSOTf (0.1 mmol, 18 μ L, 10 mol%) dropwise via syringe.
 - Caution: TMSOTf is moisture-sensitive and fuming.^[1] Handle under inert gas.
- Stir at 0 °C for 15 minutes, then allow to warm to room temperature (23 °C).

Step 3: Monitoring & Quenching

- Monitor reaction progress by TLC (Hexane/EtOAc 4:1) or LC-MS.^[1] Reaction is typically complete within 1–4 hours.
- Quench by adding saturated aqueous NaHCO₃ (5 mL).
- Stir vigorously for 5 minutes until bubbling ceases.

Step 4: Workup & Purification^{[1][2]}

- Extract the aqueous layer with DCM (3 x 10 mL).
- Dry combined organics over anhydrous Na₂SO₄.
- Concentrate under reduced pressure.
- Purify via flash column chromatography (Silica gel, gradient 0-10% EtOAc in Hexanes).

Workflow Diagram

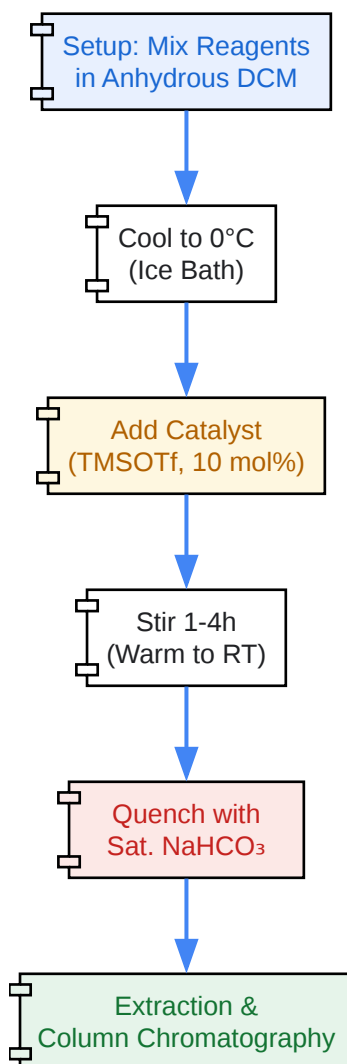

[Click to download full resolution via product page](#)

Figure 2: Step-by-step experimental workflow for the one-pot synthesis.[1]

Data Interpretation & Optimization

Catalyst Comparison

The choice of catalyst significantly impacts the yield, particularly for electron-deficient aromatic rings.

Catalyst	Loading	Conditions	Yield (%)	Notes
TMSOTf	10 mol%	DCM, 0°C to RT	85-92%	Best general performance; requires dry conditions.[1]
Bi(OTf)	5 mol%	DCM, RT	78-85%	Moisture tolerant; good for large scale.
TfOH	10 mol%	HFIP, RT	88-95%	Excellent for deactivated arenes; HFIP stabilizes the cation.
BF ·OEt	20 mol%	DCM, 0°C	60-70%	Lower yields; significant side reactions.[1]

Substrate Scope & Limitations

- Electron-Rich Arenes (e.g., 3,4-dimethoxy): React rapidly (<1 h). High yields.
- Electron-Neutral Arenes: Standard conditions apply (2-4 h).
- Electron-Poor Arenes (e.g., 4-nitro): Require HFIP as solvent and TfOH as catalyst to force cyclization.[1]
- -Chloro Ketone Sterics: Methyl ketones (chloroacetone) react faster than phenyl ketones (-chloroacetophenone).[1]

Troubleshooting Guide

Issue	Probable Cause	Corrective Action
Low Conversion	Wet solvent/catalyst	Ensure DCM is distilled/dried. [1] Use fresh TMSOTf.
Side Products	Polymerization of ketone	Add ketone slowly or lower temperature to -20°C initially. [1]
No Cyclization	Deactivated Arene	Switch solvent to HFIP (Hexafluoroisopropanol) to increase electrophilicity.
Hydrolysis of Product	Acidic workup	Ensure full neutralization with NaHCO before concentration.

References

- Gu, Q., et al. "Synthesis of functionalised isochromans: epoxides as aldehyde surrogates in hexafluoroisopropanol." *Chemical Science*, 2023.
 - Key Insight: Establishes the use of HFIP and triflates for difficult Oxa-Pictet-Spengler cycliz
- Organic Chemistry Portal. "Synthesis of Isochromans."
 - Key Insight: General methodologies and catalyst comparisons for isochroman synthesis.
- Larock, R. C. *Comprehensive Organic Transformations*. "Formation of Bonds to C, H, O, Halogens, N, S, and P." Wiley-VCH.
- Yadav, J. S., et al. "Bismuth(III) triflate catalyzed mild and efficient synthesis of isochromans." *Tetrahedron Letters*, 2002.

Need Custom Synthesis?

BenchChem offers custom synthesis for rare earth carbides and specific isotopic labeling.

Email: info@benchchem.com or [Request Quote Online](#).

Sources

- 1. CN1466561A - A method for preparing α ' chloro ketones - Google Patents [patents.google.com]
- 2. US6215006B1 - Process for the preparation of 3-isochromanones by cyclization of o-chloromethylphenylacetic acids - Google Patents [patents.google.com]
- To cite this document: BenchChem. [Application Note: One-Pot Synthesis of Isochromans from -Chloro Ketones]. BenchChem, [2026]. [Online PDF]. Available at: [<https://www.benchchem.com/product/b14049894/docs#application-note-one-pot-synthesis-of-isochromans-from-chloro-ketones>]

Disclaimer & Data Validity:

The information provided in this document is for Research Use Only (RUO) and is strictly not intended for diagnostic or therapeutic procedures. While BenchChem strives to provide accurate protocols, we make no warranties, express or implied, regarding the fitness of this product for every specific experimental setup.

Technical Support: The protocols provided are for reference purposes. Unsure if this reagent suits your experiment?

Need Industrial/Bulk Grade? [Request Custom Synthesis Quote](#)

BenchChem

Our mission is to be the trusted global source of essential and advanced chemicals, empowering scientists and researchers to drive progress in science and industry.

Contact

Address: 3281 E Guasti Rd

Ontario, CA 91761, United States

Phone: (601) 213-4426

Email: info@benchchem.com

Contact our Ph.D. Support Team for a compatibility check