

Visualizing with "Dye 937": Application Notes and Protocols

Author: BenchChem Technical Support Team. **Date:** April 2026

Compound of Interest

Compound Name: Dye 937
Cat. No.: B14042203

[Get Quote](#)

Note: A specific fluorescent dye named "**Dye 937**" could not be identified in publicly available resources. It is presumed to be a proprietary or internal designation. To provide a practical and accurate guide, these application notes are based on Alexa Fluor™ 594, a widely used red-fluorescent dye with similar spectral characteristics to dyes in this range. The principles and protocols described here are broadly applicable to other red-fluorescent dyes and can be adapted once the specific spectral properties of "**Dye 937**" are known.

Introduction to Alexa Fluor™ 594

Alexa Fluor™ 594 is a bright and photostable red-fluorescent dye commonly used in various fluorescence imaging applications, including immunofluorescence, fluorescence microscopy, and flow cytometry.[1][2][3] Its high quantum yield and resistance to photobleaching make it an excellent choice for detecting low-abundance targets and for experiments requiring longer exposure times.[1][3] Furthermore, its fluorescence is pH-insensitive over a broad range, ensuring stable signal in different cellular environments.[3][4]

Spectral Properties and Filter Selection

To effectively visualize Alexa Fluor™ 594, it is crucial to use a fluorescence microscope equipped with the appropriate optical filters. The filter set should be optimized to match the

excitation and emission spectra of the dye to maximize signal detection and minimize background noise.

Parameter	Wavelength (nm)	Notes
Excitation Maximum	590	Can be efficiently excited by 561 nm or 594 nm laser lines. [1][5]
Emission Maximum	617-618	Emits in the red region of the visible spectrum.[6]
Recommended Excitation Filter	~560/40 nm (e.g., AT560/40x)	A bandpass filter that selectively transmits light in the excitation range of the dye.[7]
Recommended Dichroic Mirror	~600 nm (e.g., AT600DC)	Reflects excitation light towards the sample and transmits emitted light towards the detector.[7]
Recommended Emission Filter	~635/60 nm (e.g., AT635/60m)	A bandpass filter that selectively transmits the emitted fluorescence while blocking stray excitation light. [7]

Note: The filter specifications provided are examples. Researchers should consult their microscope manufacturer or a filter supplier like Chroma or Semrock for the optimal filter set for their specific instrument.

Application: Immunofluorescence Staining

Immunofluorescence (IF) is a powerful technique to visualize the localization of specific proteins within cells. The following protocol outlines a general procedure for staining adherent cells using a primary antibody and an Alexa Fluor™ 594-conjugated secondary antibody.

Experimental Workflow for Immunofluorescence

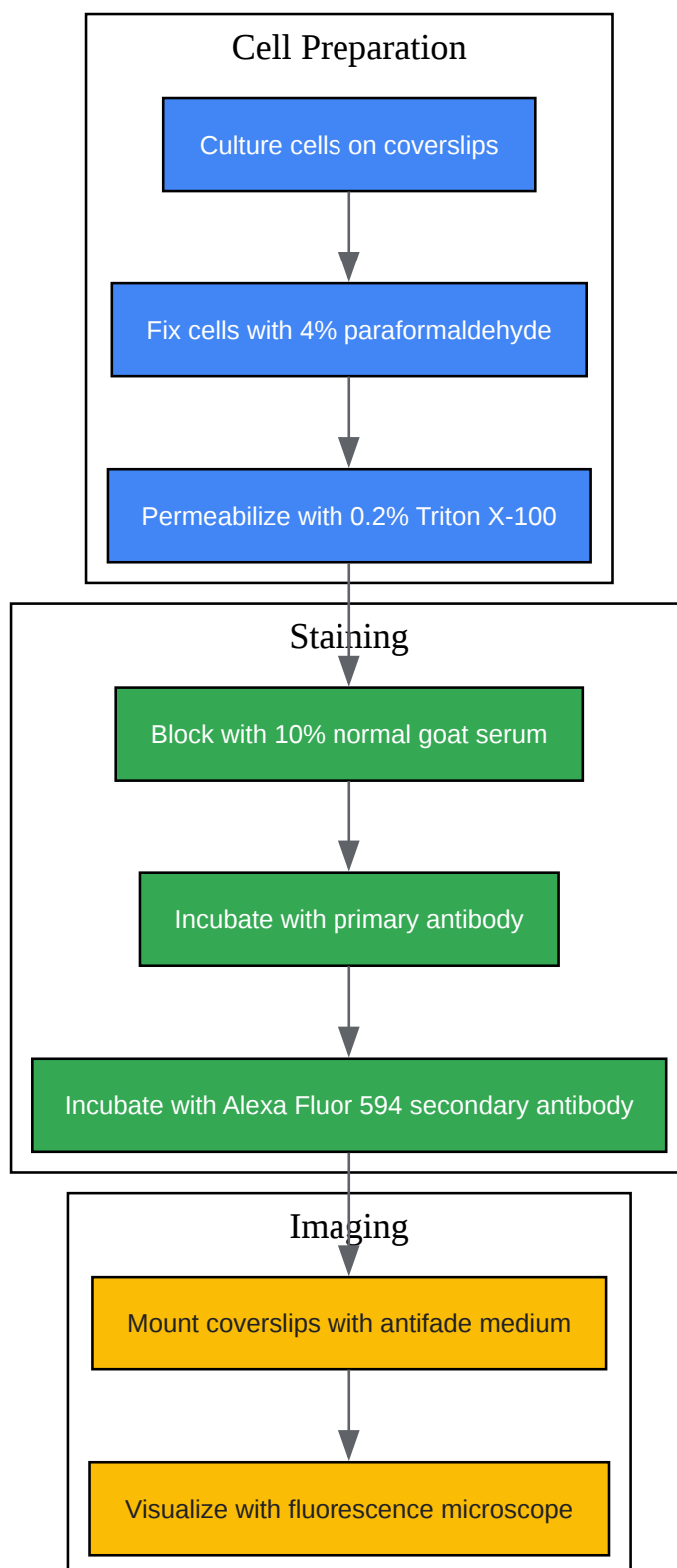

[Click to download full resolution via product page](#)

Figure 1. A generalized workflow for an immunofluorescence experiment.

Detailed Protocol for Immunofluorescence Staining of Adherent Cells

Materials:

- Phosphate-Buffered Saline (PBS)
- 4% Paraformaldehyde (PFA) in PBS
- 0.2% Triton™ X-100 in PBS
- Blocking Buffer (e.g., 10% normal goat serum in PBS)
- Primary antibody (specific to the target protein)
- Alexa Fluor™ 594-conjugated secondary antibody (e.g., Goat anti-Mouse IgG, Alexa Fluor™ 594)
- Antifade mounting medium with DAPI (for nuclear counterstain)
- Glass slides and coverslips

Procedure:

- Cell Culture: Grow adherent cells on sterile glass coverslips in a petri dish to the desired confluency.
- Fixation: Gently wash the cells with PBS. Fix the cells by incubating with 4% PFA in PBS for 15 minutes at room temperature.
- Washing: Wash the cells three times with PBS for 5 minutes each.
- Permeabilization: Incubate the cells with 0.2% Triton™ X-100 in PBS for 10 minutes at room temperature to permeabilize the cell membranes.[8]
- Washing: Wash the cells three times with PBS for 5 minutes each.

- **Blocking:** Block non-specific antibody binding by incubating the cells in Blocking Buffer for 1 hour at room temperature.[8]
- **Primary Antibody Incubation:** Dilute the primary antibody to its optimal concentration in the blocking buffer. Aspirate the blocking buffer from the coverslips and add the diluted primary antibody. Incubate overnight at 4°C in a humidified chamber.
- **Washing:** Wash the cells three times with PBS for 5 minutes each.
- **Secondary Antibody Incubation:** Dilute the Alexa Fluor™ 594-conjugated secondary antibody in the blocking buffer (a common dilution is 1:1000).[9] Incubate the cells with the diluted secondary antibody for 1 hour at room temperature, protected from light.
- **Washing:** Wash the cells three times with PBS for 5 minutes each, protected from light.
- **Mounting:** Mount the coverslips onto glass slides using a drop of antifade mounting medium containing DAPI.
- **Imaging:** Visualize the stained cells using a fluorescence microscope equipped with the appropriate filter sets for DAPI (blue) and Alexa Fluor™ 594 (red).

Visualizing Signaling Pathways: The MAPK/ERK Pathway

Immunofluorescence can be used to study the activation of signaling pathways. For example, the Mitogen-Activated Protein Kinase (MAPK)/Extracellular signal-Regulated Kinase (ERK) pathway is a crucial signaling cascade that regulates cell proliferation, differentiation, and survival.[10][11][12] A key event in this pathway is the phosphorylation of ERK, which can be detected by immunofluorescence using a phospho-specific ERK antibody.

MAPK/ERK Signaling Pathway Overview

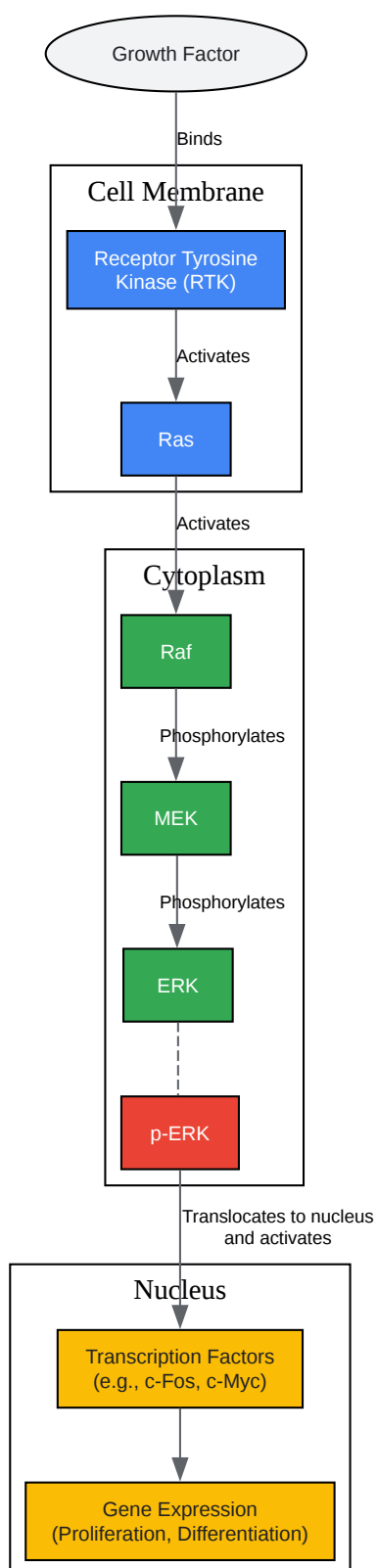

[Click to download full resolution via product page](#)

Figure 2. Simplified diagram of the MAPK/ERK signaling pathway.

By using a primary antibody that specifically recognizes the phosphorylated form of ERK (p-ERK) and an Alexa Fluor™ 594-conjugated secondary antibody, researchers can visualize the activation state of the MAPK/ERK pathway. An increase in red fluorescence would indicate an upregulation of this signaling cascade.

Need Custom Synthesis?

BenchChem offers custom synthesis for rare earth carbides and specific isotopic labeling.

Email: info@benchchem.com or [Request Quote Online](#).

References

- [1. Alexa Fluor 594 Dye | Thermo Fisher Scientific - HK \[thermofisher.com\]](#)
- [2. FluoroFinder \[app.fluorofinder.com\]](#)
- [3. Alexa dyes, a series of new fluorescent dyes that yield exceptionally bright, photostable conjugates - PubMed \[pubmed.ncbi.nlm.nih.gov\]](#)
- [4. Fluorophore Characteristics - Jackson Immuno \[jacksonimmuno.com\]](#)
- [5. Alexa Fluor 594 Dye | Thermo Fisher Scientific - SG \[thermofisher.com\]](#)
- [6. Spectrum \[Alexa Fluor 594\] | AAT Bioquest \[aatbio.com\]](#)
- [7. 39010-at-texas-red-mcherry-alexafluor-594 - Chroma Technology Corp \[chroma.com\]](#)
- [8. documents.thermofisher.com \[documents.thermofisher.com\]](#)
- [9. Immunofluorescence Protocol & Troubleshooting - Creative Biolabs \[creativebiolabs.net\]](#)
- [10. MAPK-ERK Signaling Pathway - Elabscience \[elabscience.com\]](#)
- [11. creative-diagnostics.com \[creative-diagnostics.com\]](#)
- [12. MAPK/ERK pathway - Wikipedia \[en.wikipedia.org\]](#)
- To cite this document: BenchChem. [Visualizing with "Dye 937": Application Notes and Protocols]. BenchChem, [2026]. [Online PDF]. Available at: [\[https://www.benchchem.com/product/b14042203/docs#visualizing-with-dye-937-application-notes-and-protocols\]](https://www.benchchem.com/product/b14042203/docs#visualizing-with-dye-937-application-notes-and-protocols)

Disclaimer & Data Validity:

The information provided in this document is for Research Use Only (RUO) and is strictly not intended for diagnostic or therapeutic procedures. While BenchChem strives to provide accurate protocols, we make no warranties, express or implied, regarding the fitness of this product for every specific experimental setup.

Technical Support: The protocols provided are for reference purposes. Unsure if this reagent suits your experiment?

Need Industrial/Bulk Grade? [Request Custom Synthesis Quote](#)

BenchChem

Our mission is to be the trusted global source of essential and advanced chemicals, empowering scientists and researchers to drive progress in science and industry.

Contact

Address: 3281 E Guasti Rd
Ontario, CA 91761, United States
Phone: (601) 213-4426
Email: info@benchchem.com

[Contact our Ph.D. Support Team for a compatibility check](#)