

Publish Comparison Guide: MALDI-TOF MS Verification of PEG16 Conjugation

Author: BenchChem Technical Support Team. **Date:** April 2026

Compound of Interest

Compound Name: N3-PEG16-Hydrzide

Cat. No.: B14033834

[Get Quote](#)

Executive Summary

In the precise landscape of bioconjugation, verifying the attachment of discrete polyethylene glycol (PEG) linkers—specifically PEG16—is a critical quality control gate. While PEGylation enhances solubility and pharmacokinetic profiles, the amphiphilic nature of PEG and its potential to suppress ionization presents analytical challenges.

This guide objectively compares MALDI-TOF MS against alternative verification methods (ESI-MS, SDS-PAGE), establishing it as the superior rapid-verification tool for discrete PEG16 conjugation.^[1] We provide a self-validating protocol designed to overcome the "ion suppression" effect often seen with PEGylated moieties.

Part 1: Comparative Analysis of Verification

Methods

For a researcher confirming the addition of a PEG16 linker (approx. 700–900 Da shift depending on functional groups), the choice of analytical method dictates the resolution and throughput of the data.

Table 1: Performance Matrix – MALDI-TOF vs. Alternatives[1]

Feature	MALDI-TOF MS	ESI-MS (LC-MS)	SDS-PAGE
Primary Output	Singly charged ions .[1] Clear mass shift ().	Multiple charge states . Complex deconvolution required.[1][2]	Migration distance (Apparent MW).
PEG16 Resolution	High. Discrete PEG16 shows a distinct mass shift.[1]	Variable. Charge state overlap can obscure the PEG signal if sample is heterogeneous.	Low. Cannot distinguish +1 vs +2 PEG additions accurately.
Sample Tolerance	High. Tolerates salts (<100 mM) and non-volatile buffers.	Low. Requires strict desalting/LC separation.[1]	High. Tolerates most buffers.[1]
Throughput	Rapid (<1 min/sample). Ideal for screening multiple reaction conditions.[1]	Slow (15–60 min/sample). Includes LC run time.	Slow (2–4 hours). Gel running and staining.
Data Interpretation	Straightforward. directly corresponds to linker mass.[1]	Complex. PEG polydispersity (if present) complicates charge envelopes.[1]	Qualitative. "Smear" or band shift only.

Verdict: While ESI-MS offers higher resolution for peptide mapping, MALDI-TOF is the superior choice for rapid, intact mass verification of PEG16 conjugation due to its generation of singly charged ions, which simplifies the detection of the specific mass addition.

Part 2: Deep Dive – MALDI-TOF Methodology for PEG16

The Chemistry of Ionization

PEG chains are polyethers that can wrap around metal cations (Na^+ , K^+). In MALDI, this often leads to signal splitting between protonated

and sodiated

species.

- The Challenge: PEG16 is relatively small (~750 Da). If the protein/peptide is small (<5 kDa), the matrix interference region can obscure the signal. If the protein is large (>20 kDa), the resolution in Linear mode may struggle to resolve a <1 kDa shift.
- The Solution:
 - For Peptides (<10 kDa): Use Reflectron Mode for isotopic resolution.
 - For Proteins (>10 kDa): Use Linear Mode with optimized detector gain.
 - Matrix Choice: DHB (2,5-Dihydroxybenzoic acid) is preferred over CHCA for PEGylated conjugates because it forms "softer" crystals that encourage ionization of the PEG moiety without extensive fragmentation [1].

Experimental Workflow Diagram

The following diagram outlines the critical decision pathways for verifying PEG16 conjugation.

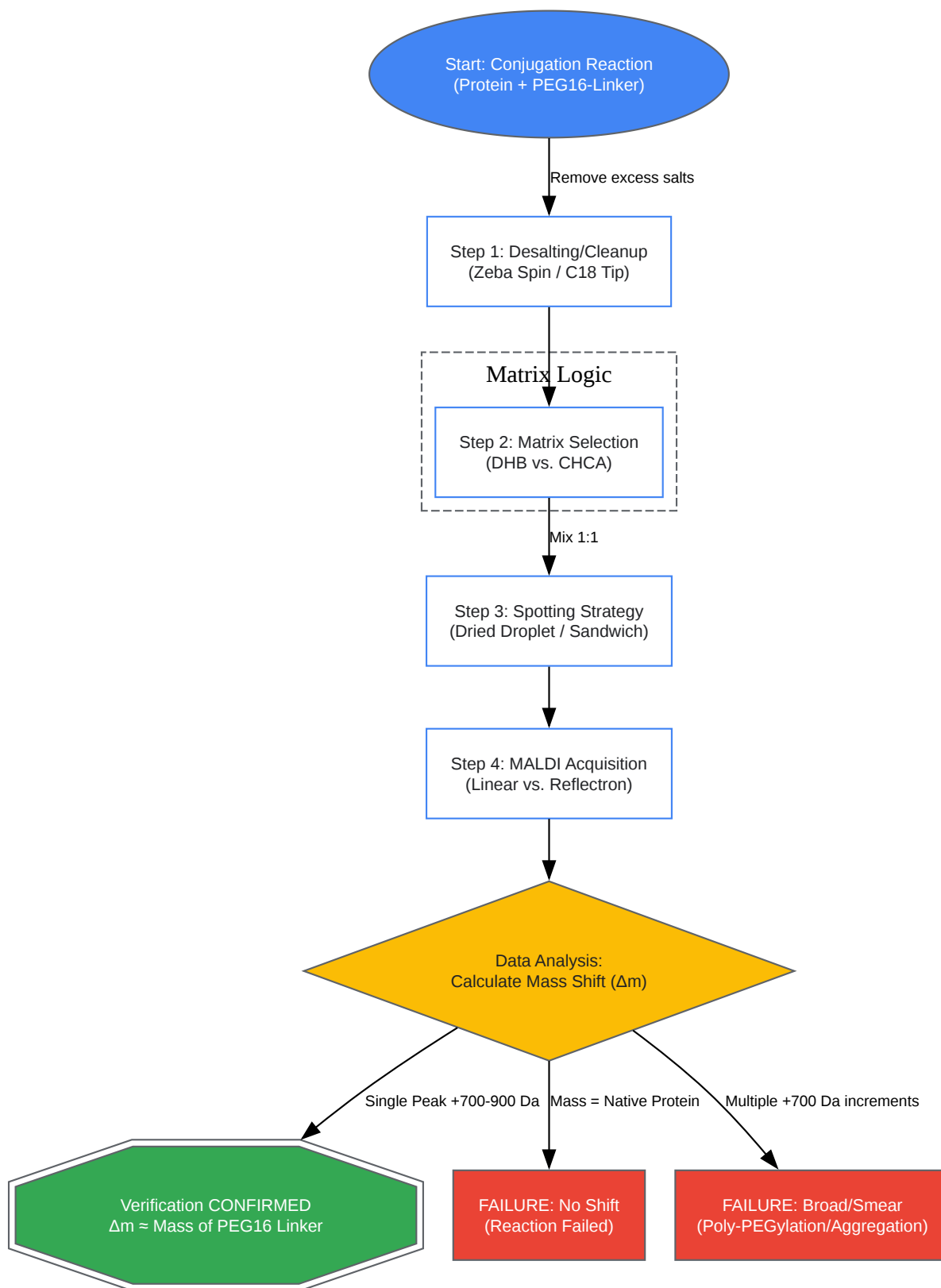

[Click to download full resolution via product page](#)

Figure 1: Decision-matrix workflow for MALDI-TOF verification of PEG16 conjugation, highlighting critical "Go/No-Go" checkpoints.

Part 3: Step-by-Step Verification Protocol

This protocol is self-validating: it includes internal checkpoints to ensure instrument performance is not mistaken for experimental failure.

Phase 1: Sample Preparation

Objective: Remove excess unreacted PEG16 reagents which can suppress protein ionization. [1]

- Desalting: Use a C18 ZipTip (for peptides) or a Zeba Spin Column (for proteins >10 kDa).
 - Why: High salt concentrations (>100 mM) form adduct clusters that mimic PEG mass shifts.[1]
- Concentration: Adjust final analyte concentration to ~1–10 pmol/μL.

Phase 2: Matrix Preparation (The DHB Advantage)

While CHCA is standard for peptides, DHB is superior for PEGylated samples due to its cooler crystallization, which preserves the labile PEG-protein bond [2].

- Reagent: 2,5-Dihydroxybenzoic acid (DHB).[1][3][4][5][6]
- Solvent: 50% Acetonitrile (ACN) / 0.1% Trifluoroacetic acid (TFA) in ddH₂O.
- Protocol:
 - Prepare 20 mg/mL DHB in the solvent.
 - Crucial Step: Vortex for 1 minute to fully dissolve.
 - Mix: Combine 1 μL Sample + 1 μL Matrix in a microtube (do not mix on target).

Phase 3: Acquisition & Analysis

- Spotting: Deposit 1 μL of the mixture onto a steel target plate. Allow to air dry at room temperature.^[1]
 - Visual Check: DHB should form a rim of needle-like crystals.^[1] Shoot the rim of the spot, not the center, for highest sensitivity ^[3].
- Instrument Settings:
 - Mode: Linear Positive (for proteins >10 kDa) or Reflectron Positive (for peptides <10 kDa).
 - Laser Power: Start low (30%) and increase in 2% increments. PEGylated samples often require slightly higher fluence than native proteins.^[1]
- Validation Calculation (The "Delta Check"): Calculate the theoretical mass addition.
 - Example: For a Maleimide-PEG16-NHS linker conjugating to a Lysine:
 - PEG16 backbone
Da.^[1]
 - Linker heads
Da.^[1]
 - Expected Shift:
Da.^[1]
 - Criterion: The observed peak must be shifted by this amount

(Linear) or

(Reflectron).

Part 4: Troubleshooting & Logic Pathway

Common failure modes in PEG16 verification and their spectral signatures.

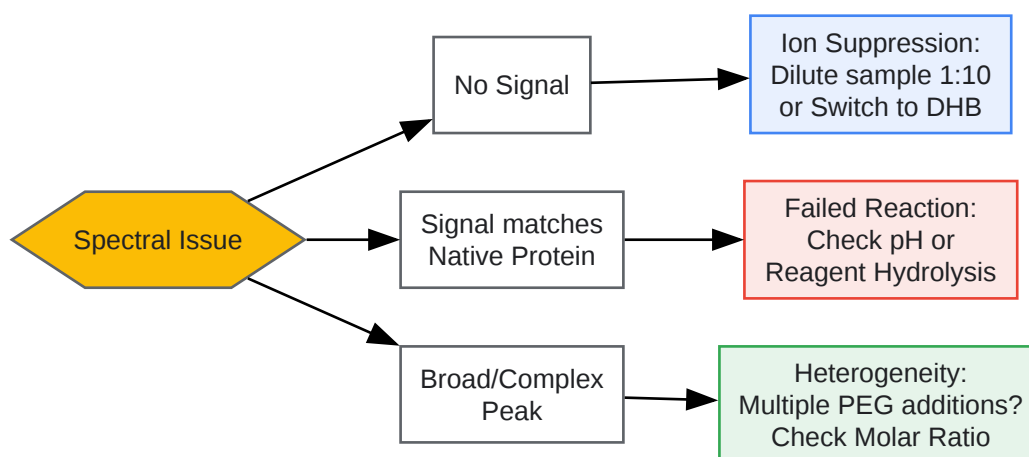

[Click to download full resolution via product page](#)

Figure 2: Troubleshooting logic for interpreting MALDI spectra of PEGylated conjugates.

Key Troubleshooting Insights

- The "Invisible" PEG: If you see the native protein but no conjugate, the PEG reagent may have hydrolyzed before conjugation. PEG-NHS esters are moisture-sensitive.[1] Always use fresh reagent.[1]
- Sodium Adducts: You may see a "satellite" peak +22 Da from your main peak.[1] This is a Sodium adduct (). Do not confuse this with a failed conjugation.

References

- Schiller, J. et al. (2007).[4] "Matrix-assisted laser desorption and ionization time-of-flight (MALDI-TOF) mass spectrometry in lipid and phospholipid research." European Biophysics Journal.[1][4]
- Bruker Daltonics. (2012). "MALDI-TOF Mass Spectrometry of Synthetic Polymers." Bruker Application Note.
- Signor, L. & Boeri Erba, E. (2013). "Matrix-assisted laser desorption/ionization time of flight (MALDI-TOF) mass spectrometric analysis of intact proteins larger than 100 kDa." Journal of Visualized Experiments.

- BroadPharm. "PEG16 Product Specifications and Molecular Weight." BroadPharm Catalog.

Need Custom Synthesis?

BenchChem offers custom synthesis for rare earth carbides and specific isotopic labeling.

Email: info@benchchem.com or [Request Quote Online](#).

Sources

- 1. [precisepeg.com](https://www.precisepeg.com) [[precisepeg.com](https://www.precisepeg.com)]
- 2. [researchgate.net](https://www.researchgate.net) [[researchgate.net](https://www.researchgate.net)]
- 3. Sample preparation strategies in MALDI – MassTech [[apmaldi.com](https://www.apmaldi.com)]
- 4. [covachem.com](https://www.covachem.com) [[covachem.com](https://www.covachem.com)]
- 5. [researchgate.net](https://www.researchgate.net) [[researchgate.net](https://www.researchgate.net)]
- 6. [spectroscopyeurope.com](https://www.spectroscopyeurope.com) [[spectroscopyeurope.com](https://www.spectroscopyeurope.com)]
- To cite this document: BenchChem. [Publish Comparison Guide: MALDI-TOF MS Verification of PEG16 Conjugation]. BenchChem, [2026]. [Online PDF]. Available at: [<https://www.benchchem.com/product/b14033834/docs#publish-comparison-guide-maldi-tof-ms-verification-of-peg16-conjugation>]

Disclaimer & Data Validity:

The information provided in this document is for Research Use Only (RUO) and is strictly not intended for diagnostic or therapeutic procedures. While BenchChem strives to provide accurate protocols, we make no warranties, express or implied, regarding the fitness of this product for every specific experimental setup.

Technical Support: The protocols provided are for reference purposes. Unsure if this reagent suits your experiment?

Need Industrial/Bulk Grade? [Request Custom Synthesis Quote](#)

BenchChem

Our mission is to be the trusted global source of essential and advanced chemicals, empowering scientists and researchers to drive progress in science and industry.

Contact

Address: 3281 E Guasti Rd

Ontario, CA 91761, United States

Phone: (601) 213-4426

Email: info@benchchem.com

[Contact our Ph.D. Support Team for a compatibility check](#)