

Preventing dimerization of 2,6-Dichloro-3H-indol-3-one

Author: BenchChem Technical Support Team. **Date:** May 2026

Compound of Interest

Compound Name: 2,6-Dichloro-3H-indol-3-one

Cat. No.: B14031376

[Get Quote](#)

Technical Support Center: 2,6-Dichloro-3H-indol-3-one

Welcome to the dedicated technical support guide for handling **2,6-Dichloro-3H-indol-3-one**. This resource is designed for researchers, chemists, and drug development professionals who utilize this highly reactive intermediate. My goal is to provide you with not just protocols, but the underlying chemical principles and field-proven insights to help you anticipate and overcome challenges, particularly the prevalent issue of dimerization.

Understanding the Core Challenge: The Inherent Reactivity of 2,6-Dichloro-3H-indol-3-one

2,6-Dichloro-3H-indol-3-one (also known as 2,6-dichloroindoxyl) is a powerful synthetic intermediate. However, its utility is matched by its instability. The core challenge stems from its high propensity to undergo self-condensation or dimerization. This occurs because the molecule possesses both nucleophilic and electrophilic character, making it highly reactive with itself, especially under unfavorable conditions.

The dimerization process is analogous to the final steps of indigo dye synthesis, where two indoxyl molecules couple to form the stable, colored dimer.^{[1][2][3]} One molecule of **2,6-dichloro-3H-indol-3-one** can act as an electrophile at its C2 position, while another, particularly its enolate tautomer, acts as a nucleophile. This rapid reaction leads to the formation of a highly conjugated, often insoluble, dimeric byproduct, significantly reducing the yield of your desired product.

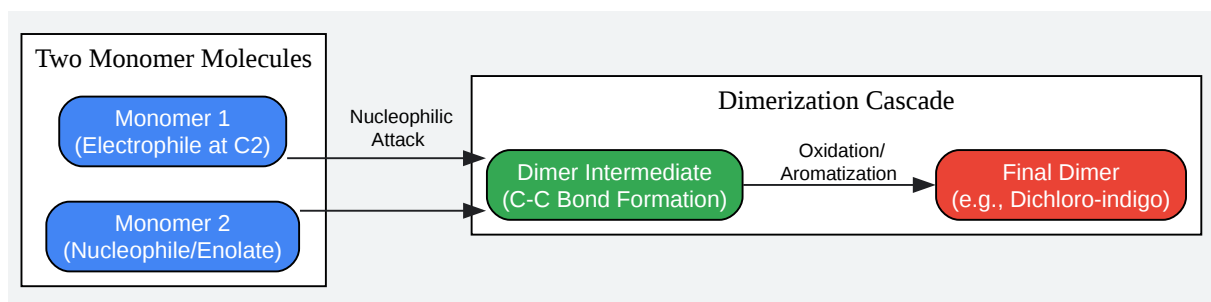

[Click to download full resolution via product page](#)

Caption: Proposed dimerization pathway of **2,6-Dichloro-3H-indol-3-one**.

Troubleshooting Guide: Dimerization and Side Reactions

This table addresses common problems encountered during reactions involving **2,6-Dichloro-3H-indol-3-one**. The solutions are based on controlling the kinetics and thermodynamics of the reaction environment.

Observed Problem	Probable Cause(s)	Recommended Solution & Preventative Measures
Rapid formation of a dark blue, purple, or green insoluble precipitate.	Dimerization and/or Oxidation: This is the classic sign of 2,6-Dichloro-3H-indol-3-one self-condensation to form an indigo-like dimer. The color is due to the extended π -conjugation in the dimer.	1. In Situ Generation & Immediate Trapping: Do not attempt to isolate the intermediate. Generate it in the presence of, or immediately add, your desired nucleophile or reactant. ^{[4][5]} 2. Reduce Temperature: Perform the reaction at low temperatures (-78 °C to 0 °C) to drastically slow the rate of the bimolecular dimerization reaction.3. Use Dilute Conditions: Lowering the concentration of the intermediate reduces the statistical probability of two molecules colliding.
Low or no yield of the desired product, with starting material consumed.	1. Dimerization Outcompetes Desired Reaction: The rate of dimerization is faster than the rate of your intended reaction.2. Degradation: The intermediate is unstable under the reaction conditions (e.g., pH, temperature, presence of oxygen).	1. Increase Nucleophile Equivalents: Use a larger excess of your trapping reagent to favor the desired bimolecular reaction.2. Optimize Order of Addition: Add the precursor of the indol-3-one slowly to a solution of the trapping nucleophile. This maintains a low instantaneous concentration of the reactive intermediate.3. Inert Atmosphere: Work under an inert atmosphere (Nitrogen or Argon) to prevent oxidative degradation pathways. Degas all solvents prior to use.

Reaction works, but yields are inconsistent.	Variable Stability of the Intermediate: Minor variations in reaction setup (moisture, air exposure, temperature fluctuations, solvent quality) significantly impact the lifetime of the reactive intermediate.[6]	1. Rigorous Control of Conditions: Ensure all glassware is oven-dried. Use anhydrous, degassed solvents. Maintain strict temperature control with a cryostat or a well-maintained cooling bath.2. Photostability: Indole derivatives can be light-sensitive.[7] Protect the reaction from light using amber glass flasks or by wrapping the flask in aluminum foil.
Complex mixture of byproducts observed by TLC or LC-MS.	1. Non-selective Reactivity: The intermediate is reacting with the solvent, impurities, or other species in the reaction mixture.2. pH-Catalyzed Degradation: Strongly acidic or basic conditions can catalyze both dimerization and other decomposition pathways.	1. Solvent Selection: Use aprotic, non-polar solvents (e.g., Toluene, Dichloromethane, THF) that are less likely to react with the intermediate. Avoid protic solvents like methanol unless it is the intended reactant.2. pH Control: Maintain a neutral or weakly acidic pH. If a base is required to generate the intermediate, use a non-nucleophilic, hindered base and add it slowly at low temperature.

Frequently Asked Questions (FAQs)

Q1: What is the most critical factor to control to prevent dimerization? A: Temperature. It is the most effective tool for controlling the reaction kinetics. By significantly lowering the temperature (e.g., to -78 °C using a dry ice/acetone bath), you dramatically reduce the rate of the dimerization, allowing your desired reaction (the "trapping" step) to proceed selectively.

Q2: Can I isolate and store **2,6-Dichloro-3H-indol-3-one** for later use? A: It is strongly discouraged. This compound is a highly reactive intermediate, not a stable, isolable product. Attempts to isolate and store it will almost certainly lead to extensive dimerization and degradation. The best practice is always in situ generation and immediate consumption in the subsequent reaction step.^{[4][5]}

Q3: Which class of solvents should I prioritize? A: Anhydrous, degassed, aprotic solvents are generally the best choice. Dichloromethane (DCM), tetrahydrofuran (THF), and toluene are common examples. Protic solvents like alcohols can potentially react with the intermediate or facilitate proton transfer steps that may lead to dimerization.

Q4: My synthesis requires a base. Which one should I use? A: If a base is necessary, for example, for a deprotonation step to form the intermediate, opt for a non-nucleophilic, sterically hindered base. Examples include lithium diisopropylamide (LDA) or lithium bis(trimethylsilyl)amide (LiHMDS). Always add the base slowly at very low temperatures to control the reaction and minimize side reactions.

Q5: How can I monitor the formation of the intermediate without it dimerizing? A: Monitoring is challenging due to the compound's instability. The most practical approach is to optimize the reaction based on the final, stable product. You can run small-scale test reactions and quench them at different time points after adding the precursor. Analysis of the quenched aliquots by LC-MS can help you understand the kinetics of formation and consumption. Direct monitoring via in-situ IR or NMR is possible but requires specialized equipment.

Experimental Protocol: A General Method for In Situ Generation and Nucleophilic Trapping

This protocol provides a generalized workflow for generating **2,6-Dichloro-3H-indol-3-one** and trapping it with a generic nucleophile (Nu-H). Note: This is a template; specific reagents, concentrations, and temperatures must be optimized for your particular system.

Objective: To perform a reaction with **2,6-Dichloro-3H-indol-3-one** while minimizing dimer formation.

Materials:

- Precursor to **2,6-Dichloro-3H-indol-3-one** (e.g., a suitable protected indole)
- Reagent for generation (e.g., N-Bromosuccinimide, then a mild base)
- Nucleophile (Nu-H, at least 2-3 equivalents)
- Anhydrous, degassed solvent (e.g., THF)
- Dry ice, acetone, and Dewar flask
- Standard inert atmosphere glassware setup (Schlenk line or balloon)

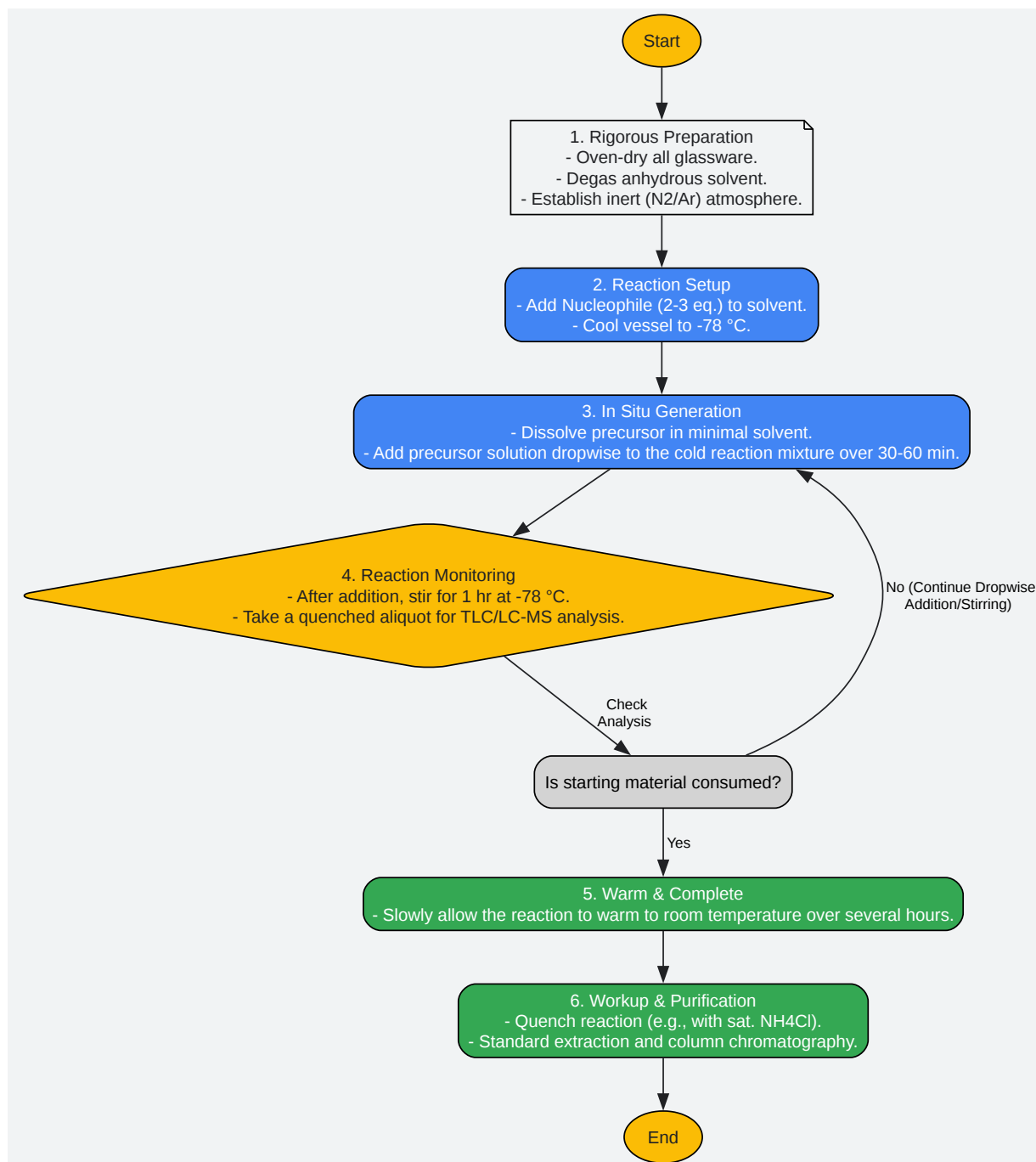

[Click to download full resolution via product page](#)

Caption: Decision workflow for handling the reactive intermediate.

Step-by-Step Methodology:

- Preparation: Assemble an oven-dried, three-neck round-bottom flask equipped with a magnetic stirrer, a thermometer, and a nitrogen/argon inlet.
- Initial Setup: Under a positive pressure of inert gas, charge the flask with your chosen anhydrous, degassed solvent and the nucleophile (2-3 equivalents).
- Cooling: Cool the reaction vessel to -78 °C using a dry ice/acetone bath. Ensure the solvent is at the target temperature before proceeding.
- Generation & Trapping: Dissolve the precursor of **2,6-Dichloro-3H-indol-3-one** (1 equivalent) in a minimal amount of the same anhydrous solvent. Using a syringe pump for controlled, slow addition, add the precursor solution dropwise to the cold, stirring solution of the nucleophile over a period of 30-60 minutes.
 - Causality Note: This slow addition is the most critical step. It ensures the instantaneous concentration of the highly reactive **2,6-Dichloro-3H-indol-3-one** is always extremely low. Any molecule of it that forms is statistically much more likely to encounter a molecule of the high-concentration nucleophile than another molecule of itself.
- Monitoring: After the addition is complete, allow the reaction to stir at -78 °C for an additional hour. At this point, you can take a small aliquot, quench it immediately in a separate vial with a suitable reagent (e.g., saturated ammonium chloride solution), and analyze it by TLC or LC-MS to check for the consumption of the starting material.
- Warming: Once the reaction is deemed complete at low temperature, slowly allow the mixture to warm to room temperature. This can be done by removing the cooling bath and letting it warm naturally.
- Workup and Purification: Quench the reaction appropriately (e.g., with water or saturated ammonium chloride). Perform a standard aqueous workup, extract the product with a suitable organic solvent, dry the organic layer, and purify by column chromatography.

References

- Sánchez-Viesca, F., Berros, M., & Gómez, R. (2016). On the Mechanism of the Baeyer-Drewsen Synthesis of Indigo. *American Journal of Chemistry*, 6(1), 18-22. [1][2][3]
- Stiasny, M. F., & Movassaghi, M. (2021). A general approach to 2,2-disubstituted indoxyls: total synthesis of brevianamide A and trigonoliimine C. *Chemical Science*, 12(40), 13756–13763. [4][5]
- Stournas, S., Barlos, K., & Johnson, B. (1993). Factors affecting the stability of fluorescent isoindoles derived from reaction of o-phthalaldehyde and hydroxyalkylthiols with primary amines. *Journal of Chromatography B: Biomedical Sciences and Applications*, 612(1), 45-51. [6]
- BenchChem. (n.d.). Stability studies of 6,7-dichloro-2,3-dihydro-1H-indole under different conditions. [7]
- Gyan Sanchay. (n.d.). Factors Affecting Stability. [8]

Need Custom Synthesis?

BenchChem offers custom synthesis for rare earth carbides and specific isotopic labeling.

Email: info@benchchem.com or [Request Quote Online](#).

Sources

- 1. [researchgate.net](https://www.researchgate.net) [researchgate.net]
- 2. [sapub.org](https://www.sapub.org) [sapub.org]
- 3. On the Mechanism of the Baeyer-Drewsen Synthesis of Indigo [article.sapub.org]
- 4. A general approach to 2,2-disubstituted indoxyls: total synthesis of brevianamide A and trigonoliimine C - PMC [pmc.ncbi.nlm.nih.gov]
- 5. [researchgate.net](https://www.researchgate.net) [researchgate.net]
- 6. Factors affecting the stability of fluorescent isoindoles derived from reaction of o-phthalaldehyde and hydroxyalkylthiols with primary amines - PubMed [pubmed.ncbi.nlm.nih.gov]
- 7. pdf.benchchem.com [pdf.benchchem.com]

- [8. gyansanchay.csjmu.ac.in](http://8.gyansanchay.csjmu.ac.in) [gyansanchay.csjmu.ac.in]
- To cite this document: BenchChem. [Preventing dimerization of 2,6-Dichloro-3H-indol-3-one]. BenchChem, [2026]. [Online PDF]. Available at: [<https://www.benchchem.com/product/b14031376/docs#preventing-dimerization-of-2-6-dichloro-3h-indol-3-one>]

Disclaimer & Data Validity:

The information provided in this document is for Research Use Only (RUO) and is strictly not intended for diagnostic or therapeutic procedures. While BenchChem strives to provide accurate protocols, we make no warranties, express or implied, regarding the fitness of this product for every specific experimental setup.

Technical Support: The protocols provided are for reference purposes. Unsure if this reagent suits your experiment?

Need Industrial/Bulk Grade? [Request Custom Synthesis Quote](#)

BenchChem

Our mission is to be the trusted global source of essential and advanced chemicals, empowering scientists and researchers to drive progress in science and industry.

Contact

Address: 3281 E Guasti Rd
Ontario, CA 91761, United States
Phone: (601) 213-4426
Email: info@benchchem.com

[Contact our Ph.D. Support Team for a compatibility check](#)